



# PRODUCT GUIDE

---

**BUILT  
STRONG**      **BACKED  
BY SERVICE**



U.S. Company Since 1998



## DEDICATION TO SERVICE

- MAGNA's experienced and knowledgeable team aims to respond to requests within minutes
- Offering same day shipping on orders received by 2 pm local time
- Long and custom length hoists ship the same or next day as ordered

## PREMIUM QUALITY AND DESIGN

- All hoist products load tested to 150% of rated capacity
- Designed for quick and inexpensive repairs
- 18% more robust design than the major competitors
- Lifetime warranty from manufacturer defects

## ABOUT MAGNA

**MAGNA Lifting Products** is a U.S. company that has been successfully providing the North American market with premium level lifting products for over 20 years.

MAGNA's lever, hand chain, and trolley products are manufactured in South Korea with all Korean steel and parts, which allows us to provide our customers with a durable, reliable product at an economical price.



# CONTENTS



02

## LEVER HOISTS

*CAPACITIES UP TO 15 TON*

Heavy duty rated design for vertical or horizontal lifting applications.

02



04

## HAND CHAIN HOISTS

*CAPACITIES UP TO 50 TON*

Heavy duty rated design for vertical lifting applications.

04

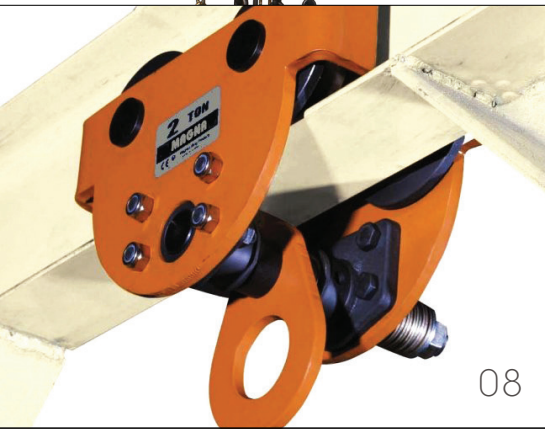

08

## TROLLEYS

*CAPACITIES UP TO 20 TON*

Heavy duty rated design available in geared and non-geared versions for operation on a wide range of beam sizes.

08

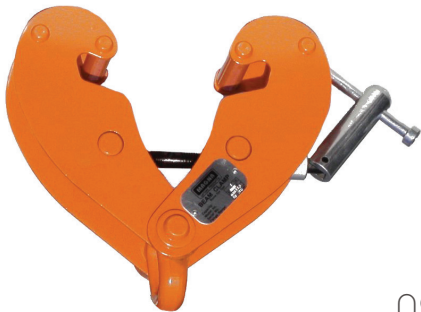

09

## BEAM CLAMPS

*CAPACITIES UP TO 10 TON*

Round-eye and pin-type versions available with adjustability to fit a wide range of beam sizes.

09



10

## WIRE ROPE PULLERS

*CAPACITIES UP TO 3 TON*

Compact and light weight design for use with any length wire rope.

10

# LEVER HOISTS

## PRODUCT DETAILS

- Manufactured in South Korea
- Completely repairable with easy access design
- Load tested to 150% of rated capacity
- Meets all applicable ANSI/ASME standards
- Single-hand control of free-chain function
- Weston Style Load Break
- Low temperature grease functions to -45°C (-49°F)

## STANDARD LENGTHS:

5', 10', 15', 20' *Long length and custom lengths available*

MODEL	LH025	LH075	LH100	LH150	LH150C	LH200	LH300	LH600	LH750	LH900	LH1200
SIZE (TONS)†	1/4	3/4	1	1 1/2	1 1/2	2	3	6	7 1/2	9	12
CAPACITY (LBS)	550	1,650	2,200	3,300	3,300	4,400	6,600	13,200	16,500	19,800	26,400
LOAD CHAIN (MM)	4.0 x 12.0	6.3 x 19.1	6.3 x 19.1	7.1 x 21.0	7.1 x 21.0	7.1 x 21.0*	9.0 x 27.0*	9.0 x 27.0*	9.0 x 27.0*	9.0 x 27.0*	9.0 x 27.0*
NET WEIGHT (LBS)**	4.5	15.6	16.3	22.0	21.0	23.0	36.1	60.6	92.5	106.0	119.0
MINIMUM LOAD (LBS)	66	66	66	99	99	99	198	396	496	595	794
PULL TO LIFT CAPACITY (LBS)	55	59	59	63	84	63	81	83	85	88	93
SIDE WIDTH A (IN)	3.90	6.18	6.18	6.89	6.89	6.89	7.80	7.80	7.80	7.80	7.80
WIDTH B (IN)	2.36	5.98	5.98	5.70	5.70	5.70	7.48	7.80	7.80	7.80	12.60
HEADROOM C (IN)	9.65	11.02	11.02	13.00	13.00	13.00	17.72	21.65	25.98	27.17	27.17
HANDLE LENGTH D (IN)	5.90	11.02	11.02	15.35	11.02	15.35	15.35	15.35	15.35	15.35	15.35
HOOK OPENING G (IN)	0.63	1.06	1.06	1.30	1.30	1.30	1.53	1.81	1.81	2.20	2.20

\*Grade 100 Chain \*\*With 5ft Lift †Metric ton rated

Note: "C" in part number stands for compact version

1/4 TON // LH025

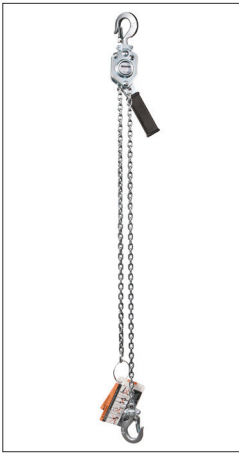

3/4 TON // LH075



1 TON // LH100



1 1/2 TON // LH150



1 1/2 TON COMPACT // LH150C



2 TON // LH200



3 TON // LH300



6 TON // LH600



7 1/2 TON // LH750

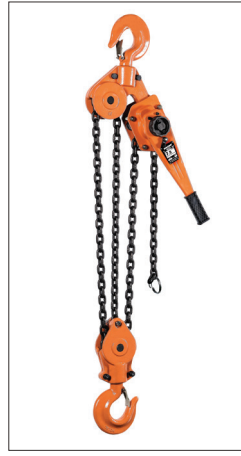

9 TON // LH900



12 TON // LH1200



UP TO 3 TONS

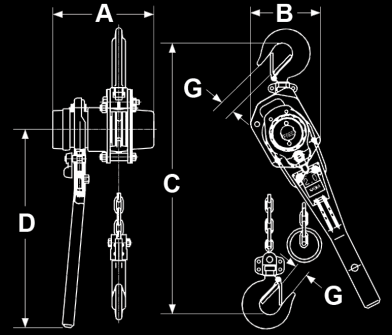

6 TONS

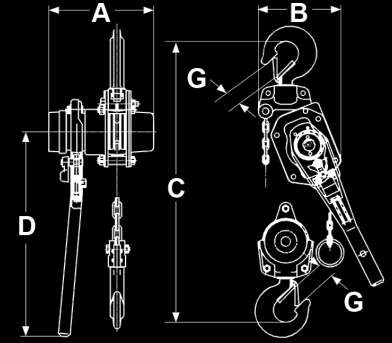

7.5 TONS AND ABOVE

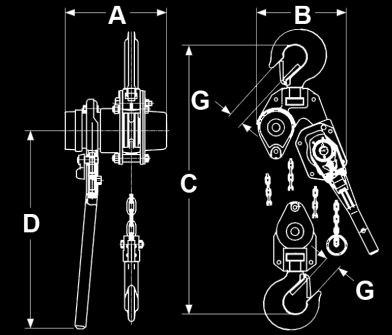

## ACCESSORIES

### OVERLOAD INDICATOR HANDLE

Handle will bend and show a red indicator when overloaded. Designed to be bent back to the original position and reused.

### SHIPYARD HOOK

Flat tipped hook to mitigate tip or point loading.

### SELF-LOCKING HOOK

Positive locking latch designed not to open during load.

### ELECTRO GALVANIZED CHAIN

Suitable to withstand corrosive environments.

# HAND CHAIN HOISTS

## PRODUCT DETAILS

- Manufactured in South Korea
- Completely repairable with easy access design
- Load tested to 150% of rated capacity
- Meets all applicable ANSI/ASME standards
- Low temperature grease functions to -45°C (-49°F)

## STANDARD LENGTHS:

10', 15', 20' *Long length and custom lengths available*

MODEL	CH050	CH100	CH150	CH200	CH300	CH300SF	CH500	CH750	CH1000	CH1500	CH2000
SIZE (TONS)†	1/2	1	1 1/2	2	3	3	5	7 1/2	10	15	20
CAPACITY (LBS)	1,100	2,200	3,300	4,400	6,600	6,600	11,000	16,500	22,000	33,000	44,000
LOAD CHAIN (MM)	6.3 x 19.1	6.3 x 19.1	7.1 x 21.0	7.9 x 23.0	7.1 x 21.0	9.0 x 27.0	9.0 x 27.0	9.0 x 27.0	9.0 x 27.0	9.0 x 27.0	9.0 x 27.0
HAND CHAIN (MM)	5.0 x 22.5	5.0 x 22.5	5.0 x 22.5	5.0 x 23.4	5.0 x 22.5	5.0 x 23.4	5.0 x 23.4	5.0 x 23.4	5.0 x 23.4	5.0 x 23.4	5.0 x 23.4
NET WEIGHT (LBS)*	25.0	26.0	31.0	43.0	49.0	57.0	86.0	119.0	152.0	317.0	403.0
NUMBER OF FALLS	1	1	1	1	2	1	2	3	4	6	8
HAND CHAIN OVERHAUL FOR 1 FT LIFT (FT)	40.3	40.3	54.4	84.3	108.8	93.5	187.0	285.4	374.0	285.4	374.0
PULL TO LIFT CAPACITY (LBS)	53	73	75	75	77	79	86	90	90	90x2**	90x2**
SIDE WIDTH A (IN)	5.79	5.79	5.79	7.05	5.79	7.05	7.05	7.05	7.05	8.15	8.15
WIDTH B (IN)	6.06	6.06	6.85	8.03	8.11	10.35	10.35	14.17	14.45	29.68	34.37
HEADROOM C (IN)	12.40	12.40	13.39	16.54	18.70	25.00	25.00	27.56	29.92	33.46	34.25
HOOK OPENING D (IN)	1.06	1.18	1.34	1.46	1.69	1.69	1.81	1.81	2.36	3.11	3.54

\*With 10 ft lift \*\*2 Hand Chain Falls †Metric ton rated



1/2 TON // CH050

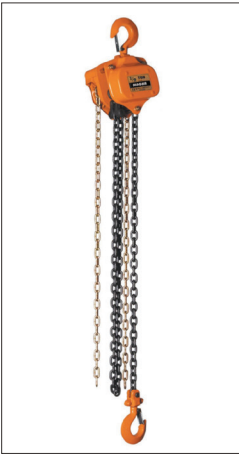

1 TON // CH100



1 1/2 TON // CH150

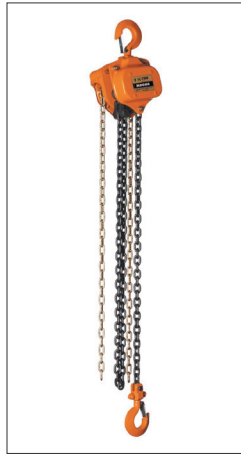

2 TON // CH200



3 TON // CH300



3 TON SINGLE FALL // CH300SF



5 TON // CH500



7 1/2 TON // CH750



10 TON // CH1000



15 TON // CH1500



20 TON // CH2000



UP TO 2 TONS AND 3 TON SF

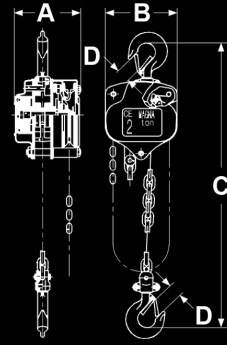

3 AND 5 TONS

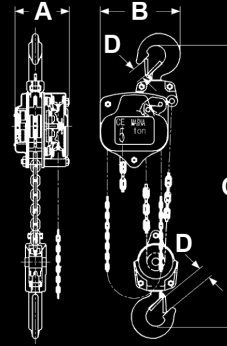

7.5 TONS AND ABOVE

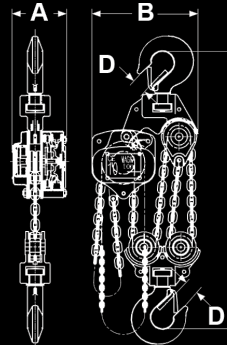

## ACCESSORIES

### OVERLOAD SLIP CLUTCH

Prevents the hoist from being used to lift loads beyond the rated capacity.

### SELF-LOCKING HOOK

Positive locking latch designed not to open under load.

### LUG MOUNT FOR LOW HEADROOM

Lug mounting to tuck the hoist up to the anchoring device and reduce total headroom.

### ELECTRO GALVANIZED CHAIN

Suitable to withstand corrosive environments.

### CHAIN BAG

Contains loose chain to protect equipment and increase safety.

# LEVER HOIST HIGHLIGHTS

Steel grip ring for **increased durability**

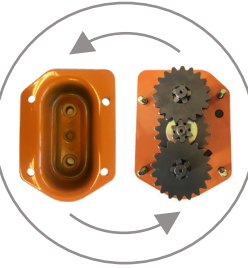

Central bushing that fixes the axis of rotation of the pinion shaft to create a **smoother and stronger overall operation**



Machined and case hardened ratchet gear with deep-cut teeth for **increased strength and durability**



Single-hand control of free-chain function for **easy and quick operation**

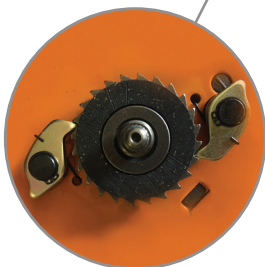

Two pawl gear engagement for **increased safety and power**



Long length rubber grip with stamped ribs to accommodate **diverse sizes** of hands and application environments



**Robust**, drop forged alloy steel hooks with wide throat openings for **durability and versatility**

## **SIMPLICITY**

Minimal number of parts to allow for simple and inexpensive repairs.

## **LOAD TESTING**

Load tested to 150% of rated capacity.



# CHAIN HOIST HIGHLIGHTS



Stamped steel casing for **reduced weight** and with high-strength hardware for **increased durability**



Considerably large brake surface area for **increased performance**

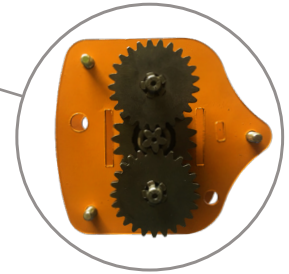

Machined and case hardened gears with deep-cut teeth for **increased strength and durability**



Spring and anchor system designed to facilitate easy hoist repairs and modifications



**Robust**, drop forged alloy steel hooks with wide throat openings for **durability and versatility**

## **SIMPLICITY**

Minimal number of parts to allow for simple and inexpensive repairs.

## **LOAD TESTING**

Load tested to 150% of rated capacity.

# TROLLEYS

## PRODUCT DETAILS

- Manufactured in South Korea
- Load tested to 150% of rated capacity
- Meets all applicable ANSI/ASME standards
- Anti-drop lugs included
- Sealed ball-bearing wheels

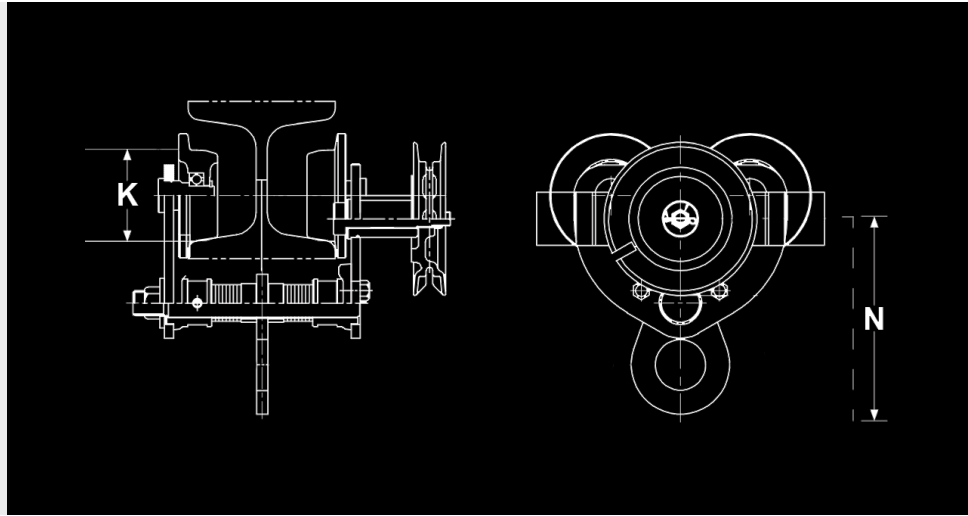

## PLAIN TROLLEY

MODEL	PTR050	PTR100	PTR200	PTR300	PTR500	PTR750*	PTR1000*
SIZE (TONS)†	1/2	1	2	3	5	7 1/2	10
CAPACITY (LBS)	1,100	2,200	4,400	6,600	11,000	16,500	22,000
FITS FLANGE WIDTH (IN)**	3-8	3-8	4-8	4-8	5-8	5-8	5-8
WHEEL TREAD DIA. K (IN)	2.17	3.16	3.94	4.45	4.82	4.82	4.82
MIN RADIUS CURVE (IN)	48	56	67	83	114	122	122
HEADROOM N (IN)	4.7	4.7	6.1	7.3	8.7	11.3	11.3
NET WEIGHT (LBS)	17	26	44	68	106	150	161



## GEARED TROLLEY

MODEL	GTR100	GTR200	GTR300	GTR500	GTR750*	GTR1000*
SIZE (TONS)†	1	2	3	5	7.5	10
CAPACITY (LBS)	2,200	4,400	6,600	11,000	16,500	22,000
FITS FLANGE WIDTH (IN)**	3-8	4-8	4-8	5-8	5-8	5-8
WHEEL TREAD DIA. K (IN)	3.16	3.94	4.45	4.82	4.82	4.82
MIN RADIUS CURVE (IN)	56	67	83	114	122	122
HEADROOM N (IN)	4.7	6.1	7.3	8.7	11.3	11.3
NET WEIGHT (LBS)	37	56	79	117	161	172



Standard hand chain drop length of 10'

\*Two pin design

\*\*Wider flange versions available

†Metric ton rated

# BEAM CLAMPS

## PRODUCT DETAILS

- Load tested to 125% of rated capacity
- Meets all applicable ANSI/ASME standards
- Easy installation and adjustable design
- Threaded screw locks in place for additional safety

### ROUND EYE

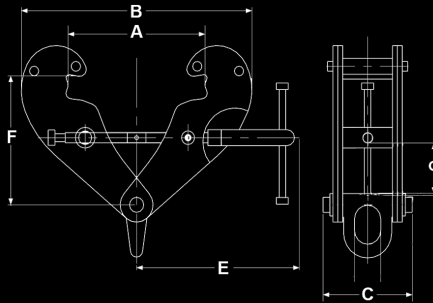

### PIN TYPE

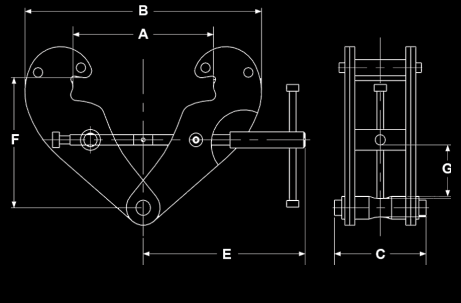

MODEL	PIN TYPE	BC100P	BC200P	BC300P	BC500P	BC1000P	
	ROUND EYE TYPE	BC100RE	BC200RE	BC300RE	BC500RE	BC1000RE	
SIZE (TONS)†		1	2	3	5	10	
RATED CAPACITY (LBS)		2,200	4,400	6,600	11,000	22,000	
I-BEAM WIDTH RANGE (IN)		3.1-9.7	3.1-9.7	3.5-13.0	3.5-13.0	3.5-13.4	
INCHES	A max	10.6	10.6	14.0	14.0	14.3	
	B	min	7.2	7.2	9.6	9.6	10.6
		max	14.6	14.6	19.7	19.7	20.5
	C	3.7	3.7	5.2	5.6	7.1	
	E	Pin Type	7.8	7.8	10.4	10.4	11.2
		Round Eye Type	8.6	8.6	10.9	10.9	11.9
	F	min	3.9	3.9	5.8	5.8	6.5
		max	6.1	6.1	8.6	8.3	9.4
	G	Pin Type	1.0	1.0	2.0	1.9	2.0
		Round Eye Type	1.7	1.7	2.4	2.4	3.6
NET WEIGHT (LBS)	Pin Type	8	8	21	24	35	
	Round Eye Type	9	11	22	26	37	



# WIRE ROPE PULLERS

## PRODUCT DETAILS

- Load tested to 125% of rated capacity
- Meets all applicable ANSI/ASME standards
- Can be operated in any position or direction

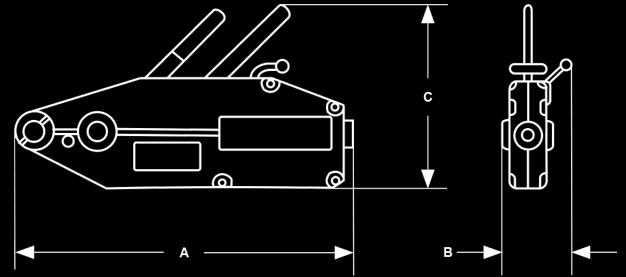

## ACCESSORIES

WIRE ROPE: Standard lengths of 33' and 65' (custom lengths available)

MODEL	WRP075C	WRP150C	WRP300C
SIZE (TONS)†	3/4	1 1/2	3
LIFTING CAPACITY (LBS)	1,760	3,525	7,050
ROPE ADVANCE PER FULL STROKE (IN)	2.0	2.2	1.1
ROPE DIAMETER (IN)	5/16	7/16	5/8
STANDARD WIRE ROPE LENGTH (FT)	33 & 65	33 & 65	33 & 65
NET WEIGHT (LBS) (W/HANDLE)	20	36	58
HANDLE LENGTH (IN)	32.5	47.5	47.5
PULLING EFFORT AT RATED CAPACITY (LBS)	64	93	99
A (IN)	17.0	21.5	26.0
B (IN)	2.5	3.8	4.5
C (IN)	9.0	10.3	12.5

†Metric ton rated



\* Wire rope not included standard, available per request

# OPTIONS & ACCESSORIES



## SHIPYARD HOOK

Flat tipped hook to mitigate tip or point loading

Available for lever hoists of 1 1/2 and 3 ton capacity



## SELF-LOCKING HOOK

Positive locking latch designed not to open under load

Available for lever hoist capacities of 3/4, 1, 1 1/2, and 3 ton and for hand chain hoist capacities of 1 1/2 ton



## OVERLOAD SLIP CLUTCH

Available for hand chain hoists to prevent the hoist from being used to lift loads beyond the rated capacity



## OVERLOAD INDICATOR HANDLE

For lever hoists to indicate an overloading beyond the rated capacity

Handle is designed to be snapped back into standard operating position and reused after load is reduced to below rated capacity



## LUG MOUNTING

Lug hoist mount for hand chain hoists to minimize total headroom

## CHAIN BAG

Nylon bag to hold loose chain, protect equipment, and increase safety

## ELECTRO GALVANIZED LOAD CHAIN

For applications which require a more corrosive resistant chain

## HIGH CAPACITY HOISTS AND TROLLEYS

Lever hoists, chain hoists, and trolleys available at capacities up to 50 ton



# CUSTOM HOISTS

## LONG LENGTH, CUSTOM LENGTH, AND HIGH CAPACITY



Custom length hoists, made per foot, readily available. *Includes load chain and hand chain.*

Long lift length hoists readily available. *No maximum length.*



Full range of high-capacity lever and chain hoists. *Hand chain hoists available up to 50 ton and lever hoists available up to 15 ton.*

12 TON // LH1200



20 TON // CH2000



**BUILT  
STRONG**

**BACKED  
BY SERVICE**

[www.magnalifting.com](http://www.magnalifting.com)

1140 Yew Ave.  
Blaine, WA 98231

Tel: 360.392.0432

Toll Free: 1.888.48.MAGNA

Fax: 360.464.2544

Email: [sales@magnalifting.com](mailto:sales@magnalifting.com)

V2. Rev. 00

