



# PEERLESS<sup>®</sup>

A KITO GROUP COMPANY

## Below-the-Hook & Material Handling Equipment



Visit Us Online:  
[www.peerlesschain.com](http://www.peerlesschain.com)  
800-873-1916



# PEERLESS<sup>®</sup>

A KITO GROUP COMPANY

With locations in Mount Pleasant, PA and South Holland, IL we are capable of satisfying all of your below-the-hook requirements from welded chain slings to motorized sheet lifters and much more.

Select products from our standard offering or we can design and manufacture a custom lifting device to fit your specific application from carbon, alloy, stainless, aluminum, or other specialty metals. Our experienced sales, engineering, and manufacturing staff are available to solve all of your below-the-hook lifting requirements.

- 100% of ALL Peerless lifting products are proof-tested.
- Horizontal proof test capabilities up to 1,200,000 lbs. & 40 feet in length.
- Vertical proof test capabilities up to 450,000 lbs.
- Certified to OSHA & ASME Standards.
- Capable of manufacturing to government & military specifications.
- Capable of bending up to 5" diameter round bar.
- We offer safety training & inspection services both in-house & on-site, including repairs & modifications.

## Table of Contents

### LIFTING EQUIPMENT

03 - 30	LIFTING BEAMS
31 - 42	SPREADER BEAMS
43 - 48	ROLL LIFTERS
49 - 59	COIL LIFTERS
60 - 64	TONGS
65 - 69	SHEET LIFTERS
71 - 79	PALLET LIFTERS
81 - 86	FORK TRUCK ACCESSORIES
87 - 91	MATERIAL HANDLING
92 - 95	SAFETY GUIDELINES
96 - 98	INDEX



[www.peerlesschain.com](http://www.peerlesschain.com)

**Our Website Contains a Full Line of Chain and Accessory Products Ready to View**

Browse our website to learn more about our company and products; download current literature and much more!

## SSLB

SHORT SPAN LIFTING BEAM  
PLATE STYLE ..... Page 4-5



## SDLB

STANDARD DUTY LIFTING BEAM  
CHANNEL DESIGN ..... Page 6-8



## SDLB

STANDARD DUTY LIFTING BEAM  
I-BEAM DESIGN w/FLAME CUT BAIL ..... Page 9-10



## SDLB

STANDARD DUTY LIFTING BEAM  
I-BEAM DESIGN w/PIN BAIL ..... Page 11



## BSLB

BASKET SLING LIFTING BEAM ..... Page 12-14



## DCLB

DUAL CRANE LIFTING BEAM ..... Page 15-16



## UNVB

UNIVERSAL LIFTING/SPREADER BEAM ..... Page 17



## ALB

ADJUSTABLE LIFTING BEAM ..... Page 18



## ABLB

ADJUSTABLE BAIL LIFTING BEAM ..... Page 19-21



## LLB

LOAD LEVELING BEAM ..... Page 22-23



## TPLB

THREE POINT LIFTING BEAM ..... Page 24



## FPLB

FOUR POINT LIFTING BEAM ..... Page 25



## FPSL

FOUR POINT SACK LIFTER BEAM ..... Page 26



## FPAB

FOUR POINT ADJUSTABLE BEAM ..... Page 27



## DCRB

DUAL CRANE ROTATING BEAM ..... Page 28



## CGCLB

CHLORINE GAS CYLINDER LIFTING BEAM ..... Page 29





## SHORT SPAN LIFTING BEAM PLATE STYLE

### FEATURES

- This style of lifting beam is ideal for short span applications and can be utilized where headroom is limited.
- Supplied with a pair of shackles and one standard spread.
- Engineered and manufactured to ASME B30.20 & BTH-1 Design Category B Service Class 2.
- 100% of ALL Peerless Lifting Beams are Proof-Tested to 125% capacity and certificates supplied at No Additional Charge.

### OPTIONS

- Additional lift points
- Higher capacities (supplied w/upper shackle)
- Additional lengths
- Upper shackle
- Upper shackle w/oblong link
- Hooks



**WARNING**

DO NOT EXCEED CAPACITY!  
See the SAFETY GUIDELINES section before using these products. Pages 92-95.

**Optional Design  
With Upper Shackle**

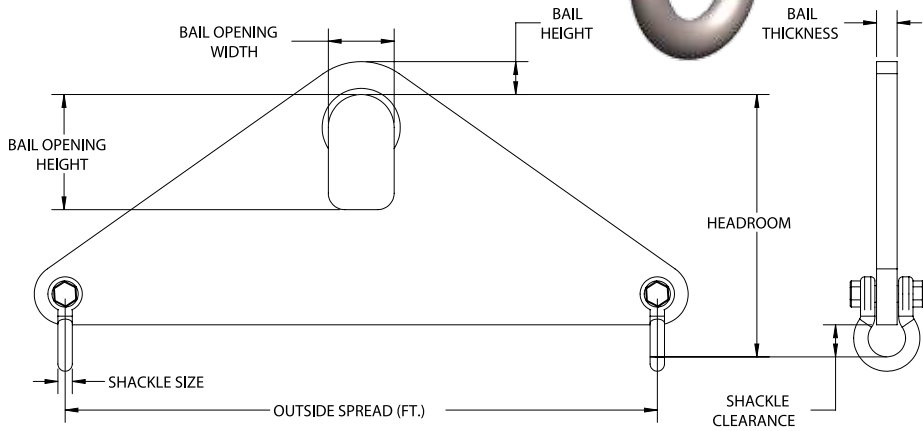
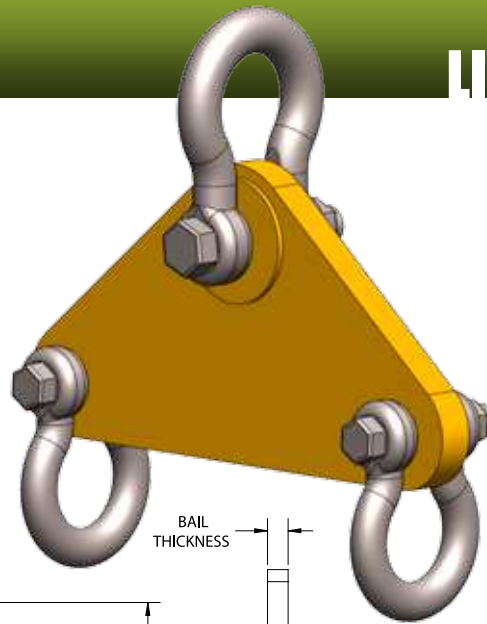

Model #	Capacity (US Tons)*	Outside Spread (Ft.)	Dimensions (Inches)							Weight (Lbs.)
			Headroom	Bail Height	Bail Opening Width	Bail Opening Height	Bail Thickness	Shackle Size	Shackle Clearance	
SSLB-.25-1	1/4	1	6.9	0.63	2	4	0.50	3/8	0.9	10
SSLB-.25-2	1/4	2	6.9	0.63	2	4	0.50	3/8	0.9	15
SSLB-.25-3	1/4	3	6.9	0.63	2	4	0.50	3/8	0.9	25
SSLB-1-1	1	1	9.6	0.88	3	5	0.75	5/8	1.6	20
SSLB-1-2	1	2	9.6	0.88	3	5	0.75	5/8	1.6	40
SSLB-1-3	1	3	9.6	0.88	3	5	0.75	5/8	1.6	50
SSLB-3-1	3	1	10.8	1.25	3	5	1	3/4	1.8	40
SSLB-3-2	3	2	10.8	1.25	3	5	1	3/4	1.8	60
SSLB-3-3	3	3	10.8	1.25	3	5	1	3/4	1.8	80
SSLB-10-2	10	2	16.1	2.00	4	7	1.25	7/8	2.1	110
SSLB-10-3	10	3	16.1	2.00	4	7	1.25	7/8	2.1	140
SSLB-20-2	20	2	20.1	2.50	5	9	1.50	1-1/4	3.1	160
SSLB-20-3	20	3	20.1	2.50	5	9	1.50	1-1/4	3.1	220
SSLB-40-2	40	2	29.5	3.50	7	16	2.50	1-3/4	4.5	420
SSLB-40-3	40	3	29.5	3.50	7	16	2.50	1-3/4	4.5	550
SSLB-50-2	50	2	31	3.63	7	16	2.50	1 3/4	4.5	440
SSLB-50-3	50	3	31	3.63	7	16	2.50	1 3/4	4.5	565
SSLB-70-2	70	2	34	4.00	7	18	3.00	2	4.8	620
SSLB-70-3	70	3	34	4.00	7	18	3.00	2	4.8	795
SSLB-110-2	110	2	40	5.25	8	20	3.50	2 1/2	7	960
SSLB-110-3	110	3	40	5.25	8	20	3.50	2 1/2	7	1200
SSLB-149-2	149	2	46	6.00	9	22	4.00	3	8.8	1050
SSLB-149-3	149	3	46	6.00	9	22	4.00	3	8.8	1350
SSLB-170-2	170	2	47.2	6.50	10	24	4.00	3	8.2	1150
SSLB-170-3	170	3	47.2	6.50	10	24	4.00	3	8.2	1450
SSLB-195-2	195	2	49.7	6.50	10	24	5.00	3 1/2	9.7	1780
SSLB-195-3	195	3	49.7	6.50	10	24	5.00	3 1/2	9.7	2100

\* 1 US Ton = 2,000 Lbs



**DO NOT EXCEED CAPACITY!**  
See the SAFETY GUIDELINES section before using these products. Pages 92-95.



## SDLB STANDARD DUTY LIFTING BEAM

CHANNEL DESIGN

### FEATURES

- This style of lifting beam can be utilized where headroom is limited and comes with a pair of swivel hooks and three standard spreads (3' and 4' beams have two standard spreads).
- Three standard lift points for load adjustment: outside lift point, middle lift point (outside less 1'), inside lift point (middle less 1').
- Engineered and manufactured to ASME B30.20 & BTH-1 Design Category B Service Class 2. ■ 100% of ALL Peerless Lifting Beams are Proof-Tested to 125% capacity and certificates supplied at No Additional Charge.

### OPTIONS

- Additional lift points
- Higher capacities
- Additional lengths
- Low headroom bail
- Additional hooks
- Shackle lugs
- Faspins
- Integrated beam stands

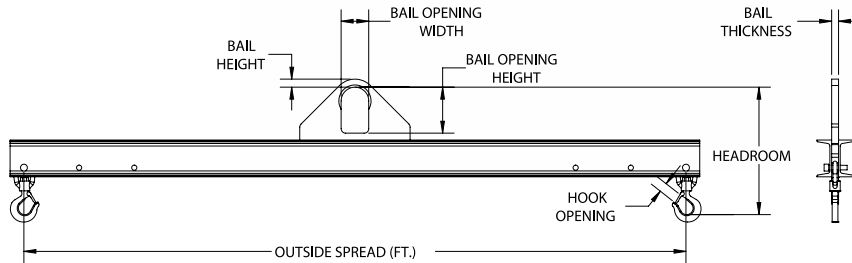
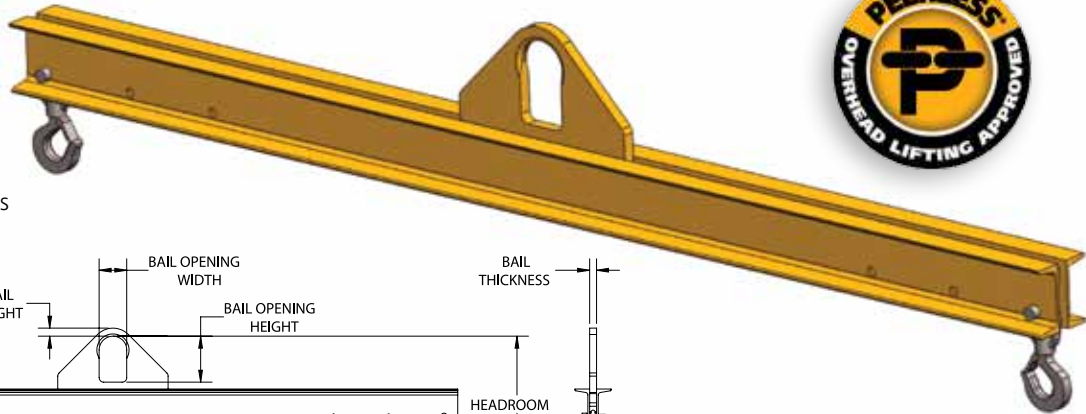

Model #	Capacity (US Tons)*	Outside Spread (Ft.)	Dimensions (Inches)						Weight (Lbs.)
			Headroom	Bail Height	Bail Opening Width	Bail Opening Height	Bail Thickness	Hook Opening	
SDLB-1/2-3	1/2	3	13	0.88	3	5	0.75	0.91	40
SDLB-1/2-4	1/2	4	13	0.88	3	5	0.75	0.91	50
SDLB-1/2-6	1/2	6	13	0.88	3	5	0.75	0.91	65
SDLB-1/2-8	1/2	8	13	0.88	3	5	0.75	0.91	80
SDLB-1/2-10	1/2	10	14	0.88	3	5	0.75	0.91	125
SDLB-1/2-12	1/2	12	14	0.88	3	5	0.75	0.91	145
SDLB-1/2-14	1/2	14	15	0.88	3	5	0.75	0.91	210
SDLB-1/2-16	1/2	16	16	0.88	3	5	0.75	0.91	360
SDLB-1/2-18	1/2	18	17	0.88	3	5	0.75	0.91	465
SDLB-1/2-20	1/2	20	18	0.88	3	5	0.75	0.91	490
SDLB-1/2-24	1/2	24	20	0.88	3	5	0.75	0.91	765
SDLB-1/2-30	1/2	30	22	0.88	3	5	0.75	0.91	1280
SDLB-1-3	1	3	13	0.88	3	5	0.75	0.91	40
SDLB-1-4	1	4	13	0.88	3	5	0.75	0.91	50
SDLB-1-6	1	6	14	0.88	3	5	0.75	0.91	80
SDLB-1-8	1	8	14	0.88	3	5	0.75	0.91	105
SDLB-1-10	1	10	15	0.88	3	5	0.75	0.91	150
SDLB-1-12	1	12	16	0.88	3	5	0.75	0.91	275
SDLB-1-14	1	14	17	0.88	3	5	0.75	0.91	365
SDLB-1-16	1	16	18	0.88	3	5	0.75	0.91	390
SDLB-1-18	1	18	19	0.88	3	5	0.75	0.91	505
SDLB-1-20	1	20	20	0.88	3	5	0.75	0.91	640
SDLB-1-24	1	24	22	0.88	3	5	0.75	0.91	1025

\* 1 US Ton = 2,000 Lbs

cont.



**DO NOT EXCEED CAPACITY!**  
See the SAFETY GUIDELINES section before using these products. Pages 92-95.

## STANDARD DUTY LIFTING BEAM - CHANNEL DESIGN cont.

Model #	Capacity (US Tons)*	Outside Spread (Ft.)	Dimensions (Inches)						Weight (Lbs.)
			Headroom	Bail Height	Bail Opening Width	Bail Opening Height	Bail Thickness	Hook Opening	
SDLB-2-3	2	3	13	0.88	3	5	0.75	0.91	40
SDLB-2-4	2	4	14	0.88	3	5	0.75	0.91	60
SDLB-2-6	2	6	15	0.88	3	5	0.75	0.91	95
SDLB-2-8	2	8	16	0.88	3	5	0.75	0.91	150
SDLB-2-10	2	10	17	0.88	3	5	0.75	0.91	265
SDLB-2-12	2	12	18	0.88	3	5	0.75	0.91	295
SDLB-2-14	2	14	19	0.88	3	5	0.75	0.91	400
SDLB-2-16	2	16	22	0.88	3	5	0.75	1.00	690
SDLB-2-18	2	18	22	0.88	3	5	0.75	1.00	775
SDLB-2-20	2	20	22	0.88	3	5	0.75	1.00	860
SDLB-2-24	2	24	25	0.88	3	5	0.75	1.00	1665
SDLB-3-3	3	3	14	1.25	3	5	1	1	55
SDLB-3-4	3	4	15	1.25	3	5	1	1	80
SDLB-3-6	3	6	16	1.25	3	5	1	1	155
SDLB-3-8	3	8	17	1.25	3	5	1	1	225
SDLB-3-10	3	10	18	1.25	3	5	1	1	260
SDLB-3-12	3	12	20	1.25	3	5	1	1	400
SDLB-3-14	3	14	22	1.25	3	5	1	1	620
SDLB-3-16	3	16	22	1.25	3	5	1	1	705
SDLB-3-18	3	18	26	1.25	3	5	1	1.36	1280
SDLB-3-20	3	20	26	1.25	3	5	1	1.36	1420
SDLB-3-24	3	24	26	1.25	3	5	1	1.36	1690
SDLB-5-3	5	3	18	2	4	7	1.25	1.36	100
SDLB-5-4	5	4	19	2	4	7	1.25	1.36	145
SDLB-5-6	5	6	20	2	4	7	1.25	1.36	210
SDLB-5-8	5	8	22	2	4	7	1.25	1.36	280
SDLB-5-10	5	10	24	2	4	7	1.25	1.36	380
SDLB-5-12	5	12	25	2	4	7	1.25	1.36	570
SDLB-5-14	5	14	30	2	4	7	1.25	1.61	1045
SDLB-5-16	5	16	30	2	4	7	1.25	1.61	1185
SDLB-5-18	5	18	30	2	4	7	1.25	1.61	1325
SDLB-5-20	5	20	30	2	4	7	1.25	1.61	1470
SDLB-5-24	5	24	33	2	4	7	1.25	1.61	2320
SDLB-7.5-3	7.5	3	21	2	4	7	1.25	1.61	130
SDLB-7.5-4	7.5	4	22	2	4	7	1.25	1.61	170
SDLB-7.5-6	7.5	6	24	2	4	7	1.25	1.61	235
SDLB-7.5-8	7.5	8	25	2	4	7	1.25	1.61	320
SDLB-7.5-10	7.5	10	27	2	4	7	1.25	1.61	495
SDLB-7.5-12	7.5	12	30	2	4	7	1.25	1.61	900
SDLB-7.5-14	7.5	14	30	2	4	7	1.25	1.61	1050
SDLB-7.5-16	7.5	16	30	2	4	7	1.25	1.61	1190
SDLB-7.5-18	7.5	18	33	2	4	7	1.25	1.61	1640
SDLB-10-3	10	3	22	2	4	7	1.25	1.61	145
SDLB-10-4	10	4	23	2	4	7	1.25	1.61	165
SDLB-10-6	10	6	25	2	4	7	1.25	1.61	260
SDLB-10-8	10	8	27	2	4	7	1.25	1.61	410
SDLB-10-10	10	10	30	2	4	7	1.25	1.61	770
SDLB-10-12	10	12	30	2	4	7	1.25	1.61	910
SDLB-10-14	10	14	30	2	4	7	1.25	1.61	1055
SDLB-10-16	10	16	33	2	4	7	1.25	1.61	1475
SDLB-10-18	10	18	33	2	4	7	1.25	1.61	1985

\* 1 US Ton = 2,000 Lbs

cont.



**DO NOT EXCEED CAPACITY!**  
See the SAFETY GUIDELINES section before using these products. Pages 92-95.



## SDLB

### STANDARD DUTY LIFTING BEAM cont. CHANNEL DESIGN

#### FEATURES

- This style of lifting beam can be utilized where headroom is limited and comes with a pair of swivel hooks and three standard spreads (3' and 4' beams have two standard spreads).
- Three standard lift points for load adjustment: outside lift point, middle lift point (outside less 1'), inside lift point (middle less 1').
- Engineered and manufactured to ASME B30.20 & BTH-1 Design Category B Service Class 2.
- 100% of ALL Peerless Lifting Beams are Proof-Tested to 125% capacity and certificates supplied at No Additional Charge.

#### OPTIONS

- Additional lift points
- Higher capacities
- Additional lengths
- Low headroom bail
- Additional hooks
- Shackle lugs
- Faspins
- Integrated beam stands

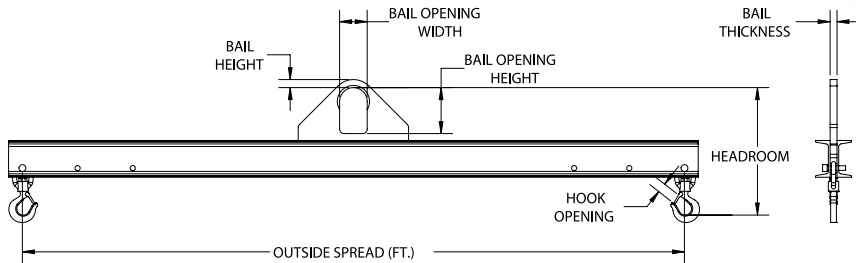
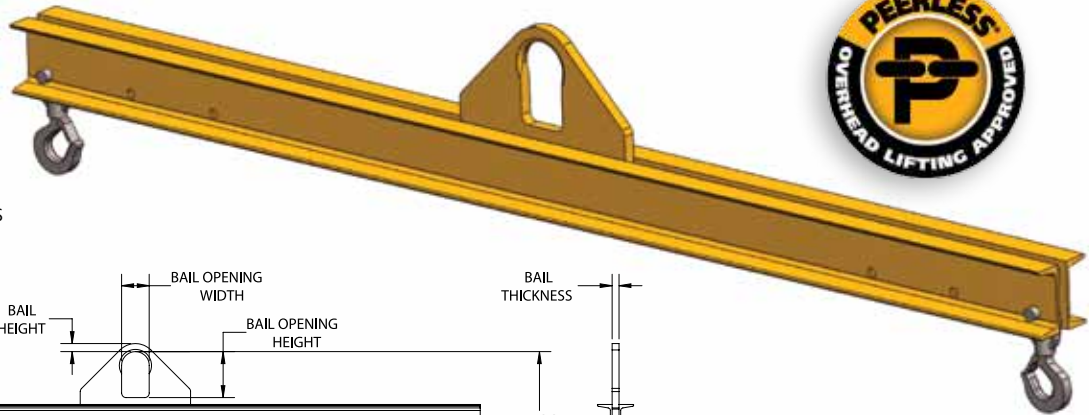

Model #	Capacity (US Tons)*	Outside Spread (Ft.)	Dimensions (Inches)						Weight (Lbs.)
			Headroom	Bail Height	Bail Opening Width	Bail Opening Height	Bail Thickness	Hook Opening	
SDLB-15-3	15	3	26	2.5	5	9	1.5	2.08	190
SDLB-15-4	15	4	28	2.5	5	9	1.5	2.08	255
SDLB-15-6	15	6	30	2.5	5	9	1.5	2.08	385
SDLB-15-8	15	8	33	2.5	5	9	1.5	2.08	700
SDLB-15-10	15	10	33	2.5	5	9	1.5	2.08	835
SDLB-15-12	15	12	37	2.5	5	9	1.5	2.08	1195
SDLB-15-14	15	14	37	2.5	5	9	1.5	2.08	1460
SDLB-20-3	20	3	29	2.5	5	9	1.5	2.27	235
SDLB-20-4	20	4	31	2.5	5	9	1.5	2.27	320
SDLB-20-6	20	6	34	2.5	5	9	1.5	2.27	575
SDLB-20-8	20	8	34	2.5	5	9	1.5	2.27	710
SDLB-20-10	20	10	35	2.5	5	9	1.5	2.27	840
SDLB-20-12	20	12	38	2.5	5	9	1.5	2.27	1585
SDLB-25-4	25	4	38	3	6	12	1.75	3.02	415
SDLB-25-6	25	6	41	3	6	12	1.75	3.02	680
SDLB-25-8	25	8	41	3	6	12	1.75	3.02	815
SDLB-25-10	25	10	44	3	6	12	1.75	3.02	1462
SDLB-25-12	25	12	44	3	6	12	1.75	3.02	1700
SDLB-30-4	30	4	45	3.5	7	16	2	3.02	655
SDLB-30-6	30	6	45	3.5	7	16	2	3.02	790
SDLB-30-8	30	8	48	3.5	7	16	2	3.02	1330
SDLB-40-4	40	4	45	3.5	7	16	2.5	3.02	745
SDLB-40-6	40	6	48	3.5	7	16	2.5	3.02	1185

\* 1 US Ton = 2,000 Lbs



**DO NOT EXCEED CAPACITY!**  
See the SAFETY GUIDELINES section before using these products. Pages 92-95.



## SDLB STANDARD DUTY LIFTING BEAM

I-BEAM DESIGN w/FLAME CUT BAIL

### FEATURES

- This style of lifting beam can be utilized where headroom is limited and comes with a pair of shackles & swivel hooks with three standard spreads.
- Standard I-Beam construction with integrated beam stands.
- Three standard lift points for load adjustment: outside lift point, middle lift point (outside less 1'), inside lift point (middle less 1').
- Engineered and manufactured to ASME B30.20 & BTH-1 Design Category B Service Class 2.
- 100% of ALL Peerless Lifting Beams are Proof Tested to 125% capacity and certificates supplied at No Additional Charge.

### OPTIONS

- Additional lift points
- Higher capacities
- Additional lengths
- Low headroom bail
- Additional hooks & shackles.

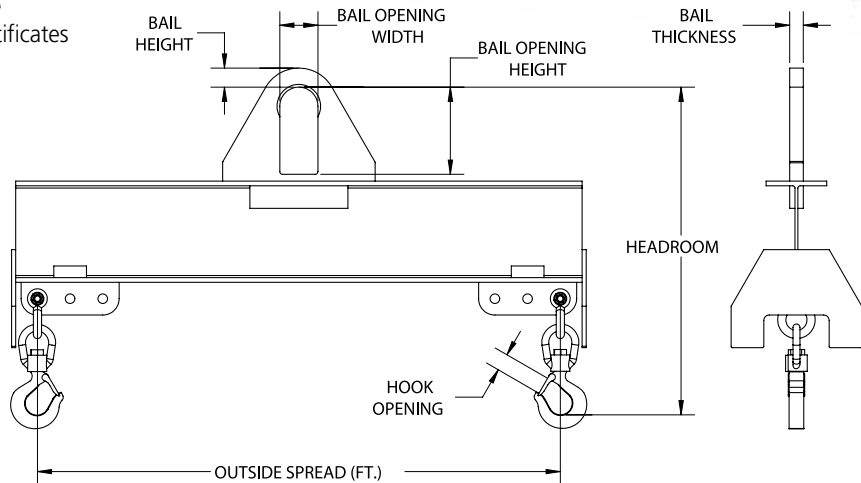
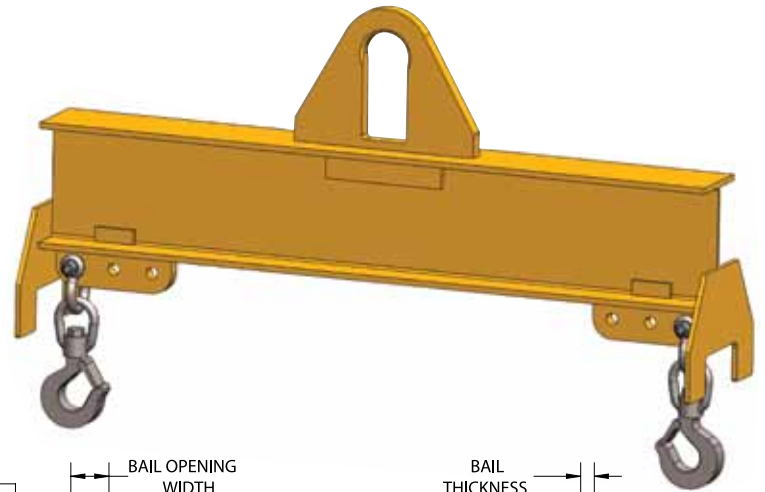

Model #	Capacity (US Tons)*	Outside Spread (Ft.)	Dimensions (Inches)						Weight (Lbs.)
			Headroom	Bail Height	Bail Opening Width	Bail Opening Height	Bail Thickness	Hook Opening	
SDLB-1-30	1	30	26	0.88	3	5	0.75	0.89	1575
SDLB-1-34	1	34	24	0.88	3	5	0.75	0.89	1685
SDLB-1-38	1	38	24	0.88	3	5	0.75	0.89	2225
SDLB-1-42	1	42	26	0.88	3	5	0.75	0.89	2950
SDLB-2-30	2	30	26	0.88	3	5	0.75	0.89	1680
SDLB-2-34	2	34	24	1.50	3	5	1	0.89	2240
SDLB-2-38	2	38	25	1.50	3	5	1	0.89	2820
SDLB-2-42	2	42	27	1.50	3	5	1	0.89	3580
SDLB-3-30	3	30	28	1.25	3	5	1	1	1995
SDLB-3-34	3	34	27	1.5	3	5	1	1	2175
SDLB-3-38	3	38	28	1.5	3	5	1	1	3270
SDLB-3-42	3	42	29	1.5	3	5	1	1	4085
SDLB-5-30	5	30	30	2	4	7	1.25	1.36	2430
SDLB-5-34	5	34	32	2	4	7	1.25	1.36	3290
SDLB-5-38	5	38	34	2	4	7	1.25	1.36	4150
SDLB-5-42	5	42	34	2	4	7	1.25	1.36	5000
SDLB-7.5-20	7.5	20	33	2	4	7	1.25	1.61	1390
SDLB-7.5-24	7.5	24	33	2	4	7	1.25	1.61	1985
SDLB-7.5-30	7.5	30	33	2	4	7	1.25	1.61	2900
SDLB-7.5-34	7.5	34	37	2	4	7	1.25	1.61	3740
SDLB-7.5-38	7.5	38	37	2	4	7	1.25	1.61	5000
SDLB-7.5-42	7.5	42	37	2	4	7	1.25	1.61	6020

\* 1 US Ton = 2,000 Lbs

cont.



**DO NOT EXCEED CAPACITY!**  
See the SAFETY GUIDELINES section before using these products. Pages 92-95.

# LIFTING EQUIPMENT

LIFTING BEAMS



## STANDARD DUTY LIFTING BEAM

I-BEAM DESIGN w/FLAME CUT BAIL cont.

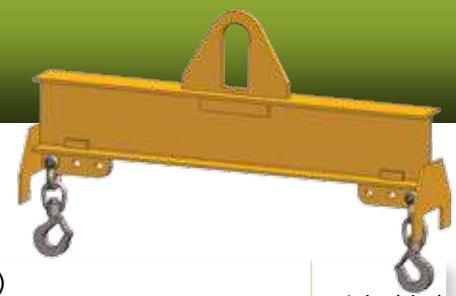

Model #	Capacity (US Tons)*	Outside Spread (Ft.)	Dimensions (Inches)						Weight (Lbs.)
			Headroom	Bail Height	Bail Opening Width	Bail Opening Height	Bail Thickness	Hook Opening	
SDLB-10-20	10	20	34	2	4	7	1.25	1.61	1540
SDLB-10-24	10	24	34	2	4	7	1.25	1.61	2180
SDLB-10-30	10	30	36	2	4	7	1.25	1.61	3310
SDLB-10-34	10	34	38	2	4	7	1.25	1.61	4515
SDLB-10-38	10	38	38	2	4	7	1.25	1.61	5495
SDLB-10-42	10	42	39	2	4	7	1.25	1.61	7260
SDLB-15-16	15	16	39	2.5	5	9	1.5	2.08	1430
SDLB-15-18	15	18	40	2.5	5	9	1.5	2.08	1690
SDLB-15-20	15	20	40	2.5	5	9	1.5	2.08	2015
SDLB-15-24	15	24	41	2.5	5	9	1.5	2.08	2825
SDLB-15-30	15	30	40	2.5	5	9	1.5	2.08	4470
SDLB-15-34	15	34	42	2.5	5	9	1.5	2.08	5400
SDLB-15-38	15	38	43	2.5	5	9	1.5	2.08	6655
SDLB-15-42	15	42	43	2.5	5	9	1.5	2.08	8840
SDLB-20-14	20	14	43	2.5	5	9	1.5	2.27	1270
SDLB-20-16	20	16	44	2.5	5	9	1.5	2.27	1590
SDLB-20-18	20	18	44	2.5	5	9	1.5	2.27	1980
SDLB-20-20	20	20	46	2.5	5	9	1.5	2.27	2340
SDLB-20-24	20	24	46	2.5	5	9	1.5	2.27	3315
SDLB-20-30	20	30	47	2.5	5	9	1.5	2.27	5295
SDLB-20-34	20	34	49	2.75	5	9	1.5	2.27	6565
SDLB-20-38	20	38	55	2.75	5	9	1.5	2.27	8580
SDLB-20-42	20	42	56	2.75	5	9	1.5	2.27	10430
SDLB-25-14	25	14	52	3	6	12	1.75	2.27	1620
SDLB-25-16	25	16	52	3	6	12	1.75	2.27	1995
SDLB-25-18	25	18	54	3	6	12	1.75	2.27	2345
SDLB-25-20	25	20	57	3	6	12	1.75	2.27	2865
SDLB-25-24	25	24	57	3	6	12	1.75	2.27	3870
SDLB-25-30	25	30	58	3	6	12	1.75	2.27	5810
SDLB-25-34	25	34	64	3	6	12	1.75	2.27	7800
SDLB-25-38	25	38	65	3	6	12	1.75	2.27	9555
SDLB-25-42	25	42	67	3	6	12	1.75	2.27	11800
SDLB-30-10	30	10	52	3.5	7	16	2	2.27	1210
SDLB-30-12	30	12	54	3.5	7	16	2	2.27	1465
SDLB-30-14	30	14	54	3.5	7	16	2	2.27	1780
SDLB-30-16	30	16	54	3.5	7	16	2	2.27	2155
SDLB-30-18	30	18	59	3.5	7	16	2	2.27	2500
SDLB-30-20	30	20	59	3.5	7	16	2	2.27	2995
SDLB-30-24	30	24	60	3.5	7	16	2	2.27	4240
SDLB-30-30	30	30	65	3.5	7	16	2	2.27	6015
SDLB-30-34	30	34	72	3.5	7	16	2	2.27	8330
SDLB-30-38	30	38	70	3.5	7	16	2	2.27	10605
SDLB-30-42	30	42	70	3.5	7	16	2	2.27	12915
SDLB-40-8	40	8	62	3.5	7	16	2.5	3.02	1260
SDLB-40-10	40	10	63	3.5	7	16	2.5	3.02	1630
SDLB-40-12	40	12	63	3.5	7	16	2.5	3.02	1935
SDLB-40-14	40	14	63	3.5	7	16	2.5	3.02	2335
SDLB-40-16	40	16	65	3.5	7	16	2.5	3.02	2520
SDLB-40-18	40	18	66	3.5	7	16	2.5	3.02	3255
SDLB-40-20	40	20	68	3.5	7	16	2.5	3.02	3865
SDLB-40-24	40	24	71	3.5	7	16	2.5	3.02	5170
SDLB-40-30	40	30	75	3.5	7	16	2.5	3.02	7155
SDLB-40-34	40	34	77	3.5	7	16	2.5	3.02	9780
SDLB-40-38	40	38	80	3.5	7	16	2.5	3.02	12075
SDLB-40-42	40	42	83	3.5	7	16	2.5	3.02	15240

\* 1 US Ton = 2,000 Lbs



**WARNING**

DO NOT EXCEED CAPACITY!  
See the SAFETY GUIDELINES section before using these products. Pages 92-95.

## SDLB STANDARD DUTY LIFTING BEAM

I-BEAM DESIGN w/PIN BAIL



### FEATURES

- This style of lifting beam can be utilized where headroom is limited & comes with a pair of shackles and three standard spreads.
- Standard I-Beam construction with pin bail & integrated beam stands.
- Three standard lift points for load adjustment: outside lift point, middle lift point (outside less 1'), inside lift point (middle less 1').
- Engineered & manufactured to ASME B30.20 & BTH-1 Design Category B Service Class 2.
- 100% of ALL Peerless Lifting Beams are Proof-Tested to 125% capacity & certificates supplied at No Additional Charge.

### OPTIONS

- Additional lift points
- Higher capacities
- Additional lengths
- Swivel hooks
- Additional shackles

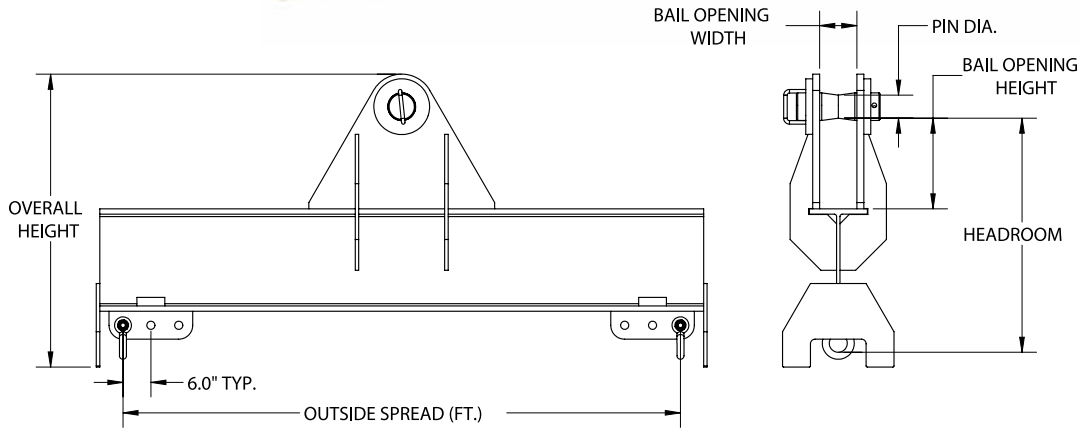
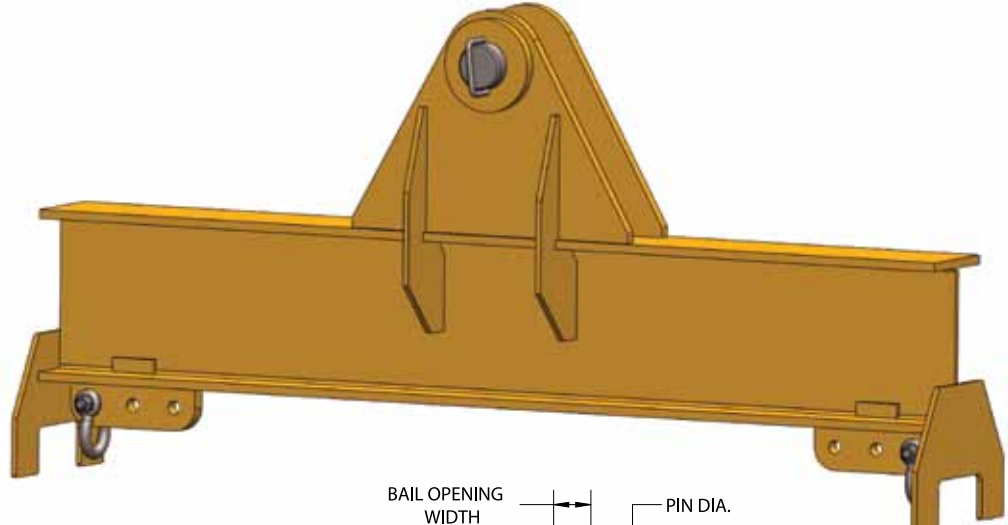

Model #	Capacity (US Tons)*	Outside Spread (Ft.)	Dimensions (Inches)					Overall Width	Overall Height	Weight (Lbs.)
			Headroom	Pin Diameter	Bail Opening Width	Bail Opening Height				
SDLB-50-10	50	10	57	5	8	19.5	138	70	3313	
SDLB-50-15	50	15	58	5	8	19.5	198	71	4417	
SDLB-50-20	50	20	58	5	8	19.5	258	71	5935	
SDLB-65-10	65	10	58	5	8	19.5	138	71	3518	
SDLB-65-15	65	15	61	5	8	19.5	198	74	4735	
SDLB-65-20	65	20	64	5	8	19.5	258	77	6671	
SDLB-80-10	80	10	64	5.5	8	21.25	138	77	4212	
SDLB-80-15	80	15	67	5.5	8	21.25	198	80	5529	
SDLB-80-20	80	20	70	5.5	8	21.25	258	83	7675	

\* 1 US Ton = 2,000 Lbs



**DO NOT EXCEED CAPACITY!**  
See the SAFETY GUIDELINES section before using these products. Pages 92-95.



## BASKET SLING LIFTING BEAM



### FEATURES

- This style of lifting beam can be utilized where headroom is limited with slings in a basket hitch.
- Includes two sets of fixed hooks (3' and 4' beams have one set of hooks).
- Two standard lift points for load adjustment; outside lift point & inside lift point (1/2 the overall length).
- Engineered & manufactured to ASME B30.20 & BTH-1 Design Category B Service Class 2.
- 100% of ALL Peerless Lifting Beams are Proof-Tested to 125% capacity & certificates supplied at No Additional Charge.

### OPTIONS

- Additional lift points
- Higher capacities
- Additional lengths
- Low headroom bail
- Additional hooks
- Sling spacers

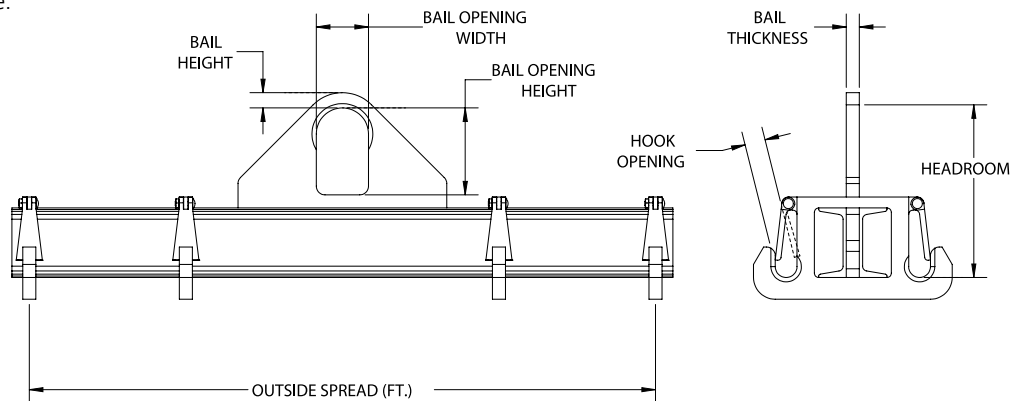

Model #	Capacity (US Tons)*	Outside Spread (Ft.)	Dimensions (Inches)						Weight (Lbs.)
			Headroom	Bail Height	Bail Opening Width	Bail Opening Height	Bail Thickness	Hook Opening	
BSLB-1/2-3	1/2	3	9	0.88	3	5	0.75	1.06	53
BSLB-1/2-4	1/2	4	9	0.88	3	5	0.75	1.06	68
BSLB-1/2-6	1/2	6	9	0.88	3	5	0.75	1.06	116
BSLB-1/2-8	1/2	8	9	0.88	3	5	0.75	1.06	158
BSLB-1/2-10	1/2	10	10	0.88	3	5	0.75	1.06	210
BSLB-1/2-12	1/2	12	10	0.88	3	5	0.75	1.06	231
BSLB-1/2-14	1/2	14	11	0.88	3	5	0.75	1.06	313
BSLB-1/2-16	1/2	16	11	0.88	3	5	0.75	1.06	348
BSLB-1/2-18	1/2	18	12	0.88	3	5	0.75	1.06	445
BSLB-1/2-20	1/2	20	12	0.88	3	5	0.75	1.06	486
BSLB-1/2-24	1/2	24	13	0.88	3	5	0.75	1.06	658
BSLB-1/2-30	1/2	30	14	0.88	3	5	0.75	1.06	898
BSLB-1-3	1	3	9	0.88	3	5	0.75	1.13	53
BSLB-1-4	1	4	9	0.88	3	5	0.75	1.13	68
BSLB-1-6	1	6	10	0.88	3	5	0.75	1.13	152
BSLB-1-8	1	8	11	0.88	3	5	0.75	1.13	221
BSLB-1-10	1	10	11	0.88	3	5	0.75	1.13	242
BSLB-1-12	1	12	12	0.88	3	5	0.75	1.13	305
BSLB-1-14	1	14	12	0.88	3	5	0.75	1.13	355
BSLB-1-16	1	16	13	0.88	3	5	0.75	1.13	410
BSLB-1-18	1	18	14	0.88	3	5	0.75	1.13	566
BSLB-1-20	1	20	14	0.88	3	5	0.75	1.13	617
BSLB-1-24	1	24	16	0.88	3	5	0.75	1.13	952
BSLB-1-30	1	30	16	0.88	3	5	0.75	1.13	1208

\* 1 US Ton = 2,000 Lbs

cont.



**DO NOT EXCEED CAPACITY!**  
See the SAFETY GUIDELINES section before using these products. Pages 92-95.

## BASKET SLING LIFTING BEAM cont.

Model #	Capacity (US Tons)*	Outside Spread (Ft.)	Dimensions (Inches)						Weight (Lbs.)
			Headroom	Bail Height	Bail Opening Width	Bail Opening Height	Bail Thickness	Hook Opening	
BSLB-2-3	2	3	10	0.88	3	5	0.75	1.13	74
BSLB-2-4	2	4	11	0.88	3	5	0.75	1.13	95
BSLB-2-6	2	6	11	0.88	3	5	0.75	1.13	168
BSLB-2-8	2	8	12	0.88	3	5	0.75	1.13	236
BSLB-2-10	2	10	13	0.88	3	5	0.75	1.13	315
BSLB-2-12	2	12	14	0.88	3	5	0.75	1.13	394
BSLB-2-14	2	14	14	0.88	3	5	0.75	1.13	469
BSLB-2-16	2	16	15	0.88	3	5	0.75	1.13	541
BSLB-2-18	2	18	16	0.88	3	5	0.75	1.13	761
BSLB-2-20	2	20	16	0.88	3	5	0.75	1.13	856
BSLB-2-24	2	24	18	0.88	3	5	0.75	1.13	1282
BSLB-2-30	2	30	21	0.88	3	5	0.75	1.13	2386
BSLB-5-3	5	3	14	2	4	7	1	1.13	95
BSLB-5-4	5	4	15	2	4	7	1	1.13	168
BSLB-5-6	5	6	16	2	4	7	1	1.13	289
BSLB-5-8	5	8	17	2	4	7	1	1.13	368
BSLB-5-10	5	10	17	2	4	7	1	1.13	473
BSLB-5-12	5	12	17	2	4	7	1	1.13	525
BSLB-5-14	5	14	19	2	4	7	1.25	1.13	897
BSLB-5-16	5	16	20	2	4	7	1.25	1.13	987
BSLB-5-18	5	18	23	2	4	7	1.25	1.13	1468
BSLB-5-20	5	20	23	2	4	7	1.25	1.13	1733
BSLB-5-24	5	24	23	2	4	7	1.25	1.13	2251
BSLB-5-30	5	30	26	2	4	7	1.25	1.13	2447
BSLB-7.5-3	7.5	3	15	2	4	7	1.25	1.75	158
BSLB-7.5-4	7.5	4	16	2	4	7	1.25	1.75	189
BSLB-7.5-6	7.5	6	17	2	4	7	1.25	1.75	336
BSLB-7.5-8	7.5	8	18	2	4	7	1.25	1.75	431
BSLB-7.5-10	7.5	10	18	2	4	7	1.25	1.75	525
BSLB-7.5-12	7.5	12	20	2	4	7	1.25	1.75	735
BSLB-7.5-14	7.5	14	23	2	4	7	1.25	1.75	1204
BSLB-7.5-16	7.5	16	23	2	4	7	1.25	1.75	1364
BSLB-7.5-18	7.5	18	23	2	4	7	1.25	1.75	1541
BSLB-7.5-20	7.5	20	23	2	4	7	1.25	1.75	1686
BSLB-7.5-24	7.5	24	26	2	4	7	1.25	1.75	2452
BSLB-7.5-30	7.5	30	26	2	4	7	1.25	1.75	3021
BSLB-10-3	10	3	16	2	4	7	1.25	1.75	163
BSLB-10-4	10	4	17	2	4	7	1.25	1.75	210
BSLB-10-6	10	6	18	2	4	7	1.25	1.75	347
BSLB-10-8	10	8	20	2	4	7	1.25	1.75	525
BSLB-10-10	10	10	23	2	4	7	1.25	1.75	893
BSLB-10-12	10	12	20	2	4	7	1.25	1.75	1050
BSLB-10-14	10	14	23	2	4	7	1.25	1.75	1220
BSLB-10-16	10	16	23	2	4	7	1.25	1.75	1365
BSLB-10-18	10	18	26	2	4	7	1.25	1.75	1827
BSLB-10-20	10	20	26	2	4	7	1.25	1.75	2040
BSLB-10-24	10	24	26	2	4	7	1.25	1.75	2472
BSLB-10-30	10	30	26	2	4	7	1.25	1.75	3110

\* 1 US Ton = 2,000 Lbs

cont.



**DO NOT EXCEED CAPACITY!**  
See the SAFETY GUIDELINES section before using these products. Pages 92-95.



## BSLB

### BASKET SLING LIFTING BEAM cont.

#### FEATURES

- This style of lifting beam can be utilized where headroom is limited with slings in a basket hitch.
- Includes two sets of fixed hooks (3' and 4' beams have one set of hooks).
- Two standard lift points for load adjustment; outside lift point & inside lift point (1/2 the overall length).
- Engineered & manufactured to ASME B30.20 & BTH-1 Design Category B Service Class 2.
- 100% of ALL Peerless Lifting Beams are Proof-Tested to 125% capacity & certificates supplied at No Additional Charge.

#### OPTIONS

- Additional lift points
- Higher capacities
- Additional lengths
- Low headroom bail
- Additional hooks
- Sling spacers

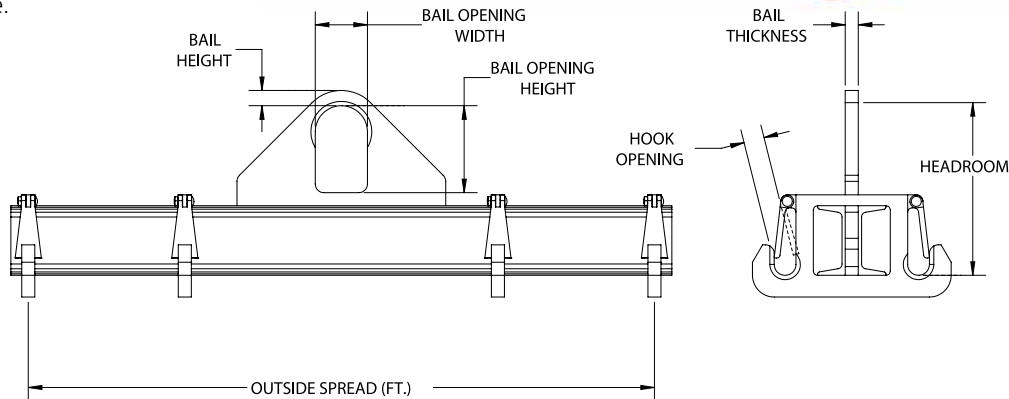
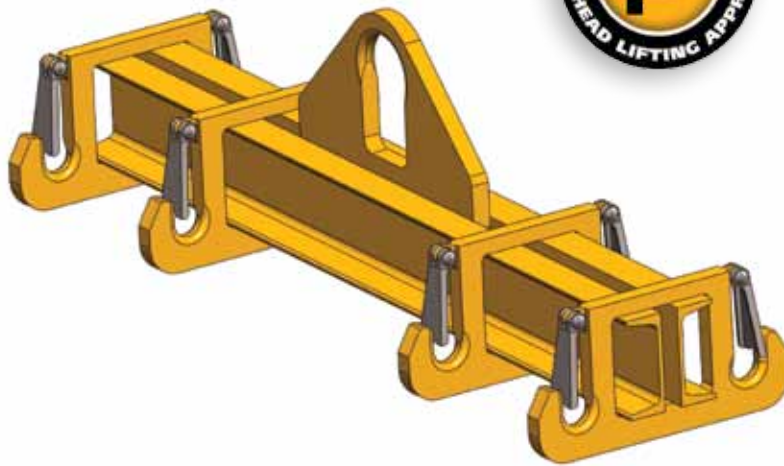

Model #	Capacity (US Tons)*	Outside Spread (Ft.)	Dimensions (Inches)						Weight (Lbs.)
			Headroom	Bail Height	Bail Opening Width	Bail Opening Height	Bail Thickness	Hook Opening	
BSLB-15-3	15	3	19	2.5	5	9	1.5	4	266
BSLB-15-4	15	4	20	2.5	5	9	1.5	4	344
BSLB-15-6	15	6	22	2.5	5	9	1.5	4	956
BSLB-15-8	15	8	22	2.5	5	9	1.5	4	1050
BSLB-15-10	15	10	25	2.5	5	9	1.5	4	1208
BSLB-15-12	15	12	28	2.5	5	9	1.5	4	1827
BSLB-15-14	15	14	28	2.5	5	9	1.5	4	2032
BSLB-15-16	15	16	28	2.5	5	9	1.5	4	2205
BSLB-15-18	15	18	28	2.5	5	9	1.5	4	2511
BSLB-15-20	15	20	28	2.5	5	9	1.5	4	2713
BSLB-15-24	15	24	28	2.5	5	9	1.5	4	3675
BSLB-15-30	15	30	30	2.5	5	9	1.5	4	4305
BSLB-20-3	20	3	20	2.5	5	9	1.5	4	417
BSLB-20-4	20	4	22	2.5	5	9	1.5	4	495
BSLB-20-6	20	6	22	2.5	5	9	1.5	4	1019
BSLB-20-8	20	8	25	2.5	5	9	1.5	4	1302
BSLB-20-10	20	10	25	2.5	5	9	1.5	4	1319
BSLB-20-12	20	12	25	2.5	5	9	1.5	4	2079
BSLB-20-14	20	14	28	2.5	5	9	1.5	4	2168
BSLB-20-16	20	16	28	2.5	5	9	1.5	4	2321
BSLB-20-18	20	18	28	2.5	5	9	1.5	4	2604
BSLB-20-20	20	20	28	2.5	5	9	1.5	4	2893
BSLB-20-24	20	24	31	2.5	5	9	1.5	4	4247
BSLB-20-30	20	30	31	2.5	5	9	1.5	4	4725

\* 1 US Ton = 2,000 Lbs



## DCLB DUAL CRANE LIFTING BEAM

### FEATURES

- This style of lifting beam is utilized with two cranes, where headroom is limited, and comes standard with a swivel hook.
- Roller bearing hook standard on capacities 30 tons and over.
- Engineered and manufactured to ASME B30.20 & BTH-1 Design Category B Service Class 2.
- 100% of ALL Peerless Lifting Beams are Proof-Tested to 125% capacity and certificates supplied at No Additional Charge.

### OPTIONS

- Additional lift points
- Higher capacities
- Additional lengths
- Center bail
- Additional hooks
- Integrated beam stands

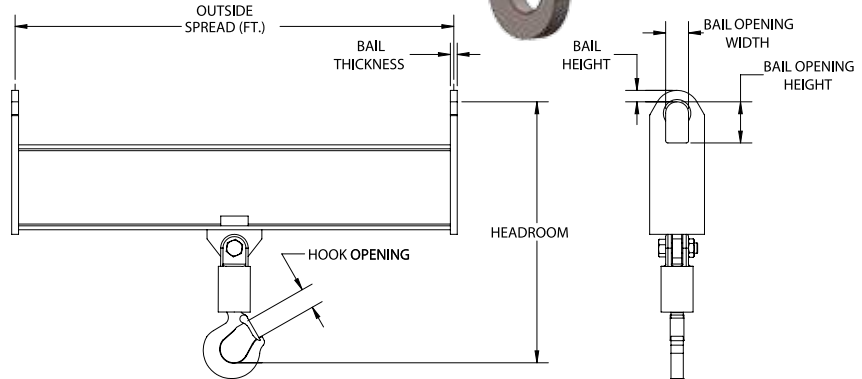
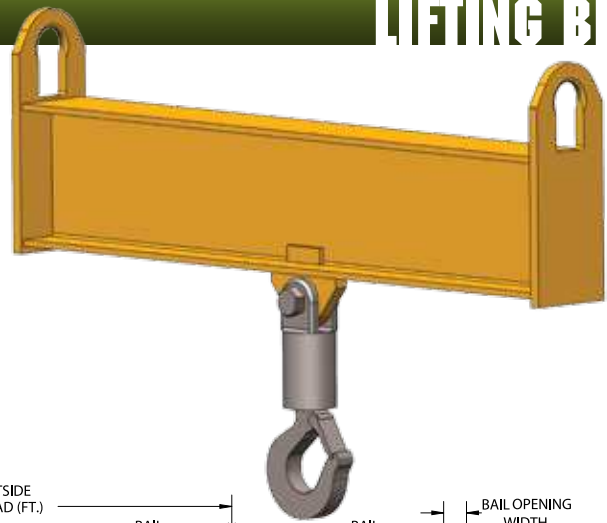

Model #	Capacity (US Tons)*	Outside Spread (Ft.)	Dimensions (Inches)						Weight (Lbs.)
			Headroom	Bail Height	Bail Opening Width	Bail Opening Height	Bail Thickness	Hook Opening	
DCLB-2-6	2	6	17	1.5	3	5	0.63	1.09	125
DCLB-2-8	2	8	17	1.5	3	5	0.63	1.09	160
DCLB-2-10	2	10	18	1.5	3	5	0.63	1.09	240
DCLB-2-12	2	12	18	1.5	3	5	0.63	1.09	280
DCLB-2-14	2	14	19	1.5	3	5	0.63	1.09	360
DCLB-2-16	2	16	19	1.5	3	5	0.63	1.09	400
DCLB-2-18	2	18	19	1.5	3	5	0.63	1.09	530
DCLB-2-20	2	20	19	1.5	3	5	0.63	1.09	660
DCLB-2-24	2	24	20	1.5	3	5	0.63	1.09	790
DCLB-4-6	4	6	20	1.5	3	5	0.63	1.61	160
DCLB-4-8	4	8	21	1.5	3	5	0.63	1.61	240
DCLB-4-10	4	10	22	1.5	3	5	0.63	1.61	310
DCLB-4-12	4	12	23	1.5	3	5	0.63	1.61	410
DCLB-4-14	4	14	23	1.5	3	5	0.63	1.61	500
DCLB-4-16	4	16	25	1.5	3	5	0.63	1.61	725
DCLB-4-18	4	18	25	1.5	3	5	0.63	1.61	805
DCLB-4-20	4	20	25	1.5	3	5	0.63	1.61	890
DCLB-4-24	4	24	26	1.5	3	5	0.63	1.61	1695
DCLB-6-6	6	6	28	1.5	3	5	0.75	2.08	220
DCLB-6-8	6	8	29	1.5	3	5	0.75	2.08	300
DCLB-6-10	6	10	29	1.5	3	5	0.75	2.08	380
DCLB-6-12	6	12	31	1.5	3	5	0.75	2.08	550
DCLB-6-14	6	14	31	1.5	3	5	0.75	2.08	640
DCLB-6-16	6	16	31	1.5	3	5	0.75	2.08	780
DCLB-6-18	6	18	31	1.5	3	5	0.75	2.08	1310
DCLB-6-20	6	20	31	1.5	3	5	0.75	2.08	1450
DCLB-6-24	6	24	32	1.5	3	5	0.75	2.08	1735

\* 1 US Ton = 2,000 Lbs

cont.



**DO NOT EXCEED CAPACITY!**  
See the SAFETY GUIDELINES section before using these products. Pages 92-95.



## DUAL CRANE LIFTING BEAM cont.

### FEATURES

- This style of lifting beam is utilized with two cranes, where headroom is limited, and comes standard with a swivel hook.
- Roller bearing hook standard on capacities 30 tons and over.
- Engineered and manufactured to ASME B30.20 & BTH-1 Design Category B Service Class 2.
- 100% of ALL Peerless Lifting Beams are Proof-Tested to 125% capacity and certificates supplied at No Additional Charge.

### OPTIONS

- Additional lift points
- Higher capacities
- Additional lengths
- Center bail
- Additional hooks
- Integrated beam stands

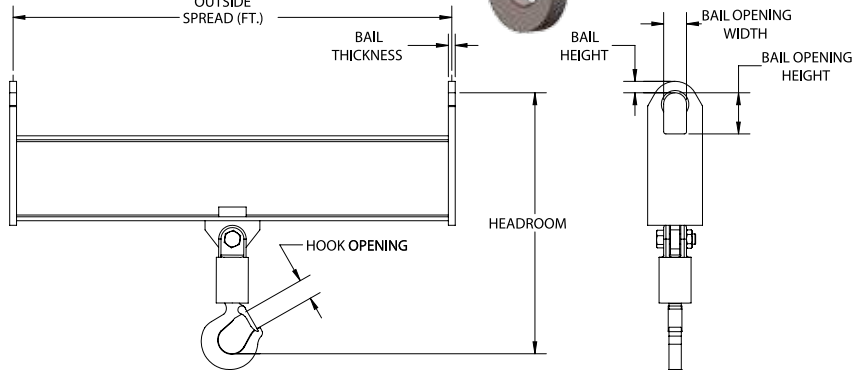
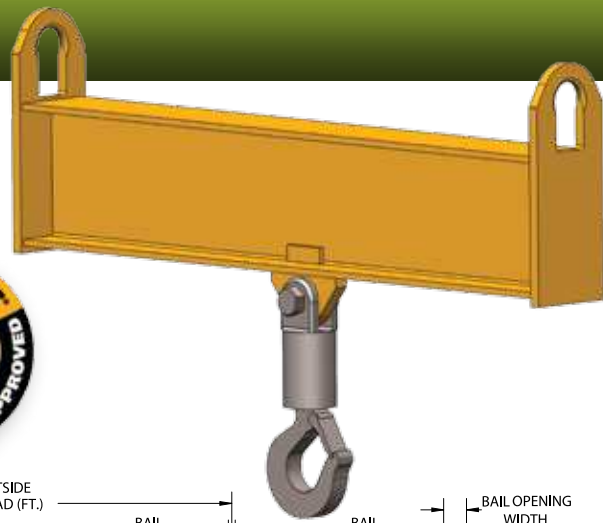

Model #	Capacity (US Tons)*	Outside Spread (Ft.)	Dimensions (Inches)						Weight (Lbs.)
			Headroom	Bail Height	Bail Opening Width	Bail Opening Height	Bail Thickness	Hook Opening	
DCLB-10-6	10	6	29	2	4	7	1	2.27	340
DCLB-10-8	10	8	29	2	4	7	1	2.27	420
DCLB-10-10	10	10	32	2	4	7	1	2.27	800
DCLB-10-12	10	12	32	2	4	7	1	2.27	920
DCLB-10-14	10	14	32	2	4	7	1	2.27	1100
DCLB-10-16	10	16	32	2	4	7	1	2.27	1220
DCLB-10-18	10	18	32	2	4	7	1	2.27	1705
DCLB-10-20	10	20	32	2	4	7	1	2.27	1840
DCLB-10-24	10	24	33	2	4	7	1	2.27	2230
DCLB-15-8	15	8	38	2	4	7	1.25	3.02	814
DCLB-15-10	15	10	38	2	4	7	1.25	3.02	952
DCLB-15-12	15	12	38	2	4	7	1.25	3.02	1155
DCLB-15-14	15	14	41	2	4	7	1.25	3.02	2123
DCLB-15-16	15	16	41	2	4	7	1.25	3.02	2374
DCLB-15-18	15	18	42	2	4	7	1.25	3.02	2519
DCLB-15-20	15	20	42	2	4	7	1.25	3.02	2750
DCLB-15-24	15	24	42	2	4	7	1.25	3.02	2860
DCLB-20-8	20	8	36	2	4	7	1.25	3.02	913
DCLB-20-10	20	10	39	2	4	7	1.25	3.02	1243
DCLB-20-12	20	12	39	2	4	7	1.25	3.02	1393
DCLB-20-14	20	14	39	2	4	7	1.25	3.02	2119
DCLB-20-16	20	16	39	2	4	7	1.25	3.02	2416
DCLB-20-18	20	18	39	2	4	7	1.25	3.02	2673
DCLB-20-20	20	20	39	2	4	7	1.25	3.02	2783
DCLB-30-8	30	8	54	2.5	5	9	1.5	3.75	1232
DCLB-30-10	30	10	54	2.5	5	9	1.5	3.75	1458
DCLB-30-12	30	12	54	2.5	5	9	1.5	3.75	1771
DCLB-40-8	40	8	59	2.5	5	9	1.5	4.25	1282
DCLB-40-10	40	10	59	2.5	5	9	1.5	4.25	1617
DCLB-40-12	40	12	59	2.5	5	9	1.5	4.25	1870

\* 1 US Ton = 2,000 Lbs



**DO NOT EXCEED CAPACITY!**  
See the SAFETY GUIDELINES section before using these products. Pages 92-95.





## UNIVERSAL LIFTING/SPREADER BEAM

### FEATURES

- This style of universal beam can be utilized as a lifting beam where headroom is limited or a spreader beam where extra stability is required.
- As a lifting beam, the upper lift point can be easily adjusted to lift an off center load.
- Can be configured as an optional three or four point lifting system
- Can be supplied with optional chain top rigging.
- Supplied with one upper shackle for adjustable bail positions and two lower shackles for adjustable spreads.
- Engineered and manufactured to ASME B30.20 & BTH-1 Design Category B Service Class 2.
- 100% of ALL Peerless Lifting Beams are Proof-Tested to 125% capacity and certificates supplied at No Additional Charge.

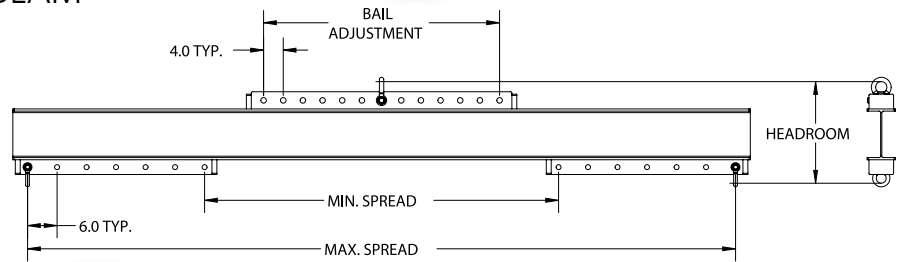

### OPTIONS

- Chain top rigging
- Three point lifting system
- Four point lifting system
- Additional lift points and spreads
- Higher capacities
- Additional lengths
- Swivel hooks

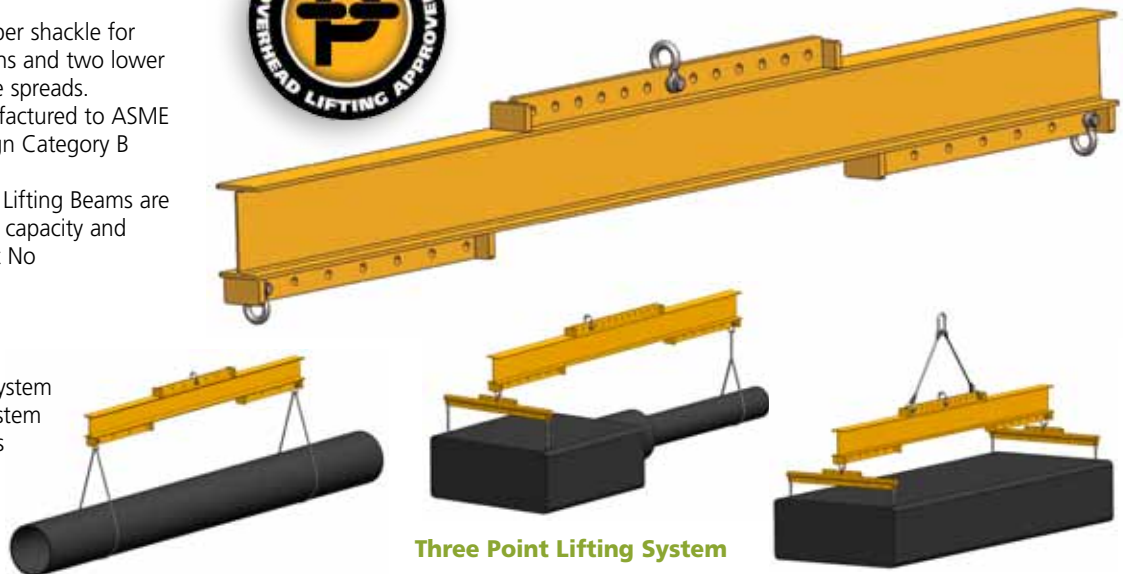

Two Point Lifting Beam

Three Point Lifting System

Four Point Lifting System

Model #	Capacity (US Tons)*	Max. Spread (Ft.)	Min. Spread (Ft.)	Dimensions (Inches)				Weight (Lbs.)
				Bail Adjustment	Headroom	Top Shackle (Tons)	Bottom Shackle (Tons)	
UNVB-1/4-4	1/4	4	1	16	8	1.5	1.5	45
UNVB-1/2-4	1/2	4	1	16	8	1.5	1.5	45
UNVB-1/2-6	1/2	6	3	24	9.875	1.5	1.5	80
UNVB-1/2-8	1/2	8	4	32	11	1.5	1.5	135
UNVB-1/2-10	1/2	10	5	40	11	1.5	1.5	145
UNVB-1-6	1	6	3	24	11	1.5	1.5	100
UNVB-1-8	1	8	4	32	12	1.5	1.5	140
UNVB-1-10	1	10	5	40	12	1.5	1.5	175
UNVB-2-6	2	6	3	24	14	3.25	2	130
UNVB-2-8	2	8	4	32	15	3.25	2	200
UNVB-2-10	2	10	5	40	16	3.25	2	280
UNVB-4-8	4	8	4	32	18	4.75	4.75	290
UNVB-4-10	4	10	5	40	20	4.75	4.75	420
UNVB-4-12	4	12	6	48	20	4.75	4.75	500
UNVB-5-8	5	8	4	32	20	6.5	4.75	320
UNVB-5-10	5	10	5	40	21	6.5	4.75	465
UNVB-5-12	5	12	6	48	21	6.5	4.75	550
UNVB-7-12	7	12	6	48	25	6.5	6.5	790

\* 1 US Ton = 2,000 Lbs



**DO NOT EXCEED CAPACITY!**  
See the SAFETY GUIDELINES section before using these products. Pages 92-95.



## ADJUSTABLE LIFTING BEAM

### FEATURES

- This style of lifting beam can lift off center loads easily by adjusting the bail prior to the lift.
- This lifter can be used where headroom is limited, & comes with multiple spreads that are adjustable to accommodate various load sizes at 6" adjustable increments.
- Supplied with two lower shackles.
- Engineered and manufactured to ASME B30.20 & BTH-1 Design Category B Service Class 2.
- 100% of ALL Peerless Lifting Beams are Proof-Tested to 125% capacity and certificates supplied at No Additional Charge.

### OPTIONS

- Swivel hooks

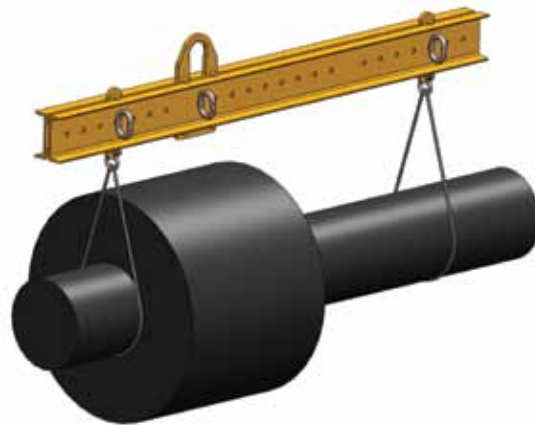
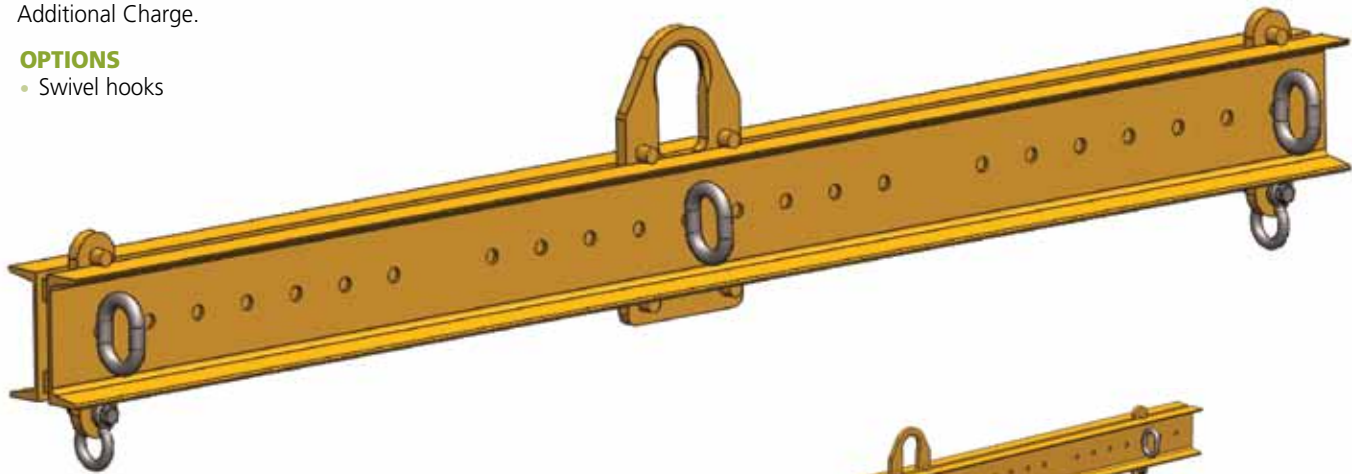
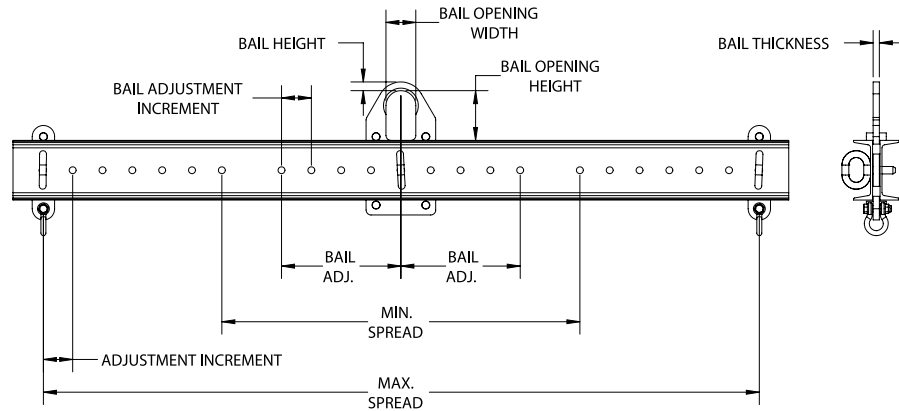

Model #	Capacity (US Tons)*	Max. Spread (Ft.)	Min. Spread (Ft.)	Dimensions (Inches)								Shackle Size (Tons)	Weight (Lbs.)
				Head-room	Bail Height	Bail Opening Width	Bail Opening Height	Bail Thickness	Bail Adjustment Increments	Bail Travel (Half of Center)			
ALB-1.25-6	1.25	6	3	13.5	1	3	5	0.63	3	12	2	120	
ALB-2-6	2	6	3	14.5	1	3	5	0.63	3	12	2	140	
ALB-4-8	4	8	4.5	20	1.5	4	7	0.75	6	18	3.25	315	
ALB-5-10	5	10	5	22	1.5	4	7	1.00	6	18	4.75	440	

\* 1 US Ton = 2,000 Lbs



**DO NOT EXCEED CAPACITY!**  
See the SAFETY GUIDELINES section before using these products. Pages 92-95.



## ABLB ADJUSTABLE BAIL LIFTING BEAM

### FEATURES

- This style of lifting beam can lift off center loads easily by adjusting the bail prior to the lift.
- This lifter can be used where headroom is limited, & comes standard with one outside spread and two swivel hooks (additional spreads & swivel hooks are available).
- Engineered & manufactured to ASME B30.20 & BTH-1 Design Category B Service Class 2.
- 100% of ALL Peerless Lifting Beams are Proof-Tested to 125% capacity & certificates supplied at No Additional Charge.

### OPTIONS

- Additional lift points
- Higher capacities
- Additional lengths
- Low headroom bail
- Additional hooks
- Faspins
- Integrated beam stands

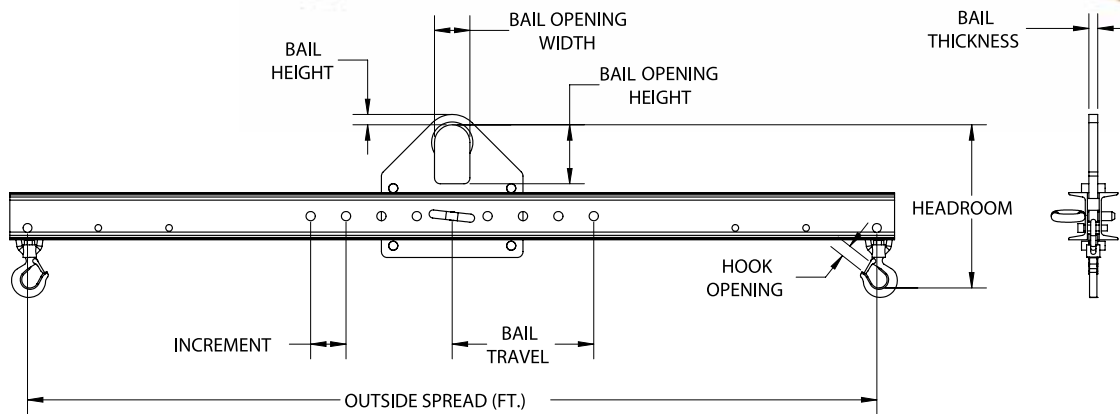
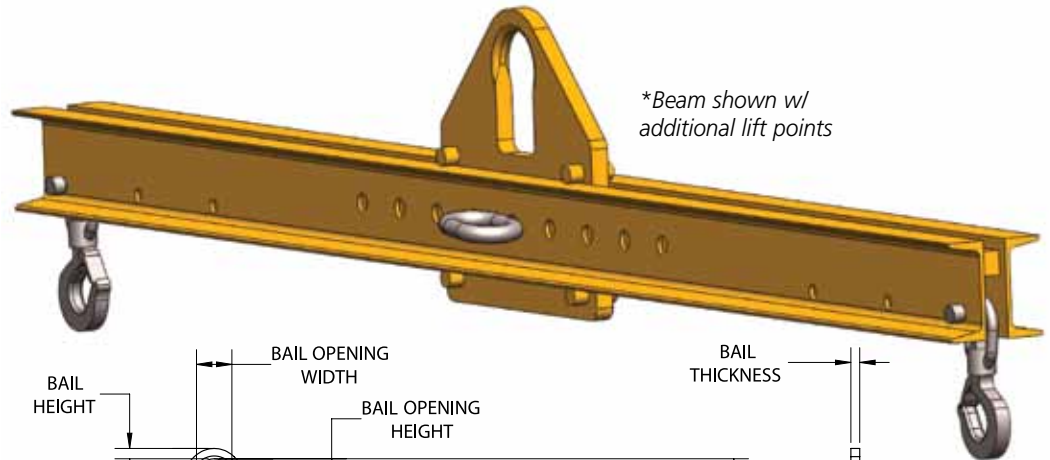

Model #	Capacity (US Tons)*	Outside Spread (Ft.)	Dimensions (Inches)								Weight (Lbs.)
			Head-room	Bail Height	Bail Opening Width	Bail Opening Height	Bail Thickness	Hook Opening	Bail Adjustment Increments	Bail Travel (Half of Center)	
ABLB-1/2-3	1/2	3	14	1.5	3	5	0.63	1	3	6	52
ABLB-1/2-4	1/2	4	14	1.5	3	5	0.63	1	3	9	62
ABLB-1/2-6	1/2	6	14	1.5	3	5	0.63	1	3	12	83
ABLB-1/2-8	1/2	8	14	1.5	3	5	0.63	1	4	16	90
ABLB-1/2-10	1/2	10	14	1.5	3	5	0.63	1	4	20	105
ABLB-1/2-12	1/2	12	14	1.5	3	5	0.63	1	4	24	162
ABLB-1/2-14	1/2	14	14	1.5	3	5	0.63	1	6	30	185
ABLB-1/2-16	1/2	16	15	1.5	3	5	0.63	1	6	36	281
ABLB-1/2-18	1/2	18	15	1.5	3	5	0.63	1	6	42	306
ABLB-1/2-20	1/2	20	15	1.5	3	5	0.63	1	6	48	334
ABLB-1-3	1	3	14	1.5	3	5	0.63	1	3	6	52
ABLB-1-4	1	4	14	1.5	3	5	0.63	1	3	9	62
ABLB-1-6	1	6	14	1.5	3	5	0.63	1	3	12	91
ABLB-1-8	1	8	15	1.5	3	5	0.63	1	4	16	139
ABLB-1-10	1	10	15	1.5	3	5	0.63	1	4	20	187
ABLB-1-12	1	12	15	1.5	3	5	0.63	1	4	24	218
ABLB-1-14	1	14	16	1.5	3	5	0.63	1	6	30	295

\* 1 US Ton = 2,000 Lbs

cont.



**DO NOT EXCEED CAPACITY!**  
See the SAFETY GUIDELINES section before using these products. Pages 92-95.



## ADJUSTABLE BAIL LIFTING BEAM cont.



### FEATURES

- This style of lifting beam can lift off center loads easily by adjusting the bail prior to the lift.
- This lifter can be used where headroom is limited, & comes standard with one outside spread and two swivel hooks (additional spreads & swivel hooks are available).
- Engineered & manufactured to ASME B30.20 & BTH-1 Design Category B Service Class 2.
- 100% of ALL Peerless Lifting Beams are Proof-Tested to 125% capacity & certificates supplied at No Additional Charge.

### OPTIONS

- Additional lift points
- Higher capacities
- Additional lengths
- Low headroom bail
- Additional hooks
- Faspins
- Integrated beam stands

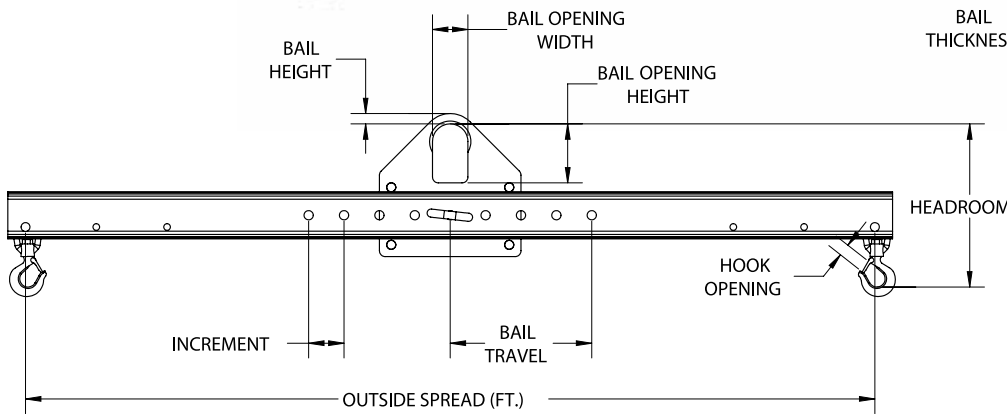
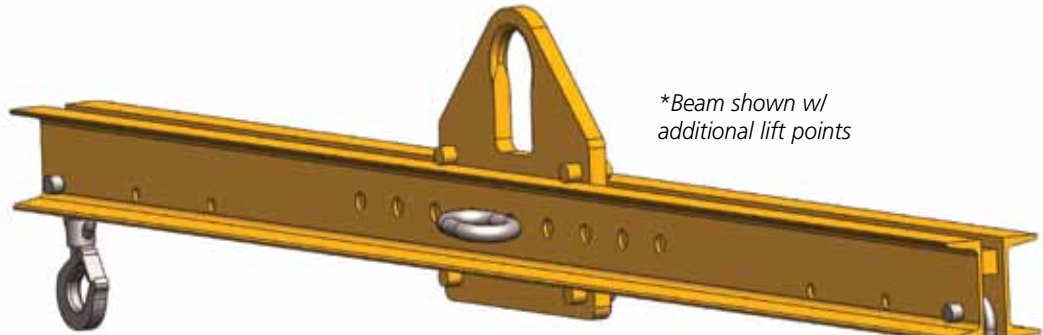

Model #	Capacity (US Tons)*	Outside Spread (Ft.)	Dimensions (Inches)								Weight (Lbs.)
			Head-room	Bail Height	Bail Opening Width	Bail Opening Height	Bail Thickness	Hook Opening	Bail Adjustment Increments	Bail Travel (Half of Center)	
ABLB-1-16	1	16	16	1.5	3	5	0.63	1	6	36	328
ABLB-1-18	1	18	17	1.5	3	5	0.63	1	6	42	450
ABLB-1-20	1	20	17	1.5	3	5	0.63	1	6	48	494
ABLB-2-3	2	3	14	1.5	3	5	0.75	1	3	6	53
ABLB-2-4	2	4	15	1.5	3	5	0.75	1	3	9	98
ABLB-2-6	2	6	15	1.5	3	5	0.75	1	3	12	129
ABLB-2-8	2	8	16	1.5	3	5	0.75	1	4	16	187
ABLB-2-10	2	10	19	1.5	3	5	0.75	1	4	20	264
ABLB-2-12	2	12	17	1.5	3	5	0.75	1	4	24	306
ABLB-2-14	2	14	18	1.5	3	5	0.75	1	6	30	406
ABLB-2-16	2	16	18	1.5	3	5	0.75	1	6	36	458
ABLB-2-18	2	18	20	1.5	3	5	0.75	1	6	42	602
ABLB-2-20	2	20	20	1.5	3	5	0.75	1	6	48	666
ABLB-5-3	5	3	22	2	4	7	1	1.36	3	6	154
ABLB-5-4	5	4	22	2	4	7	1	1.36	3	9	176
ABLB-5-6	5	6	22	2	4	7	1	1.36	3	12	237
ABLB-5-8	5	8	23	2	4	7	1	1.36	4	16	334

\* 1 US Ton = 2,000 Lbs

cont.



**DO NOT EXCEED CAPACITY!**  
See the SAFETY GUIDELINES section before using these products. Pages 92-95.

## ADJUSTABLE BAIL LIFTING BEAM cont.

Model #	Capacity (US Tons)*	Outside Spread (Ft.)	Dimensions (Inches)								Weight (Lbs.)
			Head-room	Bail Height	Bail Opening Width	Bail Opening Height	Bail Thickness	Hook Opening	Bail Adjustment Increments	Bail Travel (Half of Center)	
ABLB-5-10	5	10	24	2	4	7	1	1.36	4	20	473
ABLB-5-12	5	12	27	2	4	7	1	1.36	4	24	696
ABLB-5-14	5	14	27	2	4	7	1	1.36	6	30	730
ABLB-5-16	5	16	28	2	4	7	1	1.36	6	36	821
ABLB-5-18	5	18	29	2	4	7	1	1.36	6	42	1453
ABLB-5-20	5	20	30	2	4	7	1	1.36	6	48	1678
ABLB-10-3	10	3	26	2	4	7	1.25	2.08	3	6	231
ABLB-10-4	10	4	26	2	4	7	1.25	2.08	3	9	232
ABLB-10-6	10	6	29	2	4	7	1.25	2.08	3	12	475
ABLB-10-8	10	8	29	2	4	7	1.25	2.08	4	16	574
ABLB-10-10	10	10	32	2	4	7	1.25	2.08	4	20	835
ABLB-10-12	10	12	32	2	4	7	1.25	2.08	4	24	1092
ABLB-10-14	10	14	32	2	4	7	1.25	2.08	6	30	1241
ABLB-10-16	10	16	32	2	4	7	1.25	2.08	6	36	1383
ABLB-10-18	10	18	35	2	4	7	1.25	2.08	6	42	1679
ABLB-10-20	10	20	35	2	4	7	1.25	2.08	6	48	1744
ABLB-15-3	15	3	28	2.5	5	9	1.5	2.27	3	6	277
ABLB-15-4	15	4	31	2.5	5	9	1.5	2.27	3	9	363
ABLB-15-6	15	6	34	2.5	5	9	1.5	2.27	3	12	552
ABLB-15-8	15	8	34	2.5	5	9	1.5	2.27	4	16	596
ABLB-15-10	15	10	34	2.5	5	9	1.5	2.27	4	20	970
ABLB-15-12	15	12	37	2.5	5	9	1.5	2.27	4	24	1486
ABLB-15-14	15	14	37	2.5	5	9	1.5	2.27	6	30	1540
ABLB-15-16	15	16	37	2.5	5	9	1.5	2.27	6	36	1623
ABLB-15-18	15	18	37	2.5	5	9	1.5	2.27	6	42	1912
ABLB-15-20	15	20	37	2.5	5	9	1.5	2.27	6	48	2099
ABLB-20-3	20	3	31	2.5	5	9	1.5	2.27	3	6	347
ABLB-20-4	20	4	34	2.5	5	9	1.5	2.27	3	9	439
ABLB-20-6	20	6	37	2.5	5	9	1.5	2.27	3	12	809
ABLB-20-8	20	8	37	2.5	5	9	1.5	2.27	4	16	792
ABLB-20-10	20	10	37	2.5	5	9	1.5	2.27	4	20	1404
ABLB-20-12	20	12	37	2.5	5	9	1.5	2.27	4	24	1601
ABLB-20-14	20	14	37	2.5	5	9	1.5	2.27	6	30	1793
ABLB-20-16	20	16	37	2.5	5	9	1.5	2.27	6	36	1980
ABLB-20-18	20	18	37	2.5	5	9	1.5	2.27	6	42	2063
ABLB-20-20	20	20	37	2.5	5	9	1.5	2.27	6	48	2129

\* 1 US Ton = 2,000 Lbs



**DO NOT EXCEED CAPACITY!**  
See the SAFETY GUIDELINES section before using these products. Pages 92-95.



## LLB LOAD LEVELING BEAM

### FEATURES

- This style of lifting beam can lift off center loads easily by adjusting the bail with the standard chain wheel prior to the lift and has unlimited adjustment within the span of the bail.
- This lifter can be used where headroom is limited, and comes standard with one outside spread and two swivel hooks (additional spreads and swivel hooks are available).
- Engineered and manufactured to ASME B30.20 & BTH-1 Design Category B Service Class 2.
- 100% of ALL Peerless Lifting Beams are Proof-Tested to 125% capacity and certificates supplied at No Additional Charge.

### OPTIONS

- Motorized bail
- Additional lift points
- Higher capacities
- Additional lengths
- Low headroom bail
- Additional hooks
- Faspins
- Beam stand

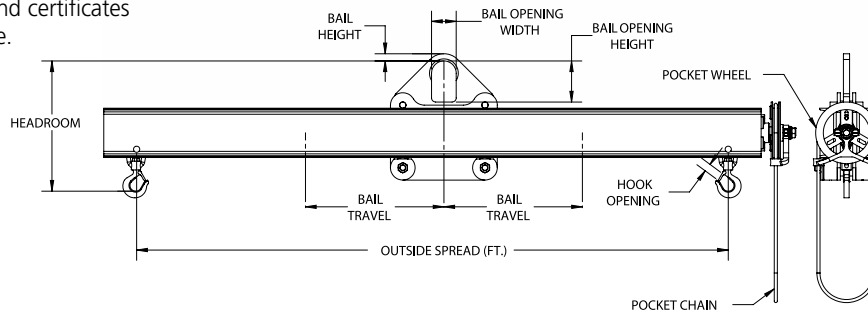
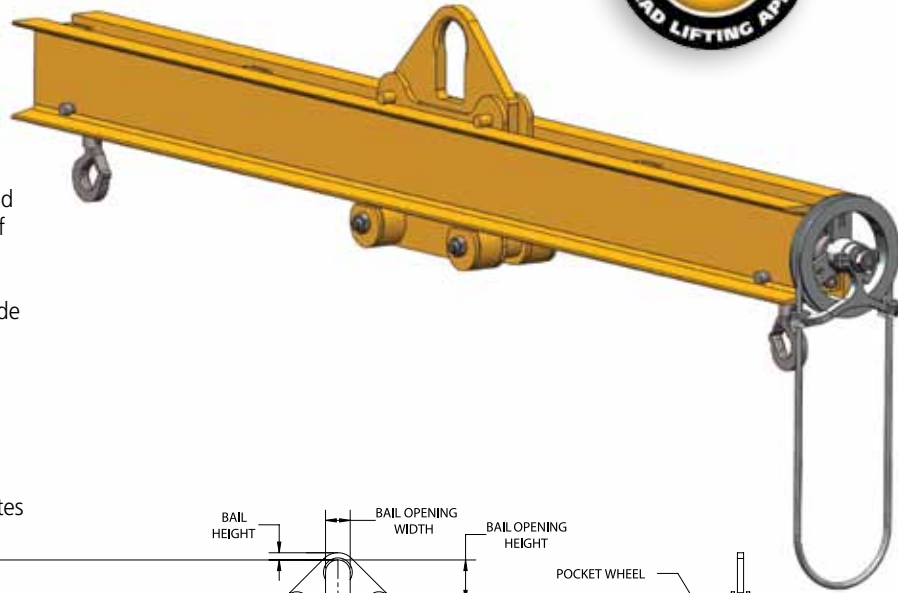

Model #	Capacity (US Tons)*	Outside Spread (Ft.)	Dimensions (Inches)							Weight (Lbs.)
			Headroom	Bail Height	Bail Opening Width	Bail Opening Height	Bail Thickness	Hook Opening	Bail Travel (Half of Center)	
LLB-2-4	2	4	16	1.5	3	5	0.63	1	8	169
LLB-2-6	2	6	16	1.5	3	5	0.63	1	12	231
LLB-2-8	2	8	17	1.5	3	5	0.63	1	16	325
LLB-2-10	2	10	18	1.5	3	5	0.63	1	20	411
LLB-2-12	2	12	18	1.5	3	5	0.63	1	24	471
LLB-2-14	2	14	19	1.5	3	5	0.63	1	28	601
LLB-2-16	2	16	19	1.5	3	5	0.63	1	32	673
LLB-2-18	2	18	20	1.5	3	5	0.63	1	36	850
LLB-2-20	2	20	20	1.5	3	5	0.63	1	40	938
LLB-2-24	2	24	21	1.5	3	5	0.63	1	48	1581
LLB-5-4	5	4	23	2	4	7	1	1.36	8	213
LLB-5-6	5	6	23	2	4	7	1	1.36	12	338
LLB-5-8	5	8	25	2	4	7	1	1.36	16	478
LLB-5-10	5	10	25	2	4	7	1	1.36	20	594
LLB-5-12	5	12	27	2	4	7	1	1.36	24	851
LLB-5-14	5	14	27	2	4	7	1	1.36	28	971
LLB-5-16	5	16	27	2	4	7	1	1.36	32	1188
LLB-5-18	5	18	30	2	4	7	1	1.36	36	1819
LLB-5-20	5	20	30	2	4	7	1	1.36	40	2004
LLB-5-24	5	24	30	2	4	7	1	1.36	48	2931
LLB-10-4	10	4	27	2	4	7	1.25	2.08	8	321
LLB-10-6	10	6	30	2	4	7	1.25	2.08	12	550
LLB-10-8	10	8	30	2	4	7	1.25	2.08	16	625
LLB-10-10	10	10	33	2	4	7	1.25	2.08	20	1175
LLB-10-12	10	12	33	2	4	7	1.25	2.08	24	1368

\* 1 US Ton = 2,000 Lbs

cont.



**DO NOT EXCEED CAPACITY!**  
See the SAFETY GUIDELINES section before using these products. Pages 92-95.

## LOAD LEVELING BEAM cont.

Model #	Capacity (US Tons)*	Outside Spread (Ft.)	Dimensions (Inches)							Weight (Lbs.)
			Headroom	Bail Height	Bail Opening Width	Bail Opening Height	Bail Thickness	Hook Opening	Bail Travel (Half of Center)	
LLB-10-14	10	14	33	2	4	7	1.25	2.08	28	1554
LLB-10-16	10	16	33	2	4	7	1.25	2.08	32	1735
LLB-10-18	10	18	36	2	4	7	1.25	2.08	36	2344
LLB-10-20	10	20	36	2	4	7	1.25	2.08	40	2406
LLB-10-24	10	24	36	2	4	7	1.25	2.08	48	3063
LLB-15-4	15	4	32	2.5	5	9	1.5	2.27	8	470
LLB-15-6	15	6	35	2.5	5	9	1.5	2.27	12	706
LLB-15-8	15	8	35	2.5	5	9	1.5	2.27	16	778
LLB-15-10	15	10	35	2.5	5	9	1.5	2.27	20	1215
LLB-15-12	15	12	38	2.5	5	9	1.5	2.27	24	1649
LLB-15-14	15	14	38	2.5	5	9	1.5	2.27	28	1773
LLB-15-16	15	16	38	2.5	5	9	1.5	2.27	32	1891
LLB-15-18	15	18	38	2.5	5	9	1.5	2.27	36	2375
LLB-15-20	15	20	38	2.5	5	9	1.5	2.27	40	2570
LLB-15-24	15	24	38	2.5	5	9	1.5	2.27	48	3200
LLB-20-4	20	4	35	2.5	5	9	1.5	2.27	8	556
LLB-20-6	20	6	38	2.5	5	9	1.5	2.27	12	998
LLB-20-8	20	8	38	2.5	5	9	1.5	2.27	16	1125
LLB-20-10	20	10	38	2.5	5	9	1.5	2.27	20	1313
LLB-20-12	20	12	38	2.5	5	9	1.5	2.27	24	2813
LLB-20-14	20	14	38	2.5	5	9	1.5	2.27	28	2938
LLB-20-16	20	16	38	2.5	5	9	1.5	2.27	32	3063
LLB-20-18	20	18	38	2.5	5	9	1.5	2.27	36	3688
LLB-20-20	20	20	38	2.5	5	9	1.5	2.27	40	3938
LLB-20-24	20	24	38	2.5	5	9	1.5	2.27	48	4188

\* 1 US Ton = 2,000 Lbs

## Overhead Lifting Accessories

To view our complete product line of Overhead Lifting Accessories visit us online at [www.peerlesschain.com](http://www.peerlesschain.com) or see the Peerless Industrial Group Catalog 27.12.



**DO NOT EXCEED CAPACITY!**  
See the SAFETY GUIDELINES section before using these products. Pages 92-95.

## TPLB

### THREE POINT LIFTING BEAM

#### FEATURES

- This style of lifting beam can be utilized where headroom is limited and when lifting objects that require multiple lift points.
- Designed to meet your specific lifting requirements.
- Engineered and manufactured to ASME B30.20 & BTH-1 Design Category B Service Class 2.
- 100% of ALL Peerless Lifting Beams are Proof-Tested to 125% capacity and certificates supplied at No Additional Charge.

#### OPTIONS

- Multiple lift points
- Dual bails
- Low headroom bail
- Adjustable spread
- Adjustable bail
- Swivel hooks
- Shackle lugs
- Faspins
- Beam stand

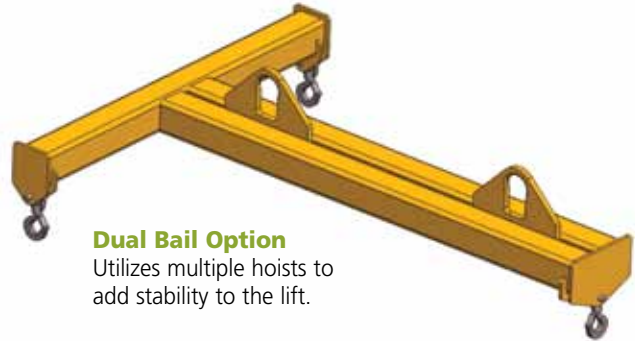

#### Dual Bail Option

Utilizes multiple hoists to add stability to the lift.

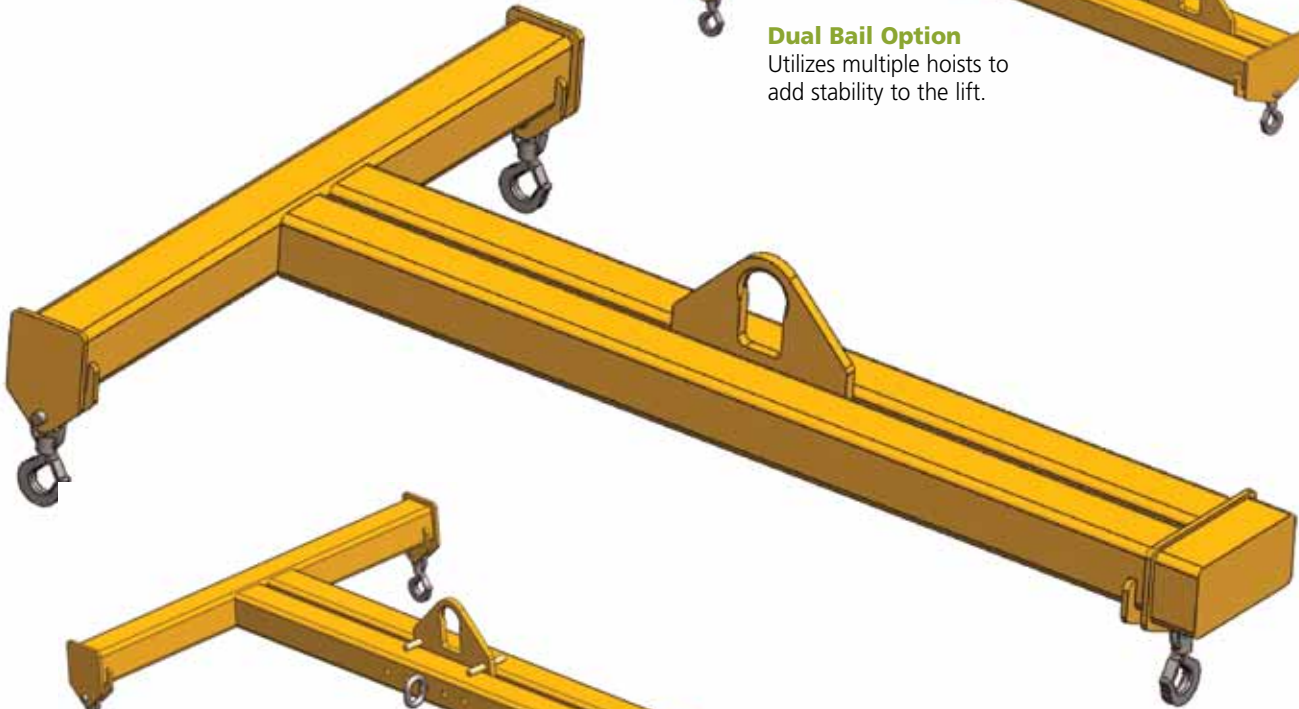

#### Adjustable Bail Option

Provides the option for leveling the load along the length.



#### Adjustable Lift Points Option

Provides the option for leveling the load along the length and width.





## FOUR POINT LIFTING BEAM

### FEATURES

- This style of lifting beam can be utilized where headroom is limited and when lifting objects that require multiple lift points.
- Designed to meet your specific lifting requirements.
- Engineered and manufactured to ASME B30.20 & BTH-1 Design Category B Service Class 2.
- 100% of ALL Peerless Lifting Beams are Proof-Tested to 125% capacity and certificates supplied at No Additional Charge.

### OPTIONS

- Multiple lift points
- Dual bails
- Low headroom bail
- Adjustable spread
- Adjustable bail
- Swivel hooks
- Drop chains
- Shackle lugs
- Faspins
- Beam stand

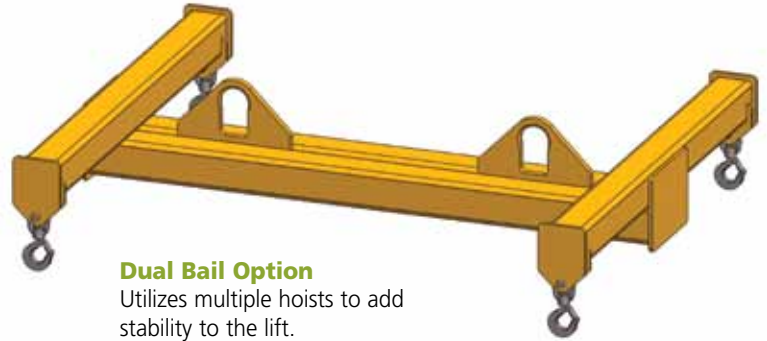

#### Dual Bail Option

Utilizes multiple hoists to add stability to the lift.

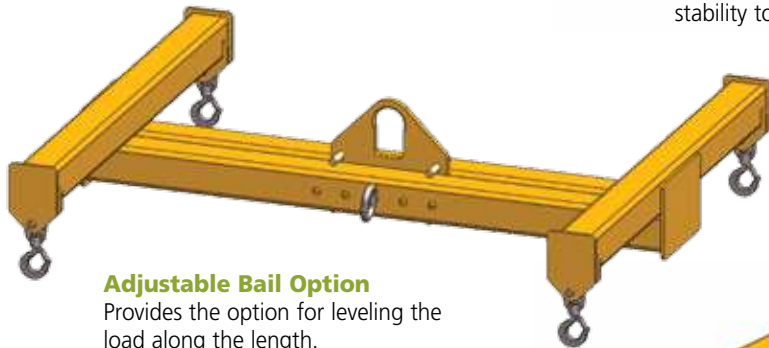

#### Adjustable Bail Option

Provides the option for leveling the load along the length.



#### Adjustable Lift Points Option

Provides the option for leveling the load along the length and width.

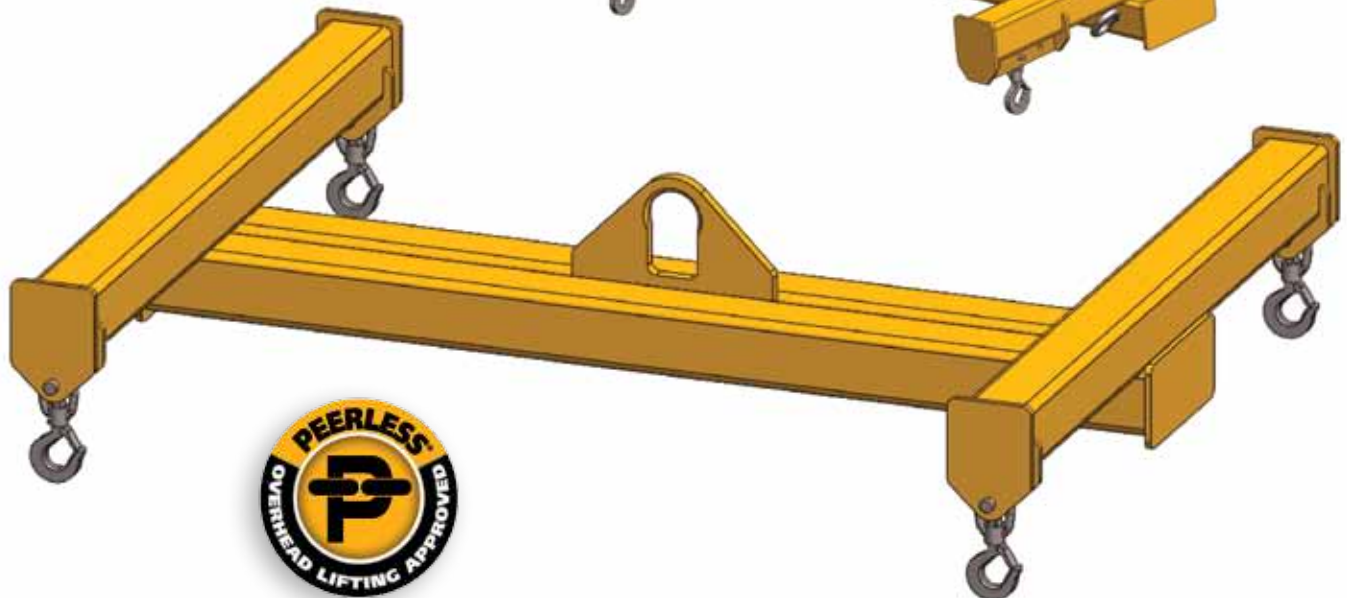

**DO NOT EXCEED CAPACITY!**  
See the SAFETY GUIDELINES section before using these products. Pages 92-95.



## FOUR POINT SACK LIFTER BEAM

### FEATURES

- This style of lifting beam is designed to lift bulk container sacks.
- Standard Sling Keeper design provides improved sling containment during the lift.
- Low headroom design that meets metric rating requirements.
- Smooth edge design to minimize wear on lifting straps.
- Engineered and manufactured to ASME B30.20 & BTH-1 Design Category B Service Class 2.
- 100% of ALL Peerless Lifting Beams are Proof-Tested to 125% capacity and certificates supplied at No Additional Charge.

### OPTIONS

- Sling spacers
- Additional sizes are available

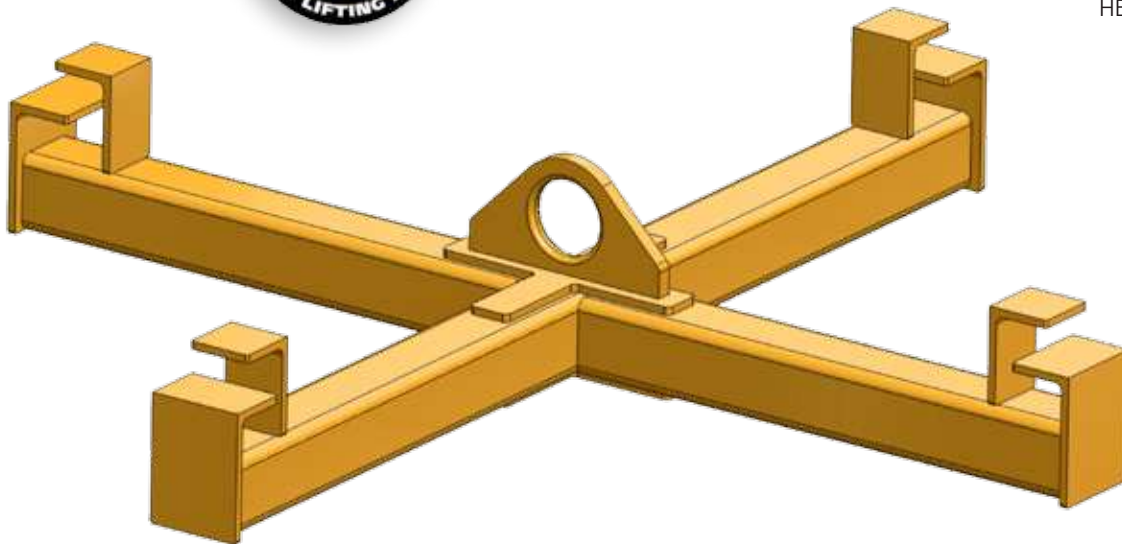
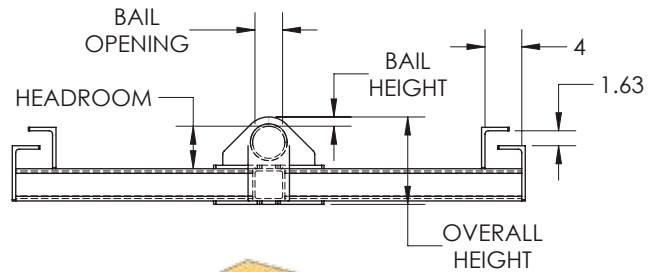
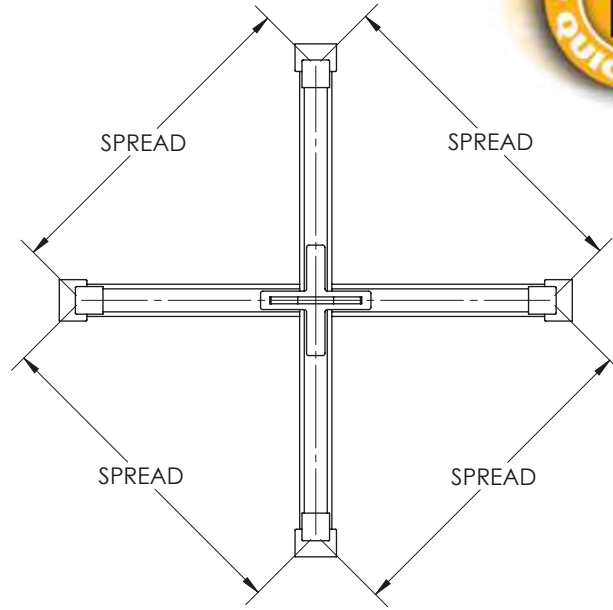

Model #	Capacity (Metric Tons)	Dimensions (Inches)					Weight (Lbs.)
		Outside Spread	Headroom	Bail Height	Bail Opening	Overall Height	
FPSL-1-36SK	1	36	4.63	1	3.5	9	120
FPSL-1-48SK	1	48	4.63	1	3.5	9	145
FPSL-2-36SK	2	36	4.63	1	3.5	9.5	140
FPSL-2-48SK	2	48	4.63	1	3.5	9.5	170





## FOUR POINT ADJUSTABLE BEAM

### FEATURES

- This standard four point adjustable spread style of lifting beam can be utilized where headroom is limited and when lifting objects that require multiple lift points.
- Supplied with four swivel hooks.
- Engineered and manufactured to ASME B30.20 & BTH-1 Design Category B Service Class 2.
- 100% of ALL Peerless Lifting Beams are Proof-Tested to 125% capacity and certificates supplied at No Additional Charge.

### OPTIONS

- Beam stand
- Additional sizes and options are available

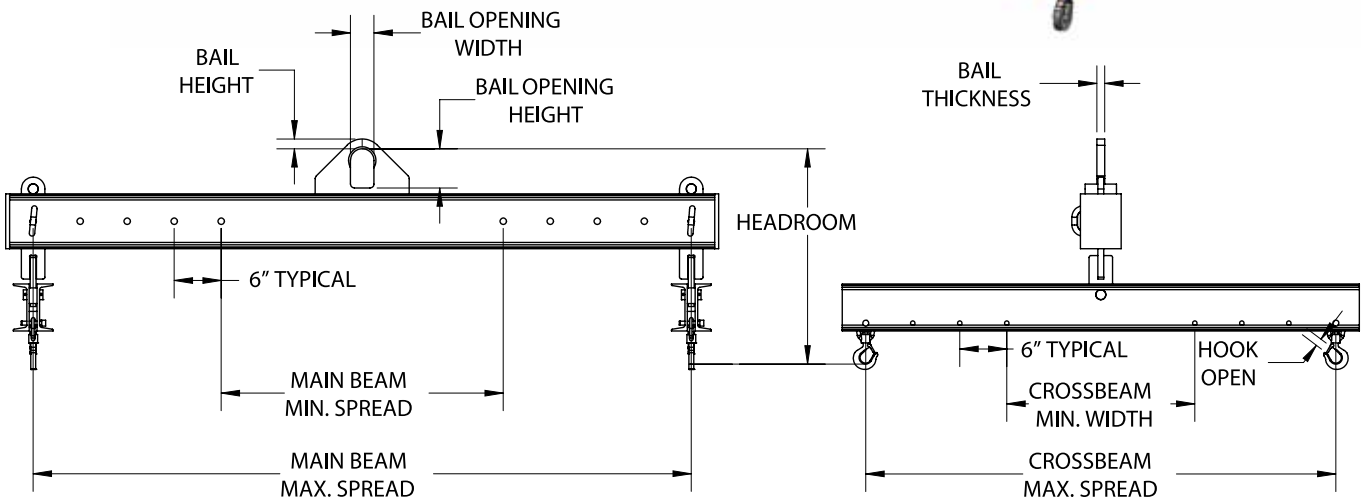
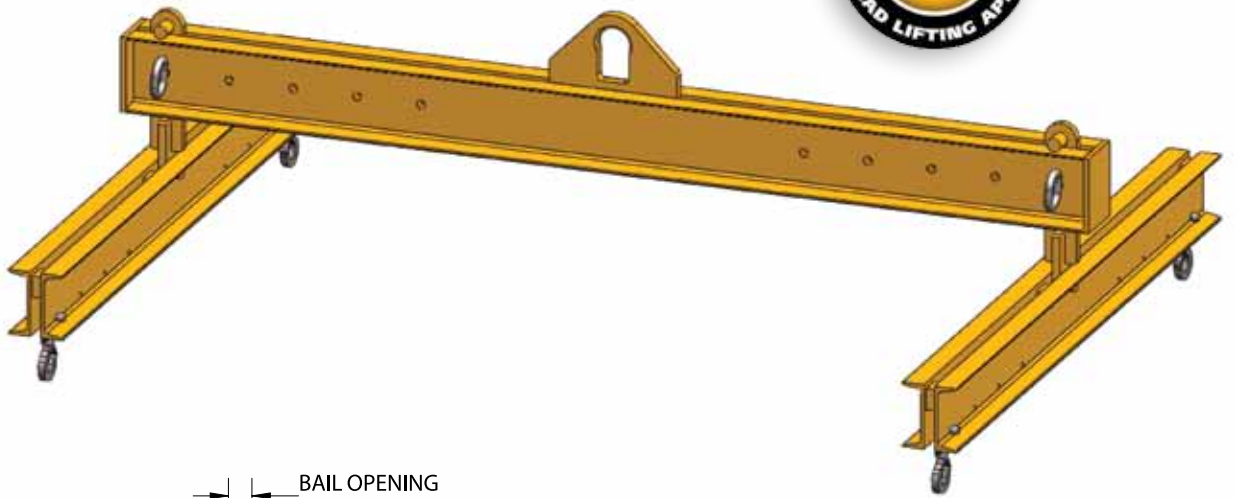

Model #	Capacity (US Tons)*	Main Beam Min/Max Spread	Cross Beam Min/Max Spread	Dimensions (Inches)						Weight (Lbs.)
				Headroom	Bail Height	Bail Opening Width	Bail Opening Height	Bail Thickness	Hook Opening	
FPAB-3-84/60	3	36/84	24/60	28	1.25	3	5	1	0.91	473
FPAB-5-120/96	5	48/120	36/96	33	2	4	7	1.25	1	958
FPAB-10-144/96	10	72/144	36/96	42	2	4	7	1.25	1.36	1928

\* 1 US Ton = 2,000 Lbs



**DO NOT EXCEED CAPACITY!**  
See the SAFETY GUIDELINES section before using these products. Pages 92-95.



## DUAL CRANE ROTATING BEAM

### FEATURES

- This style of lifting beam is designed to be utilized with dual hoists and can rotate the load parallel.
- Designed to meet your specific lifting requirements.
- Engineered and manufactured to ASME B30.20 & BTH-1 Design Category B Service Class 2.
- 100% of ALL Peerless Lifting Beams are Proof-Tested to 125% capacity and certificates supplied at No Additional Charge.



### OPTIONS

- Manual or motorized beam rotation
- Dual hooks
- J-Hooks
- Low headroom bail
- Swivel hooks
- Shackle lugs
- Faspins
- Beam stand

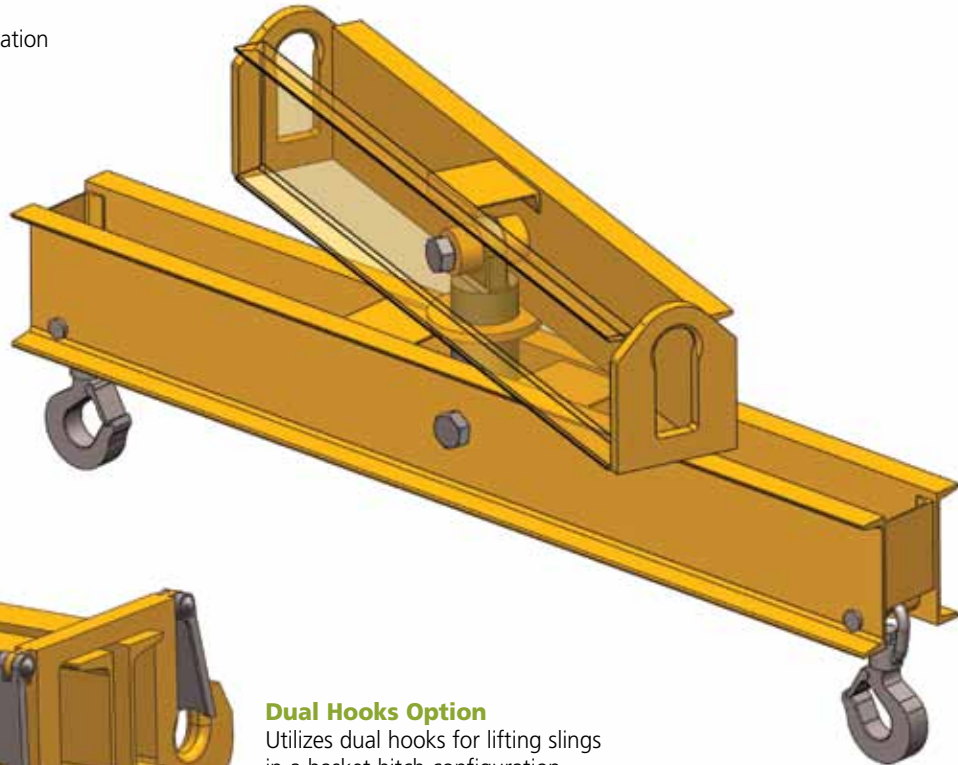

### Dual Hooks Option

Utilizes dual hooks for lifting slings in a basket hitch configuration.

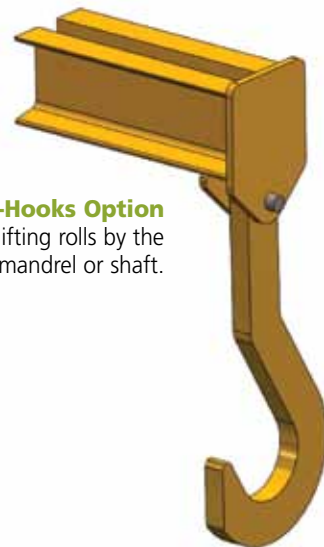
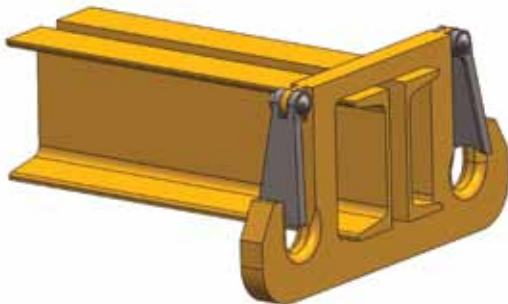

### J-Hooks Option

Utilized when lifting rolls by the mandrel or shaft.

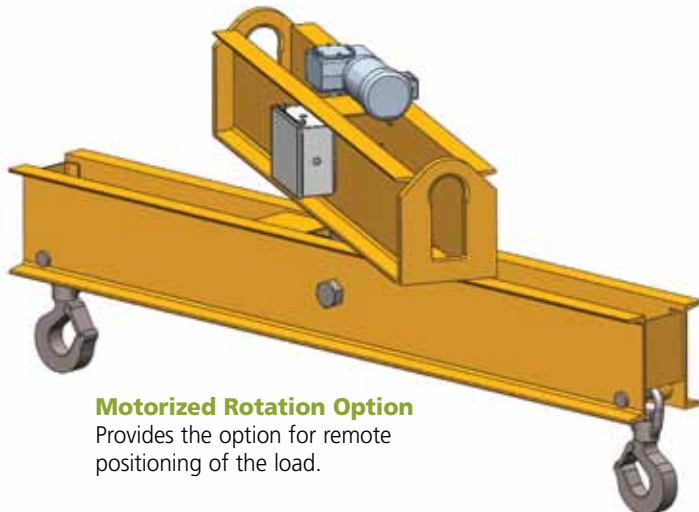

### Motorized Rotation Option

Provides the option for remote positioning of the load.





## CHLORINE GAS CYLINDER LIFTING BEAM

### FEATURES

- This style of lifting beam is designed to lift chlorine gas cylinders.
- Low headroom design.
- Smooth edge design to minimize wear on lifting straps.
- Engineered and manufactured to ASME B30.20 & BTH-1 Design Category B Service Class 2.
- 100% of ALL Peerless Lifting Beams are Proof-Tested to 125% capacity and certificates supplied at No Additional Charge.

### OPTIONS

- Additional sizes are available

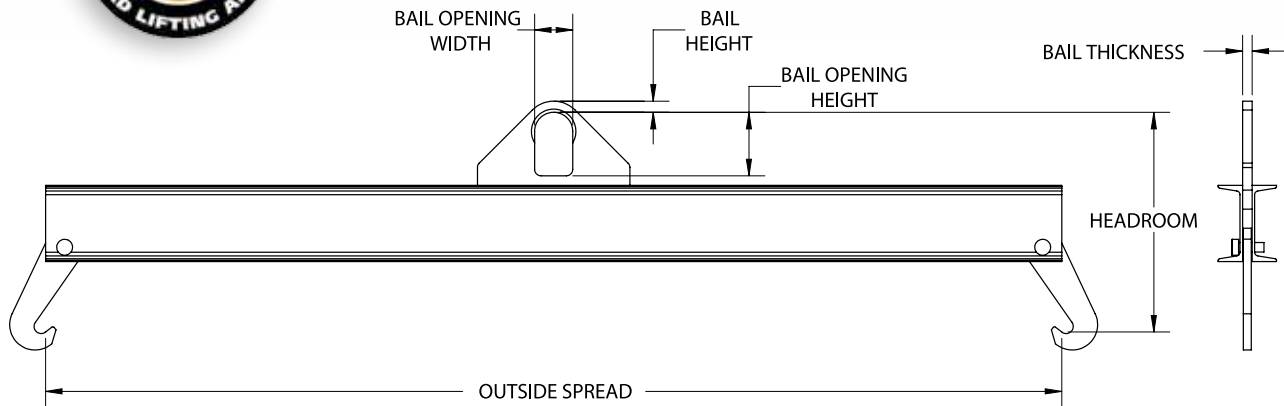
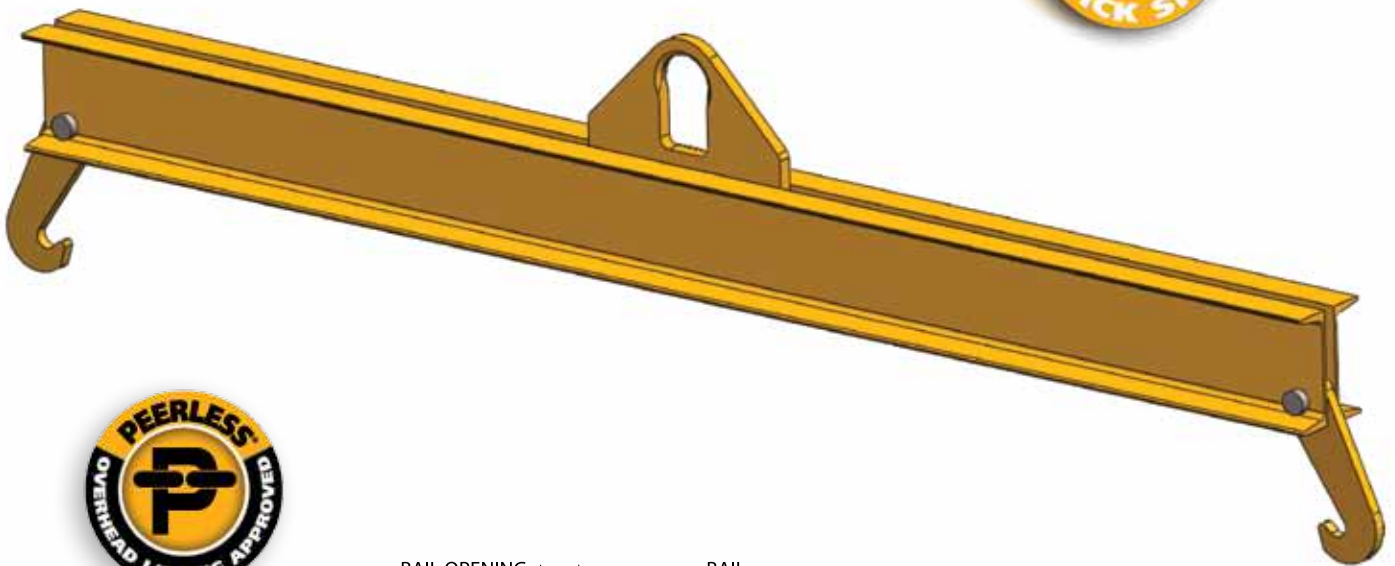

Model #	Capacity (US Tons)*	Dimensions (Inches)						Weight (Lbs.)
		Outside Spread	Headroom	Bail Height	Bail Opening Width	Bail Opening Height	Bail Thickness	
CGCLB-2-80/82	2	80.75 - 82.25	18.5 - 17.5	0.88	3	5	0.75	125

\* 1 US Ton = 2,000 Lbs



**DO NOT EXCEED CAPACITY!**  
See the SAFETY GUIDELINES section before using these products. Pages 92-95.

# LIFTING BEAMS

Custom Application Form



For pricing information: Fax completed form & contact info to (800)-356-1149

## LOAD INFORMATION:

Describe the material you are planning to lift: \_\_\_\_\_

Lifting Beam Stand Required:  Yes  No

Total Number of Lifting Points: \_\_\_\_\_ Spacing Between Points \_\_\_\_\_

Is The CG (center of gravity) Of The Load Between Outer Lifting Points:  
 Yes  No If No, Describe CG Location \_\_\_\_\_

Type Of Rigging Used To Attach To Load: Swivel Hooks Shackles  
Slings (specific type) \_\_\_\_\_ Other (specific type) \_\_\_\_\_

Load Dimensions:

	Min (in)	Max (in)
Height	_____	_____
Width	_____	_____
Length	_____	_____
Weight	_____	_____

## CRANE SPECIFICATIONS:

Crane Configuration:  Single  Double

Distance Between Top Of The Load To The Crane Hook High Position(s): \_\_\_\_\_

Capacity Of The Crane(s): \_\_\_\_\_ Distance Between Cranes (if applicable): \_\_\_\_\_

Required Duty Cycle Of The Lifting Beam: Lifts Per Hour \_\_\_\_\_ Lifts Per Day \_\_\_\_\_

Crane Classification(s):  A  B  C  D  E  F

## DUAL CRANE ROTATING BEAM APPLICATION:

Operation:  Manual  Motorized:  AC  DC Voltage \_\_\_\_\_ Phase \_\_\_\_\_ Cycle \_\_\_\_\_

Controls Required:  Yes  No If Yes: Specify Type \_\_\_\_\_  Furnish Loose  Mounted On Lifter

## CRANE HOOK SPECIFICATIONS (Inches) :

A:\_\_\_ B:\_\_\_ C:\_\_\_ D:\_\_\_ E:\_\_\_ F:\_\_\_ G:\_\_\_ H:\_\_\_

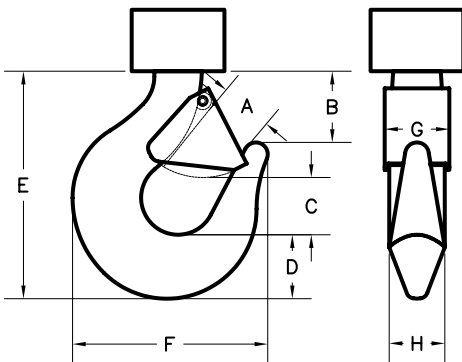

Please provide pertinent application information not supplied above (extreme product or operating temperature, extreme environmental conditions such as temperature or moisture, space or headroom restrictions, additional specifications):

---



---



---



---



---

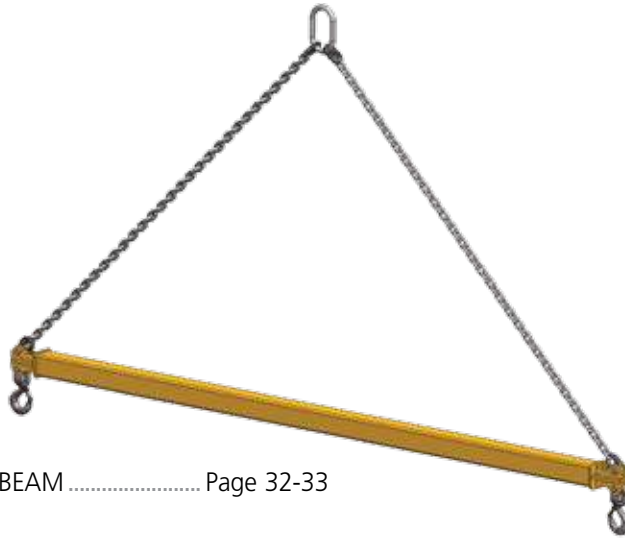

**SDSB**  
STANDARD DUTY SPREADER BEAM ..... Page 32-33

**ATSB**  
ADJUSTABLE TELESCOPIC SPREADER BEAM ..... Page 34



**BXSB**  
BOX SPREADER BEAM ..... Page 35



**ECSB**  
END CAP SPREADER BEAM ..... Page 36-41

# LIFTING EQUIPMENT

## SDSB STANDARD DUTY SPREADER BEAM

SPREADER BEAMS

### FEATURES

- This style of lifter is utilized with upper rigging spread between two lift points that adds extra stability to the lift.
- This spreader beam should be utilized where headroom is not limited and comes standard with a pair of swivel hooks.
- Can be supplied with optional chain or wire rope top rigging.
- Engineered and manufactured to ASME B30.20 & BTH-1 Design Category B Service Class 2.
- 100% of ALL Peerless Spreader Beams are Proof-Tested to 125% capacity and certificates supplied at No Additional Charge.

### OPTIONS

- Higher capacities
- Additional lengths
- Upper and lower shackle design
- Chain top rigging
- Wire rope top rigging

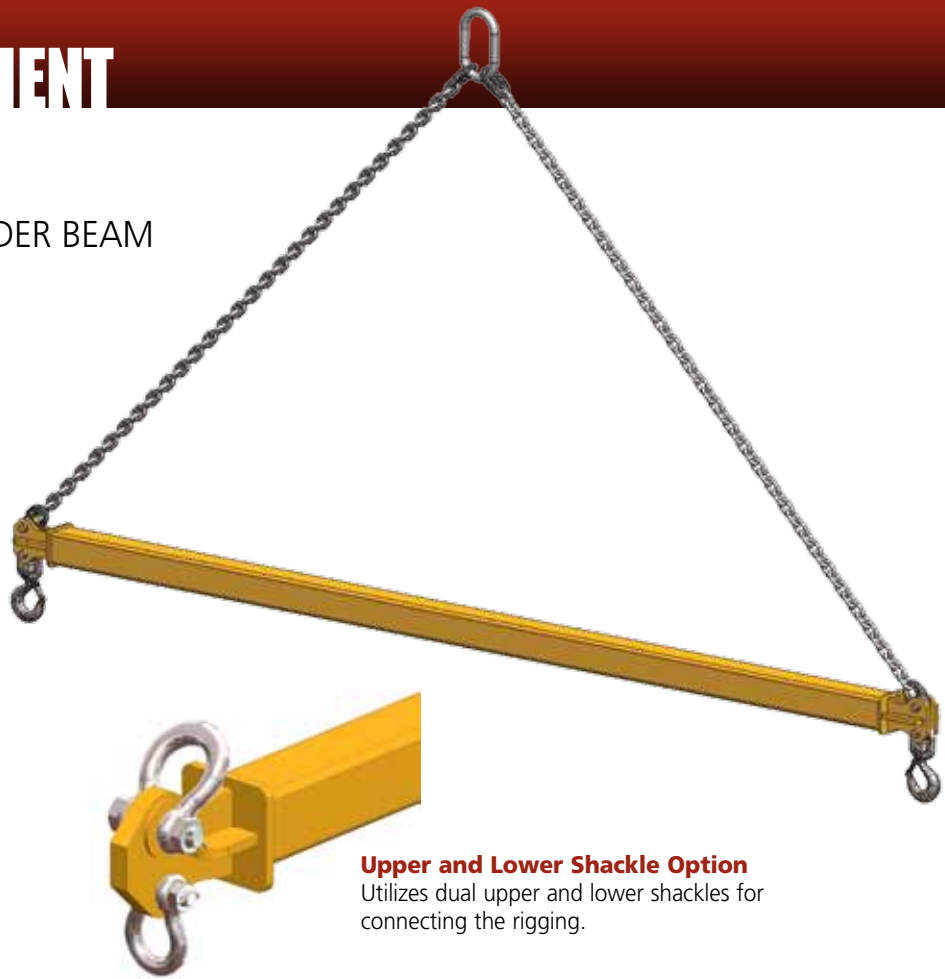

**Upper and Lower Shackle Option**  
Utilizes dual upper and lower shackles for connecting the rigging.

Model #	Capacity (US Tons)*	Outside Spread (Ft.)	Dimensions (Inches)					Weight (Lbs.)
			Headroom	Oblong ML Diameter	Oblong ML Opening Width	Oblong ML Opening Height	Hook Opening	
SDSB-2-4	2	4	36	0.63	3	6	0.91	45
SDSB-2-6	2	6	48	0.63	3	6	0.91	60
SDSB-2-8	2	8	61	0.63	3	6	0.91	82
SDSB-2-10	2	10	74	0.63	3	6	0.91	95
SDSB-2-12	2	12	86	0.63	3	6	0.91	115
SDSB-2-16	2	16	111	0.63	3	6	0.91	225
SDSB-2-20	2	20	139	0.63	3	6	0.91	408
SDSB-2-24	2	24	164	0.63	3	6	0.91	445
SDSB-5-4	5	4	39	1	3.5	7	1.36	62
SDSB-5-6	5	6	51	1	3.5	7	1.36	78
SDSB-5-8	5	8	64	1	3.5	7	1.36	100
SDSB-5-10	5	10	77	1	3.5	7	1.36	117
SDSB-5-12	5	12	87	1	3.5	7	1.36	168
SDSB-5-16	5	16	116	1	3.5	7	1.36	305
SDSB-5-20	5	20	141	1	3.5	7	1.36	435
SDSB-5-24	5	24	166	1	3.5	7	1.36	661
SDSB-10-4	10	4	43	1.25	4.38	8.75	1.61	100
SDSB-10-6	10	6	56	1.25	4.38	8.75	1.61	122
SDSB-10-8	10	8	67	1.25	4.38	8.75	1.61	156
SDSB-10-10	10	10	81	1.25	4.38	8.75	1.61	180
SDSB-10-12	10	12	90	1.25	4.38	8.75	1.61	240
SDSB-10-16	10	16	119	1.25	4.38	8.75	1.61	380
SDSB-10-20	10	20	145	1.25	4.38	8.75	1.61	532
SDSB-10-24	10	24	171	1.25	4.38	8.75	1.61	915
SDSB-15-4	15	4	45	1.5	5.25	10.5	2.08	126
SDSB-15-6	15	6	58	1.5	5.25	10.5	2.08	155

\* 1 US Ton = 2,000 Lbs

cont.



**DO NOT EXCEED CAPACITY!**  
See the SAFETY GUIDELINES section before using these products. Pages 92-95.



# SPREADER BEAMS

SPREADER BEAMS

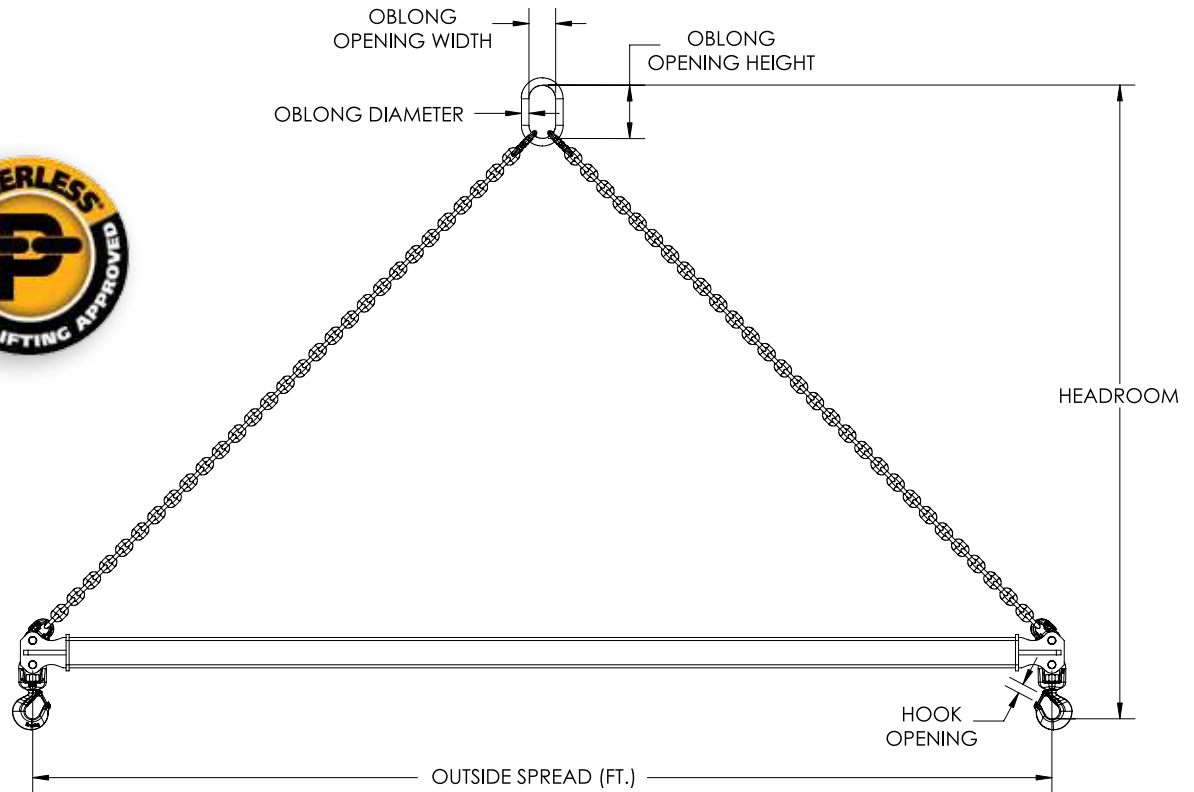

Model #	Capacity (US Tons)*	Outside Spread (Ft.)	Dimensions (Inches)				Weight (Lbs.)	
			Headroom	Oblong ML Diameter	Oblong ML Opening Width	Oblong ML Opening Height		Hook Opening
SDSB-15-8	15	8	68	1.5	5.25	10.5	2.08	185
SDSB-15-10	15	10	84	1.5	5.25	10.5	2.08	242
SDSB-15-12	15	12	97	1.5	5.25	10.5	2.08	270
SDSB-15-16	15	16	122	1.5	5.25	10.5	2.08	420
SDSB-15-20	15	20	147	1.5	5.25	10.5	2.08	665
SDSB-15-24	15	24	175	1.5	5.25	10.5	2.08	953
SDSB-20-4	20	4	48	1.75	6	12	2.27	170
SDSB-20-6	20	6	61	1.75	6	12	2.27	200
SDSB-20-8	20	8	72	1.75	6	12	2.27	233
SDSB-20-10	20	10	86	1.75	6	12	2.27	315
SDSB-20-12	20	12	99	1.75	6	12	2.27	350
SDSB-20-16	20	16	124	1.75	6	12	2.27	540
SDSB-20-20	20	20	147	1.75	6	12	2.27	775
SDSB-20-24	20	24	179	1.75	6	12	2.27	1341
SDSB-30-6	30	6	63	1.75	6	12	2.27	285
SDSB-30-8	30	8	74	1.75	6	12	2.27	402
SDSB-30-10	30	10	87	1.75	6	12	2.27	440
SDSB-30-12	30	12	100	1.75	6	12	2.27	530
SDSB-30-16	30	16	126	1.75	6	12	2.27	888
SDSB-30-20	30	20	152	1.75	6	12	2.27	1390
SDSB-40-6	40	6	68	2	7	14	3.02	563
SDSB-40-8	40	8	81	2	7	14	3.02	695
SDSB-40-10	40	10	93	2	7	14	3.02	781
SDSB-40-12	40	12	107	2	7	14	3.02	1058
SDSB-40-16	40	16	133	2	7	14	3.02	1364

\* 1 US Ton = 2,000 Lbs



**DO NOT EXCEED CAPACITY!**  
See the SAFETY GUIDELINES section before using these products. Pages 92-95.



## ADJUSTABLE TELESCOPIC SPREADER BEAM

SPREADER BEAMS

### FEATURES

- This style of spreader beam is telescopic to accommodate various load sizes – 2 through 15 ton capacities, adjustable increments at 1" and 20 through 40 ton capacities, adjustable increments at 12".
- This style of lifter is utilized with upper rigging spread between two lift points that adds extra stability to the lift.
- This spreader beam should be utilized where headroom is not limited and comes standard with a pair of swivel hooks.
- Can be supplied with optional chain or wire rope top rigging.
- Engineered and manufactured to ASME B30.20 & BTH-1 Design Category B Service Class 2.
- 100% of ALL Peerless Spreader Beams are Proof-Tested to 125% capacity and certificates supplied at No Additional Charge.

### OPTIONS

- Higher capacities
- Additional lengths
- Upper and lower shackle design
- Chain top rigging
- Wire rope top rigging

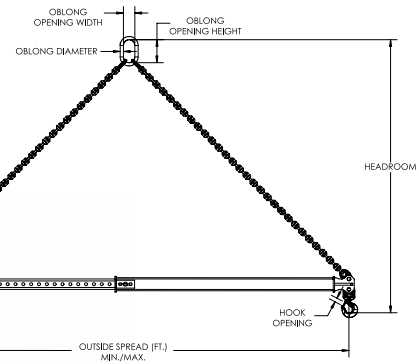
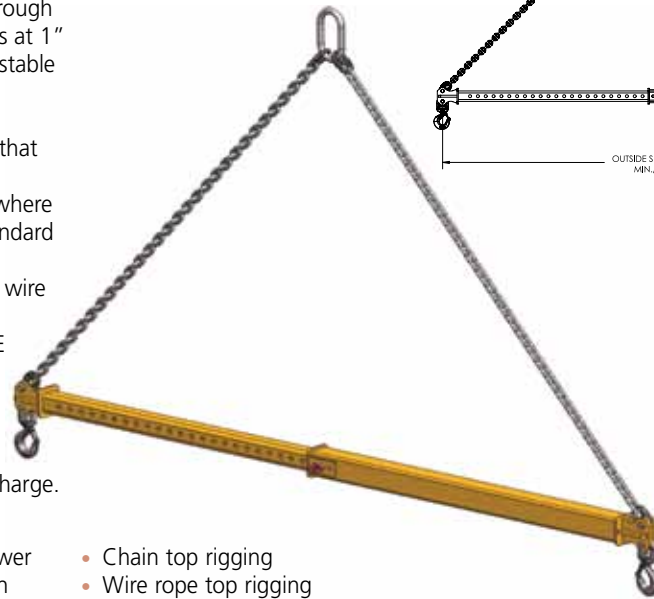

**Upper and Lower Shackle Option**

Utilizes dual upper and lower shackles for connecting the rigging.

Model #	Capacity (US Tons)*	Outside Spread Min/Max (Ft.)	Dimensions (Inches)					Beam & Hook Weight (Lbs.)	Chain Rigging Weight (Lbs.)
			Headroom Min/Max	Oblong ML Diameter	Oblong ML Opening Width	Oblong ML Opening Height	Hook Opening		
ATSB-2-4/6	2	4/6	50/60	0.63	3	6	0.91	70	9
ATSB-2-6/10	2	6/10	76/92	0.63	3	6	0.91	85	13
ATSB-2-8/14	2	8/14	101/119	0.63	3	6	0.91	175	17
ATSB-2-12/20	2	12/20	139/174	0.63	3	6	0.91	245	23
ATSB-5-4/6	5	4/6	58/67	1	3.5	7	1.36	105	34
ATSB-5-6/10	5	6/10	83/100	1	3.5	7	1.36	160	47
ATSB-5-8/14	5	8/14	107/132	1	3.5	7	1.36	205	61
ATSB-5-12/20	5	12/20	145/181	1	3.5	7	1.36	670	82
ATSB-10-4/6	10	4/6	63/72	1.25	4.38	8.75	1.61	95	49
ATSB-10-6/10	10	6/10	78/117	1.25	4.38	8.75	1.61	175	69
ATSB-10-8/14	10	8/14	113/139	1.25	4.38	8.75	1.61	460	88
ATSB-10-12/20	10	12/20	151/171	1.25	4.38	8.75	1.61	680	118
ATSB-15-4/6	15	4/6	67/76	1.5	5.25	10.5	2.08	165	78
ATSB-15-6/10	15	6/10	91/109	1.5	5.25	10.5	2.08	365	111
ATSB-15-8/14	15	8/14	117/142	1.5	5.25	10.5	2.08	478	145
ATSB-15-12/20	15	12/20	154/189	1.5	5.25	10.5	2.08	700	194
ATSB-20-7/11	20	7/11	98/112	1.75	6	12	2.27	430	175
ATSB-20-9/15	20	9/15	129/151	1.75	6	12	2.27	540	225
ATSB-20-12/20	20	12/20	159/189	1.75	6	12	2.27	822	275
ATSB-25-7/11	25	7/11	103/112	2	7	14	3.02	430	240
ATSB-25-9/15	25	9/15	125/148	2	7	14	3.02	540	295
ATSB-25-12/20	25	12/20	156/188	2	7	14	3.02	825	365
ATSB-30-7/11	30	7/11	107/121	2	7	14	3.02	615	240
ATSB-30-9/15	30	9/15	130/152	2	7	14	3.02	750	295
ATSB-30-12/20	30	12/20	162/192	2	7	14	3.02	1065	365
ATSB-40-7/11	40	7/11	110/124	2.25	8	16	3.02	620	375
ATSB-40-9/15	40	9/15	133/155	2.25	8	16	3.02	840	470
ATSB-40-12/20	40	12/20	162/193	2.25	8	16	3.02	1500	565

\* 1 US Ton = 2,000 Lbs



## **BXSB** BOX SPREADER BEAM

### FEATURES

- This style of spreader beam is designed to lift large bulky loads and can be rigged to handle objects with an offset center of gravity.
- Designed to meet your specific lifting requirements and can be manufactured in a welded or bolt together design.
- Product shown is as a bolt-together style with special corner assemblies whereby the shackle lugs can rotate into position in order to prevent side loading.
- If adjustability is required, this style of box spreader beam can be designed with telescopic lengths and/or widths to accommodate various load sizes.
- This spreader beam should be utilized where headroom is not limited.
- This style of lifter is utilized with upper rigging spread between four lift points that adds extra stability to the lift.
- Can be supplied with chain or wire rope top rigging.
- Engineered and manufactured to ASME B30.20 & BTH-1 Design Category B Service Class 2.
- 100% of ALL Peerless Spreader Beams are Proof-Tested to 125% capacity and certificates supplied at No Additional Charge.

### OPTIONS

- Swivel hooks
- Shackles
- Chain slings
- Other special lifting attachments
- Chain top rigging
- Wire rope top rigging



**DO NOT EXCEED CAPACITY!**  
See the SAFETY GUIDELINES section before using these products. Pages 92-95.

# LIFTING EQUIPMENT



## END CAP SPREADER BEAM

SPREADER BEAMS

### FEATURES

- This style of lifter is utilized with upper rigging spread between two lift points that adds extra stability to the lift.
- This spreader beam should be utilized where headroom is not limited and comes standard with upper and lower shackles.
- Standard pivoting lifting lugs provide the flexibility of a 75° to 90° lower rigging angle.
- Can be supplied with optional chain or wire rope top rigging.
- Engineered and manufactured in accordance to ASME B30.20 & BTH-1 Design Category B Service Class 2.
- 100% of ALL Peerless End Cap Spreader Beams are Proof-Tested to 125% capacity and certificates supplied at No Additional Charge.

### OPTIONS

- Higher capacities
- Additional lengths
- Chain top rigging
- Wire rope top rigging

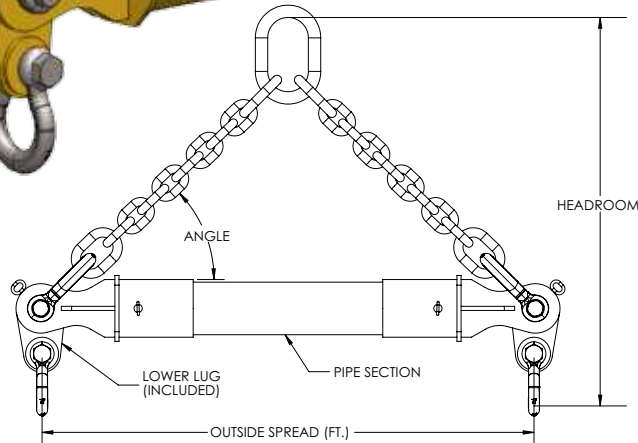

Model #	Capacity (US Tons)*	Outside Spread (Ft.)	End Cap Model #	Pipe Size	Dimensions (Inches)					Top Shackle (Tons)	Bottom Shackle (Tons)	Weight (Lbs)
					Headroom at 45°	Headroom at 60°	Oblong ML Diameter	Oblong ML Opening Width	Oblong ML Opening Height			
ECSB-5-6	5	6	EC-5-25	5" SCH 80	60	86	1	3.5	7	17	13.5	384
ECSB-5-8	5	8	EC-5-25	5" SCH 80	72	106	1	3.5	7	17	13.5	426
ECSB-5-10	5	10	EC-5-25	5" SCH 80	84	128	1	3.5	7	17	13.5	467
ECSB-5-12	5	12	EC-5-25	5" SCH 80	96	148	1	3.5	7	17	13.5	509
ECSB-5-16	5	16	EC-5-25	5" SCH 80	120	192	1	3.5	7	17	13.5	592
ECSB-5-20	5	20	EC-5-25	5" SCH 80	144	232	1	3.5	7	17	13.5	675
ECSB-5-24	5	24	EC-5-25	5" SCH 80	168	274	1	3.5	7	17	13.5	758
ECSB-5-28	5	28	EC-5-25	5" SCH 80	192	316	1	3.5	7	17	13.5	841
ECSB-5-32	5	32	EC-8-50	8" SCH 80	224	364	1	3.5	7	35	25	1753
ECSB-5-36	5	36	EC-8-50	8" SCH 80	248	406	1	3.5	7	35	25	1927
ECSB-5-40	5	40	EC-8-50	8" SCH 80	272	446	1	3.5	7	35	25	2100
ECSB-10-6	10	6	EC-5-25	5" SCH 80	60	86	1.25	4.38	8.75	17	13.5	384
ECSB-10-8	10	8	EC-5-25	5" SCH 80	72	106	1.25	4.38	8.75	17	13.5	426
ECSB-10-10	10	10	EC-5-25	5" SCH 80	84	128	1.25	4.38	8.75	17	13.5	467
ECSB-10-12	10	12	EC-5-25	5" SCH 80	96	148	1.25	4.38	8.75	17	13.5	509
ECSB-10-16	10	16	EC-5-25	5" SCH 80	120	192	1.25	4.38	8.75	17	13.5	592
ECSB-10-20	10	20	EC-5-25	5" SCH 80	144	232	1.25	4.38	8.75	17	13.5	675
ECSB-10-24	10	24	EC-5-25	5" SCH 80	168	274	1.25	4.38	8.75	17	13.5	758
ECSB-10-28	10	28	EC-5-25	5" SCH 80	N/A	316	1.25	4.38	8.75	17	13.5	841
ECSB-10-32	10	32	EC-8-50	8" SCH 80	224	364	1.25	4.38	8.75	35	25	1753
ECSB-10-36	10	36	EC-8-50	8" SCH 80	248	406	1.25	4.38	8.75	35	25	1927
ECSB-10-40	10	40	EC-8-50	8" SCH 80	272	446	1.25	4.38	8.75	35	25	2100

\* 1 US Ton = 2,000 Lbs

cont.



**DO NOT EXCEED CAPACITY!**  
See the SAFETY GUIDELINES section before using these products. Pages 92-95.

## END CAP SPREADER BEAM cont.

Model #	Capacity (US Tons)*	Outside Spread (Ft.)	End Cap Model #	Pipe Size	Dimensions (Inches)					Top Shackle (Tons)	Bottom Shackle (Tons)	Weight (Lbs)
					Head-room at 45°	Head-room at 60°	Oblong ML Diameter	Oblong ML Opening Width	Oblong ML Opening Height			
ECSB-15-6	15	6	EC-5-25	5" SCH 80	60	86	1.5	5.25	10.5	17	13.5	384
ECSB-15-8	15	8	EC-5-25	5" SCH 80	72	106	1.5	5.25	10.5	17	13.5	426
ECSB-15-10	15	10	EC-5-25	5" SCH 80	84	128	1.5	5.25	10.5	17	13.5	467
ECSB-15-12	15	12	EC-5-25	5" SCH 80	96	148	1.5	5.25	10.5	17	13.5	509
ECSB-15-16	15	16	EC-5-25	5" SCH 80	120	192	1.5	5.25	10.5	17	13.5	592
ECSB-15-20	15	20	EC-5-25	5" SCH 80	N/A	232	1.5	5.25	10.5	17	13.5	675
ECSB-15-24	15	24	EC-5-25	5" SCH 80	N/A	274	1.5	5.25	10.5	17	13.5	758
ECSB-15-28	15	28	EC-8-50	8" SCH 80	200	324	1.5	5.25	10.5	35	25	1580
ECSB-15-32	15	32	EC-8-50	8" SCH 80	224	364	1.5	5.25	10.5	35	25	1753
ECSB-15-36	15	36	EC-8-50	8" SCH 80	248	406	1.5	5.25	10.5	35	25	1927
ECSB-15-40	15	40	EC-8-50	8" SCH 80	272	446	1.5	5.25	10.5	35	25	2100
ECSB-20-6	20	6	EC-5-25	5" SCH 80	60	86	1.75	6	12	17	13.5	384
ECSB-20-8	20	8	EC-5-25	5" SCH 80	72	106	1.75	6	12	17	13.5	426
ECSB-20-10	20	10	EC-5-25	5" SCH 80	84	128	1.75	6	12	17	13.5	467
ECSB-20-12	20	12	EC-5-25	5" SCH 80	96	148	1.75	6	12	17	13.5	509
ECSB-20-16	20	16	EC-5-25	5" SCH 80	N/A	192	1.75	6	12	17	13.5	592
ECSB-20-20	20	20	EC-5-25	5" SCH 80	N/A	232	1.75	6	12	17	13.5	675
ECSB-20-24	20	24	EC-8-50	8" SCH 80	176	282	1.75	6	12	35	25	1406
ECSB-20-28	20	28	EC-8-50	8" SCH 80	200	324	1.75	6	12	35	25	1580
ECSB-20-32	20	32	EC-8-50	8" SCH 80	224	364	1.75	6	12	35	25	1753
ECSB-20-36	20	36	EC-8-50	8" SCH 80	N/A	406	1.75	6	12	35	25	1927
ECSB-20-40	20	40	EC-8-50	8" SCH 80	N/A	446	1.75	6	12	35	25	2100
ECSB-25-6	25	6	EC-5-25	5" SCH 80	60	86	1.75	6	12	17	13.5	384
ECSB-25-8	25	8	EC-5-25	5" SCH 80	72	106	1.75	6	12	17	13.5	426
ECSB-25-10	25	10	EC-5-25	5" SCH 80	84	128	1.75	6	12	17	13.5	467
ECSB-25-12	25	12	EC-5-25	5" SCH 80	96	148	1.75	6	12	17	13.5	509
ECSB-25-16	25	16	EC-5-25	5" SCH 80	N/A	192	1.75	6	12	17	13.5	592
ECSB-25-20	25	20	EC-8-50	8" SCH 80	N/A	232	1.75	6	12	35	25	1232
ECSB-25-24	25	24	EC-8-50	8" SCH 80	176	282	1.75	6	12	35	25	1406
ECSB-25-28	25	28	EC-8-50	8" SCH 80	200	324	1.75	6	12	35	25	1580
ECSB-25-32	25	32	EC-8-50	8" SCH 80	224	364	1.75	6	12	35	25	1753
ECSB-25-36	25	36	EC-8-50	8" SCH 80	N/A	406	1.75	6	12	35	25	1927
ECSB-25-40	25	40	EC-8-50	8" SCH 80	N/A	446	1.75	6	12	35	25	2100
ECSB-30-6	30	6	EC-5-50	5" SCH 80	68	94	1.75	6	12	35	25	450
ECSB-30-8	30	8	EC-5-50	5" SCH 80	N/A	114	1.75	6	12	35	25	492
ECSB-30-10	30	10	EC-5-50	5" SCH 80	N/A	136	1.75	6	12	35	25	533
ECSB-30-12	30	12	EC-5-50	5" SCH 80	N/A	156	1.75	6	12	35	25	575
ECSB-30-16	30	16	EC-8-50	8" SCH 80	128	200	1.75	6	12	35	25	1059
ECSB-30-20	30	20	EC-8-50	8" SCH 80	152	240	1.75	6	12	35	25	1232
ECSB-30-24	30	24	EC-8-50	8" SCH 80	176	282	1.75	6	12	35	25	1406
ECSB-30-28	30	28	EC-8-50	8" SCH 80	200	324	1.75	6	12	35	25	1580
ECSB-30-32	30	32	EC-8-50	8" SCH 80	224	364	1.75	6	12	35	25	1753
ECSB-30-36	30	36	EC-8-50	8" SCH 80	N/A	406	1.75	6	12	35	25	1927
ECSB-30-40	30	40	EC-12-80	12" SCH 80	278	452	1.75	6	12	55	55	4184
ECSB-40-6	40	6	EC-5-50	5" SCH 80	N/A	94	2.25	8	16	35	25	450
ECSB-40-8	40	8	EC-5-50	5" SCH 80	N/A	114	2.25	8	16	35	25	492
ECSB-40-10	40	10	EC-8-50	8" SCH 80	92	136	2.25	8	16	35	25	798
ECSB-40-12	40	12	EC-8-50	8" SCH 80	104	156	2.25	8	16	35	25	885
ECSB-40-16	40	16	EC-8-50	8" SCH 80	128	200	2.25	8	16	35	25	1059
ECSB-40-20	40	20	EC-8-50	8" SCH 80	152	240	2.25	8	16	35	25	1232
ECSB-40-24	40	24	EC-8-50	8" SCH 80	176	282	2.25	8	16	35	25	1406
ECSB-40-28	40	28	EC-8-50	8" SCH 80	N/A	324	2.25	8	16	35	25	1580
ECSB-40-32	40	32	EC-8-50	8" SCH 80	N/A	364	2.25	8	16	35	25	1753
ECSB-40-36	40	36	EC-12-80	12" SCH 80	254	412	2.25	8	16	55	55	3830
ECSB-40-40	40	40	EC-12-80	12" SCH 80	278	452	2.25	8	16	55	55	4184

\* 1 US Ton = 2,000 Lbs



**DO NOT EXCEED CAPACITY!**  
See the SAFETY GUIDELINES section before using these products. Pages 92-95.

# LIFTING EQUIPMENT

SPREADER BEAMS



## END CAP SPREADER BEAM cont.



Model #	Capacity (US Tons)*	Outside Spread (Ft.)	End Cap Model #	Pipe Size	Dimensions (Inches)					Top Shackle (Tons)	Bottom Shackle (Tons)	Weight (Lbs)
					Head-room at 45°	Head-room at 60°	Oblong ML Diameter	Oblong ML Opening Width	Oblong ML Opening Height			
ECSB-50-6	50	6	EC-5-50	5" SCH 80	N/A	94	2.25	8	16	35	25	450
ECSB-50-8	50	8	EC-5-50	5" SCH 80	N/A	114	2.25	8	16	35	25	492
ECSB-50-10	50	10	EC-8-50	8" SCH 80	92	136	2.25	8	16	35	25	798
ECSB-50-12	50	12	EC-8-50	8" SCH 80	104	156	2.25	8	16	35	25	885
ECSB-50-16	50	16	EC-8-50	8" SCH 80	128	200	2.25	8	16	35	25	1059
ECSB-50-20	50	20	EC-8-50	8" SCH 80	152	240	2.25	8	16	35	25	1232
ECSB-50-24	50	24	EC-8-50	8" SCH 80	N/A	282	2.25	8	16	35	25	1406
ECSB-50-28	50	28	EC-8-50	8" SCH 80	N/A	324	2.25	8	16	35	25	1580
ECSB-50-32	50	32	EC-8-50	8" SCH 80	N/A	364	2.25	8	16	35	25	1753
ECSB-50-36	50	36	EC-12-80	12" SCH 80	254	412	2.25	8	16	55	55	3830
ECSB-50-40	50	40	EC-12-80	12" SCH 80	278	452	2.25	8	16	55	55	4184
ECSB-60-8	60	8	EC-8-80	8" SCH 80	84	120	2.5	8	16	55	55	896
ECSB-60-10	60	10	EC-8-80	8" SCH 80	96	140	2.5	8	16	55	55	982
ECSB-60-12	60	12	EC-8-80	8" SCH 80	108	162	2.5	8	16	55	55	1069
ECSB-60-16	60	16	EC-8-80	8" SCH 80	132	204	2.5	8	16	55	55	1243
ECSB-60-20	60	20	EC-8-80	8" SCH 80	N/A	246	2.5	8	16	55	55	1416
ECSB-60-24	60	24	EC-8-80	8" SCH 80	N/A	286	2.5	8	16	55	55	1590
ECSB-60-28	60	28	EC-8-80	8" SCH 80	N/A	328	2.5	8	16	55	55	1764
ECSB-60-32	60	32	EC-8-80	8" SCH 80	N/A	370	2.5	8	16	55	55	1937
ECSB-60-36	60	36	EC-12-80	12" SCH 80	254	412	2.5	8	16	55	55	3830
ECSB-60-40	60	40	EC-12-80	12" SCH 80	278	452	2.5	8	16	55	55	4184
ECSB-70-8	70	8	EC-8-80	8" SCH 80	84	120	2.75	9	16	55	55	896
ECSB-70-10	70	10	EC-8-80	8" SCH 80	96	140	2.75	9	16	55	55	982
ECSB-70-12	70	12	EC-8-80	8" SCH 80	N/A	162	2.75	9	16	55	55	1069
ECSB-70-16	70	16	EC-8-80	8" SCH 80	N/A	204	2.75	9	16	55	55	1243
ECSB-70-20	70	20	EC-12-80	12" SCH 80	156	246	2.75	9	16	55	55	2413
ECSB-70-24	70	24	EC-12-80	12" SCH 80	180	286	2.75	9	16	55	55	2769
ECSB-70-28	70	28	EC-12-80	12" SCH 80	204	328	2.75	9	16	55	55	3122
ECSB-70-32	70	32	EC-12-80	12" SCH 80	230	370	2.75	9	16	55	55	3476
ECSB-70-36	70	36	EC-12-80	12" SCH 80	254	412	2.75	9	16	55	55	3830
ECSB-70-40	70	40	EC-12-80	12" SCH 80	278	452	2.75	9	16	55	55	4184
ECSB-80-8	80	8	EC-8-80	8" SCH 80	84	120	3.25	10	20	55	55	896
ECSB-80-10	80	10	EC-8-80	8" SCH 80	N/A	140	3.25	10	20	55	55	982
ECSB-80-12	80	12	EC-8-80	8" SCH 80	N/A	162	3.25	10	20	55	55	1069
ECSB-80-16	80	16	EC-8-80	8" SCH 80	N/A	204	3.25	10	20	55	55	1243
ECSB-80-20	80	20	EC-12-80	12" SCH 80	156	246	3.25	10	20	55	55	2413
ECSB-80-24	80	24	EC-12-80	12" SCH 80	180	286	3.25	10	20	55	55	2768
ECSB-80-28	80	28	EC-12-80	12" SCH 80	204	328	3.25	10	20	55	55	3122
ECSB-80-32	80	32	EC-12-80	12" SCH 80	230	370	3.25	10	20	55	55	3476
ECSB-80-36	80	36	EC-12-80	12" SCH 80	254	412	3.25	10	20	55	55	3830
ECSB-80-40	80	40	EC-12-80	12" SCH 80	278	452	3.25	10	20	55	55	4184

\* 1 US Ton = 2,000 Lbs

cont.



**DO NOT EXCEED CAPACITY!**  
See the SAFETY GUIDELINES section before using these products. Pages 92-95.

## END CAP SPREADER BEAM cont.

Model #	Capacity (US Tons)*	Outside Spread (Ft.)	End Cap Model #	Pipe Size	Dimensions (Inches)					Top Shackle (Tons)	Bottom Shackle (Tons)	Weight (Lbs)
					Head-room at 45°	Head-room at 60°	Oblong ML Diameter	Oblong ML Opening Width	Oblong ML Opening Height			
ECSB-90-8	90	8	EC-12-110	12" SCH 80	84	120	3.25	10	20	85	55	1519
ECSB-90-10	90	10	EC-12-110	12" SCH 80	96	140	3.25	10	20	85	55	1696
ECSB-90-12	90	12	EC-12-110	12" SCH 80	108	162	3.25	10	20	85	55	1873
ECSB-90-16	90	16	EC-12-110	12" SCH 80	132	204	3.25	10	20	85	55	2227
ECSB-90-20	90	20	EC-12-110	12" SCH 80	156	246	3.25	10	20	85	55	2581
ECSB-90-24	90	24	EC-12-110	12" SCH 80	180	286	3.25	10	20	85	55	2936
ECSB-90-28	90	28	EC-12-110	12" SCH 80	204	328	3.25	10	20	85	55	3290
ECSB-90-32	90	32	EC-12-110	12" SCH 80	230	370	3.25	10	20	85	55	3644
ECSB-90-36	90	36	EC-12-110	12" SCH 80	254	412	3.25	10	20	85	55	3998
ECSB-90-40	90	40	EC-12-110	12" SCH 80	N/A	452	3.25	10	20	85	55	4352
ECSB-100-8	100	8	EC-12-110	12" SCH 80	84	120	3.5	10	20	85	55	1519
ECSB-100-10	100	10	EC-12-110	12" SCH 80	96	140	3.5	10	20	85	55	1696
ECSB-100-12	100	12	EC-12-110	12" SCH 80	108	162	3.5	10	20	85	55	1873
ECSB-100-16	100	16	EC-12-110	12" SCH 80	132	204	3.5	10	20	85	55	2227
ECSB-100-20	100	20	EC-12-110	12" SCH 80	156	246	3.5	10	20	85	55	2581
ECSB-100-24	100	24	EC-12-110	12" SCH 80	180	286	3.5	10	20	85	55	2936
ECSB-100-28	100	28	EC-12-110	12" SCH 80	204	328	3.5	10	20	85	55	3290
ECSB-100-32	100	32	EC-12-110	12" SCH 80	230	370	3.5	10	20	85	55	3644
ECSB-100-36	100	36	EC-12-110	12" SCH 80	N/A	412	3.5	10	20	85	55	3998
ECSB-100-40	100	40	EC-12-110	12" SCH 80	N/A	452	3.5	10	20	85	55	4352
ECSB-110-8	110	8	EC-12-110	12" SCH 80	84	120	3.5	10	20	85	55	1519
ECSB-110-10	110	10	EC-12-110	12" SCH 80	96	140	3.5	10	20	85	55	1696
ECSB-110-12	110	12	EC-12-110	12" SCH 80	108	162	3.5	10	20	85	55	1873
ECSB-110-16	110	16	EC-12-110	12" SCH 80	132	204	3.5	10	20	85	55	2227
ECSB-110-20	110	20	EC-12-110	12" SCH 80	156	246	3.5	10	20	85	55	2581
ECSB-110-24	110	24	EC-12-110	12" SCH 80	180	286	3.5	10	20	85	55	2936
ECSB-110-28	110	28	EC-12-110	12" SCH 80	204	328	3.5	10	20	85	55	3290
ECSB-110-32	110	32	EC-12-110	12" SCH 80	N/A	370	3.5	10	20	85	55	3644
ECSB-110-36	110	36	EC-12-110	12" SCH 80	N/A	412	3.5	10	20	85	55	3998
ECSB-110-40	110	40	EC-12-110	12" SCH 80	N/A	452	3.5	10	20	85	55	4352
ECSB-120-8	120	8	EC-12-130	12" SCH 80	96	130	4	10	20	85	85	1539
ECSB-120-10	120	10	EC-12-130	12" SCH 80	108	152	4	10	20	85	85	1716
ECSB-120-12	120	12	EC-12-130	12" SCH 80	120	172	4	10	20	85	85	1893
ECSB-120-16	120	16	EC-12-130	12" SCH 80	144	216	4	10	20	85	85	2247
ECSB-120-20	120	20	EC-12-130	12" SCH 80	168	256	4	10	20	85	85	2601
ECSB-120-24	120	24	EC-12-130	12" SCH 80	192	298	4	10	20	85	85	2956
ECSB-120-28	120	28	EC-12-130	12" SCH 80	N/A	340	4	10	20	85	85	3310
ECSB-120-32	120	32	EC-12-130	12" SCH 80	N/A	380	4	10	20	85	85	3664
ECSB-120-36	120	36	EC-12-130	12" SCH 80	N/A	422	4	10	20	85	85	4018
ECSB-120-40	120	40	EC-12-130	12" SCH 80	N/A	462	4	10	20	85	85	4372
ECSB-130-8	130	8	EC-12-130	12" SCH 80	96	130	4	10	20	85	85	1539
ECSB-130-10	130	10	EC-12-130	12" SCH 80	108	152	4	10	20	85	85	1716
ECSB-130-12	130	12	EC-12-130	12" SCH 80	120	172	4	10	20	85	85	1893
ECSB-130-16	130	16	EC-12-130	12" SCH 80	144	216	4	10	20	85	85	2247
ECSB-130-20	130	20	EC-12-130	12" SCH 80	168	256	4	10	20	85	85	2601
ECSB-130-24	130	24	EC-12-130	12" SCH 80	N/A	298	4	10	20	85	85	2956
ECSB-130-28	130	28	EC-12-130	12" SCH 80	N/A	340	4	10	20	85	85	3310
ECSB-130-32	130	32	EC-12-130	12" SCH 80	N/A	380	4	10	20	85	85	3664
ECSB-130-36	130	36	EC-12-130	12" SCH 80	N/A	422	4	10	20	85	85	4018

\* 1 US Ton = 2,000 Lbs

SPREADER BEAMS



**WARNING**

DO NOT EXCEED CAPACITY!  
See the SAFETY GUIDELINES section before using these products. Pages 92-95.

## EC END CAP

### FEATURES

- This style of lifting component supplied in pairs allows the user to assemble their own spreader beam by incorporating A53 Grade B, schedule 80 pipe along with upper and lower rigging.
- This style of spreader beam when assembled adds extra stability to the lift.
- This style of spreader beam when assembled should be utilized where headroom is not limited.
- Standard pivoting lifting lugs provide the flexibility of a 75° to 90° lower rigging angle.
- Includes standard assembly pins used to attach the End Cap to the A53 Grade B, schedule 80 pipe.
- Can be supplied with optional upper and lower shackles.
- Can be supplied with optional chain or wire rope top rigging.
- Engineered and manufactured in accordance to ASME B30.20 & BTH-1 Design Category B Service Class 2 and complies when assembled per factory specifications.
- 100% of ALL Peerless End Caps are Proof-Tested to 125% capacity and certificates supplied at No Additional Charge.



### OPTIONS

- Higher capacities
- Upper and lower shackles
- Chain top rigging
- Wire rope top rigging

Model #	Dimensions Capacity (US Tons)*			Schedule 80 Pipe Size (In.)	Schedule 80 Wall Thickness (In.)	Weight (Lbs.)
	Max Capacity	Top Shackle	Bottom Shackle			
EC-5-25	25	17	13.5	5	0.375	312
EC-5-50	50	35	25	5	0.375	378
EC-8-50	50	35	25	8	0.500	488
EC-8-80	80	55	55	8	0.500	672
EC-12-80	80	55	55	12	0.687	924
EC-12-110	110	85	55	12	0.687	1092
EC-12-130	130	85	85	12	0.687	1112

\* 1 US Ton = 2,000 Lbs

## ECP END CAP PIPE

### FEATURES

- This style of lifting component, A53 Grade B, schedule 80 pipe, allows the user to assemble their own spreader beam by attaching specified Peerless End Caps along with upper and lower rigging.
- This style of spreader beam when assembled adds extra stability to the lift.
- This style of spreader beam when assembled should be utilized where headroom is not limited.
- Can be supplied with optional End Caps.
- Can be supplied with optional upper and lower shackles.
- Can be supplied with optional chain or wire rope top rigging.
- Complies with ASME B30.20 & BTH-1 Design Category B Service Class 2 when assembled per factory specifications.
- 100% of ALL Peerless End Cap Pipe is certified to the material specification supplied by the pipe manufacturer as well as for the working load limit that is listed in the End Cap Pipe chart when used in conjunction with the specified End Caps at the appropriate rigging angles.

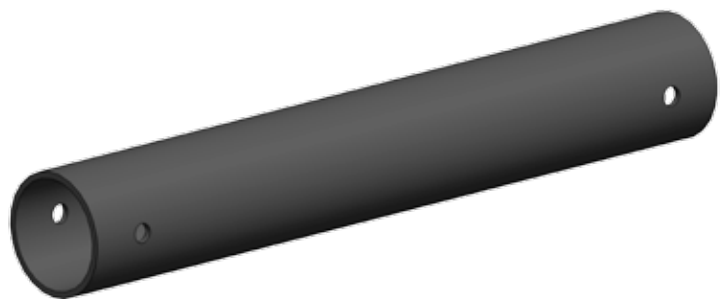

### OPTIONS

- Higher capacities
- Upper and lower shackles
- Chain top rigging
- Wire rope top rigging



## END CAP PIPE cont.

Model #	End Cap Model #	Pipe Size	Outside Spread (Ft.)	Capacity (US Tons)*	Schedule 80 Wall Thickness (In.)	Weight (Lbs)
ECP-5-6	EC-5-25	5" SCH 80	6	25	0.375	72
	EC-5-50	5" SCH 80	6	50	0.375	72
ECP-5-8	EC-5-25	5" SCH 80	8	25	0.375	114
	EC-5-50	5" SCH 80	8	50	0.375	114
ECP-5-10	EC-5-25	5" SCH 80	10	25	0.375	155
	EC-5-50	5" SCH 80	10	30	0.375	155
ECP-5-12	EC-5-25	5" SCH 80	12	25	0.375	197
	EC-5-50	5" SCH 80	12	30	0.375	197
ECP-5-16	EC-5-25	5" SCH 80	16	25	0.375	280
ECP-5-20	EC-5-25	5" SCH 80	20	20	0.375	363
ECP-5-24	EC-5-25	5" SCH 80	24	15	0.375	446
ECP-5-28	EC-5-25	5" SCH 80	28	10	0.375	529
ECP-8-8	EC-8-80	8" SCH 80	8	80	0.500	224
ECP-8-10	EC-8-50	8" SCH 80	10	50	0.500	310
	EC-8-80	8" SCH 80	10	80	0.500	310
ECP-8-12	EC-8-50	8" SCH 80	12	50	0.500	397
	EC-8-80	8" SCH 80	12	80	0.500	397
ECP-8-16	EC-8-50	8" SCH 80	16	50	0.500	571
	EC-8-80	8" SCH 80	16	80	0.500	571
ECP-8-20	EC-8-50	8" SCH 80	20	50	0.500	744
	EC-8-80	8" SCH 80	20	60	0.500	744
ECP-8-24	EC-8-50	8" SCH 80	24	50	0.500	918
	EC-8-80	8" SCH 80	24	60	0.500	918
ECP-8-28	EC-8-50	8" SCH 80	28	50	0.500	1092
	EC-8-80	8" SCH 80	28	60	0.500	1092
ECP-8-32	EC-8-50	8" SCH 80	32	50	0.500	1265
	EC-8-80	8" SCH 80	32	60	0.500	1265
ECP-8-36	EC-8-50	8" SCH 80	36	30	0.500	1439
ECP-8-40	EC-8-50	8" SCH 80	40	25	0.500	1612
ECP-12-8	EC-12-110	12" SCH 80	8	110	0.687	427
	EC-12-130	12" SCH 80	8	130	0.687	427
ECP-12-10	EC-12-110	12" SCH 80	10	110	0.687	604
	EC-12-130	12" SCH 80	10	130	0.687	604
ECP-12-12	EC-12-110	12" SCH 80	12	110	0.687	781
	EC-12-130	12" SCH 80	12	130	0.687	781
ECP-12-16	EC-12-110	12" SCH 80	16	110	0.687	1135
	EC-12-130	12" SCH 80	16	130	0.687	1135
ECP-12-20	EC-12-80	12" SCH 80	20	80	0.687	1489
	EC-12-110	12" SCH 80	20	110	0.687	1489
	EC-12-130	12" SCH 80	20	130	0.687	1489
ECP-12-24	EC-12-80	12" SCH 80	24	80	0.687	1844
	EC-12-110	12" SCH 80	24	110	0.687	1844
	EC-12-130	12" SCH 80	24	130	0.687	1844
ECP-12-28	EC-12-80	12" SCH 80	28	80	0.687	2198
	EC-12-110	12" SCH 80	28	110	0.687	2198
	EC-12-130	12" SCH 80	28	130	0.687	2198
ECP-12-32	EC-12-80	12" SCH 80	32	80	0.687	2552
	EC-12-110	12" SCH 80	32	110	0.687	2552
	EC-12-130	12" SCH 80	32	130	0.687	2552
ECP-12-36	EC-12-80	12" SCH 80	36	80	0.687	2906
	EC-12-110	12" SCH 80	36	110	0.687	2906
	EC-12-130	12" SCH 80	36	130	0.687	2906
ECP-12-40	EC-12-80	12" SCH 80	40	80	0.687	3260
	EC-12-110	12" SCH 80	40	110	0.687	3260
	EC-12-130	12" SCH 80	40	120	0.687	3260

\* 1 US Ton = 2,000 Lbs



**WARNING**

DO NOT EXCEED CAPACITY!  
See the SAFETY GUIDELINES section before using these products. Pages 92-95.



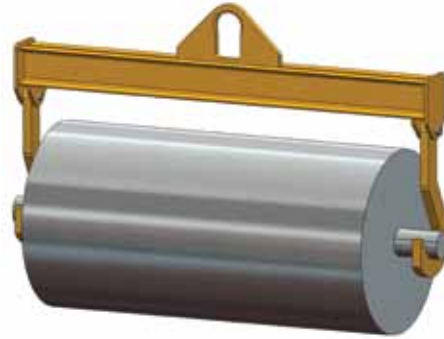

**RLB**  
ROLL LIFTING BEAM..... Page 44

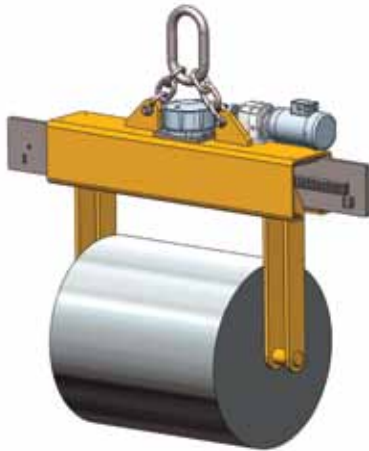

**MRL**  
MOTORIZED ROLL LIFTER..... Page 45

**RGT**  
ROLL GRIPPING TONGS..... Page 46

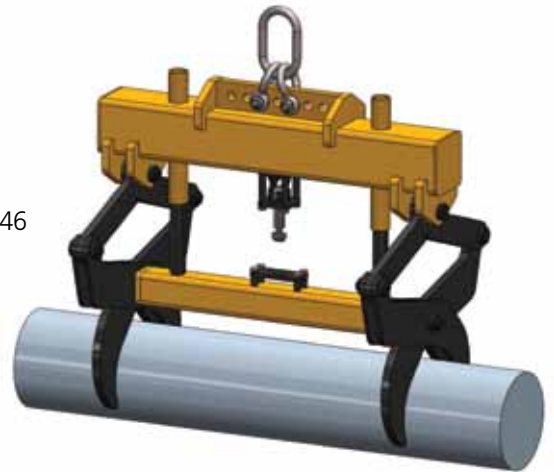

**RLCH**  
ROLL LIFTING C-HOOK..... Page 47



## ROLL LIFTING BEAM

### FEATURES

- This style of lifting beam is designed to easily lift and position rolls by the mandrel/shaft (when it is through the center of the roll) with plate or bent bar J-hooks.
- It can be utilized where headroom is limited and comes with a pair of fixed or pivoting J-hooks.
- Engineered and manufactured to ASME B30.20 & BTH-1 Design Category B Service Class 2.
- 100% of ALL Peerless Roll Lifters are Proof-Tested to 125% capacity and certificates supplied at No Additional Charge.

### OPTIONS

- Manual or motorized beam rotation
- Adjustable spread
- Higher capacities
- Additional lengths
- Low headroom bail
- Dual bail designed for two hoists
- Spreader beam design with top rigging
- Additional hooks
- Hook linings (bronze/brass, urethane, brake lining)
- Beam stand

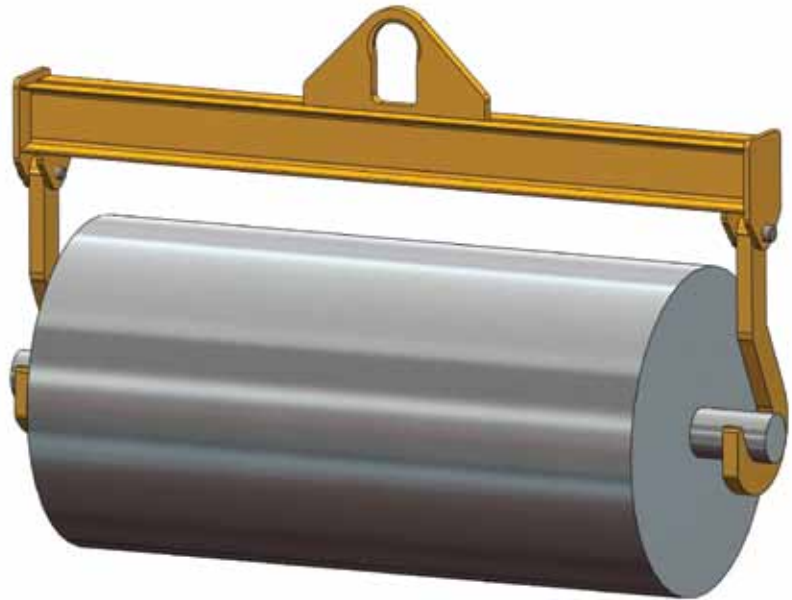

ROLL LIFTERS



#### Adjustable Spread Option

Allows the lifter to handle rolls of varying widths.



#### Hook Lining Option

Utilizes bronze, brass, urethane, or brake linings to provide additional protection to the mandrel or shaft.

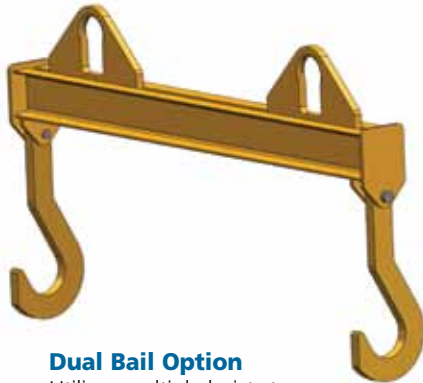

#### Dual Bail Option

Utilizes multiple hoists to add stability to the lift.

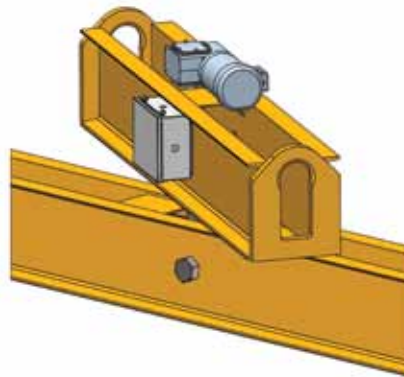

#### Motorized Rotation Option

Provides the option for remote positioning of the load.



#### Spreader Beam Design Option

Provides greater stability when headroom is not limited.





## MOTORIZED ROLL LIFTER

### FEATURES

- This style of lifter is designed to easily lift and position rolls by placing the lifting pins securely through the I.D. of the roll.
- Designed to meet your specific roll lifting requirements.
- Utilizes a sling style bail that adds stability and provides for ease of maintenance on the gearbox and shaft assembly.
- Can be utilized for a variety of roll widths where aisle clearance is limited.
- Manual chain wheel operation is available.
- Engineered and manufactured to ASME B30.20 & BTH-1 Design Category B Service Class 2.
- 100% of ALL Peerless Roll Lifters are Proof-Tested to 125% capacity and certificates supplied at No Additional Charge.

### OPTIONS

- Parking and/or maintenance stands available

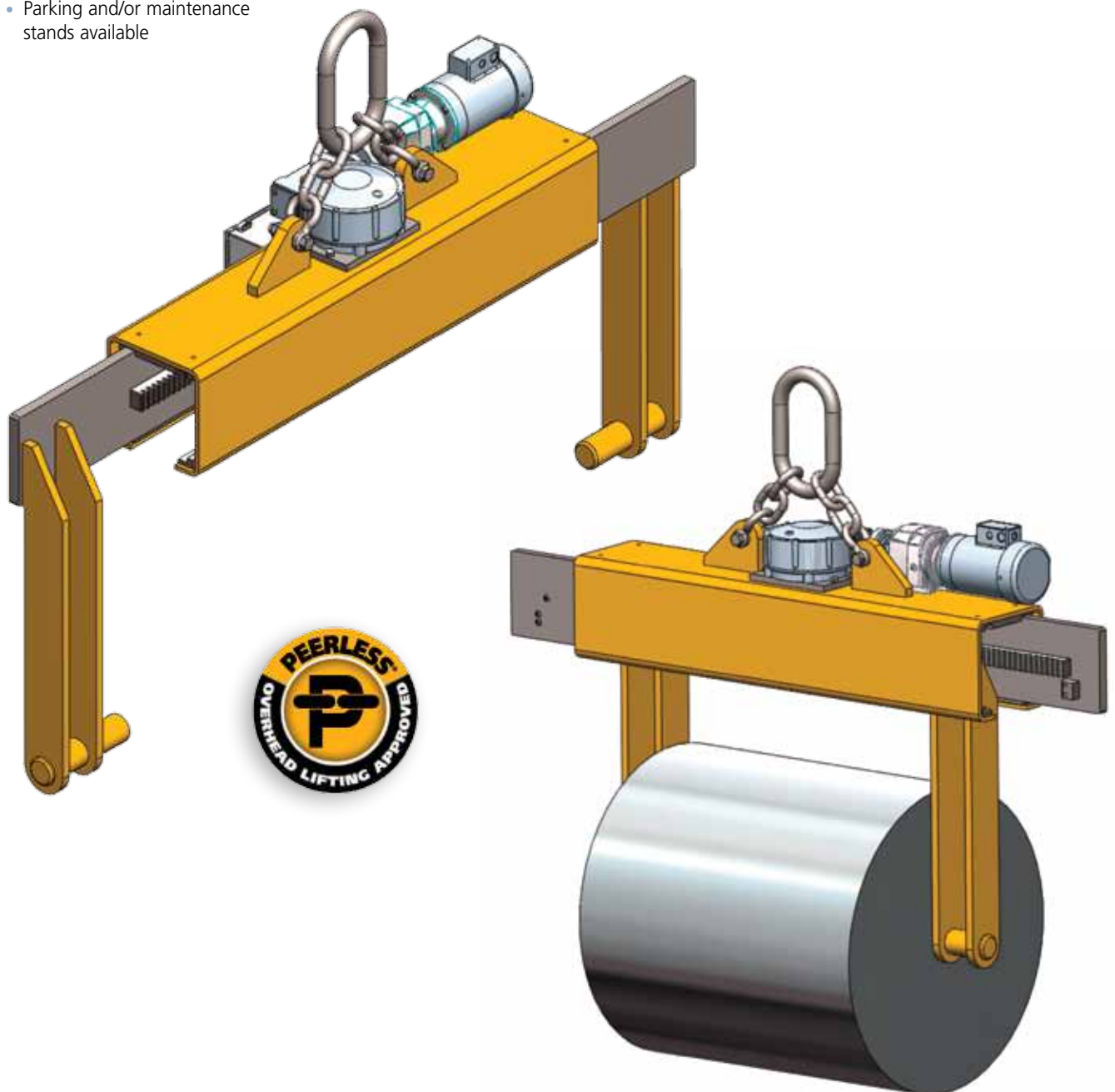

ROLL LIFTERS



**DO NOT EXCEED CAPACITY!**  
See the SAFETY GUIDELINES section before using these products. Pages 92-95.



## ROLL GRIPPING TONGS

### FEATURES

- This style of lifter is designed to easily lift and position rolls by gripping the outer diameter of the roll.
- Designed to meet your specific roll lifting requirements.
- Can be utilized for a variety of roll widths where aisle clearance is limited.
- Auto-latching mechanism supplied for easy one-person operation.
- Protective linings are available to minimize roll damage.
- Engineered and manufactured to ASME B30.20 & BTH-1 Design Category B Service Class 2.
- 100% of ALL Peerless Roll Gripping Tongs are Proof-Tested to 125% capacity and certificates supplied at No Additional Charge.

### OPTIONS

- Parking and/or maintenance stands available

ROLL LIFTERS

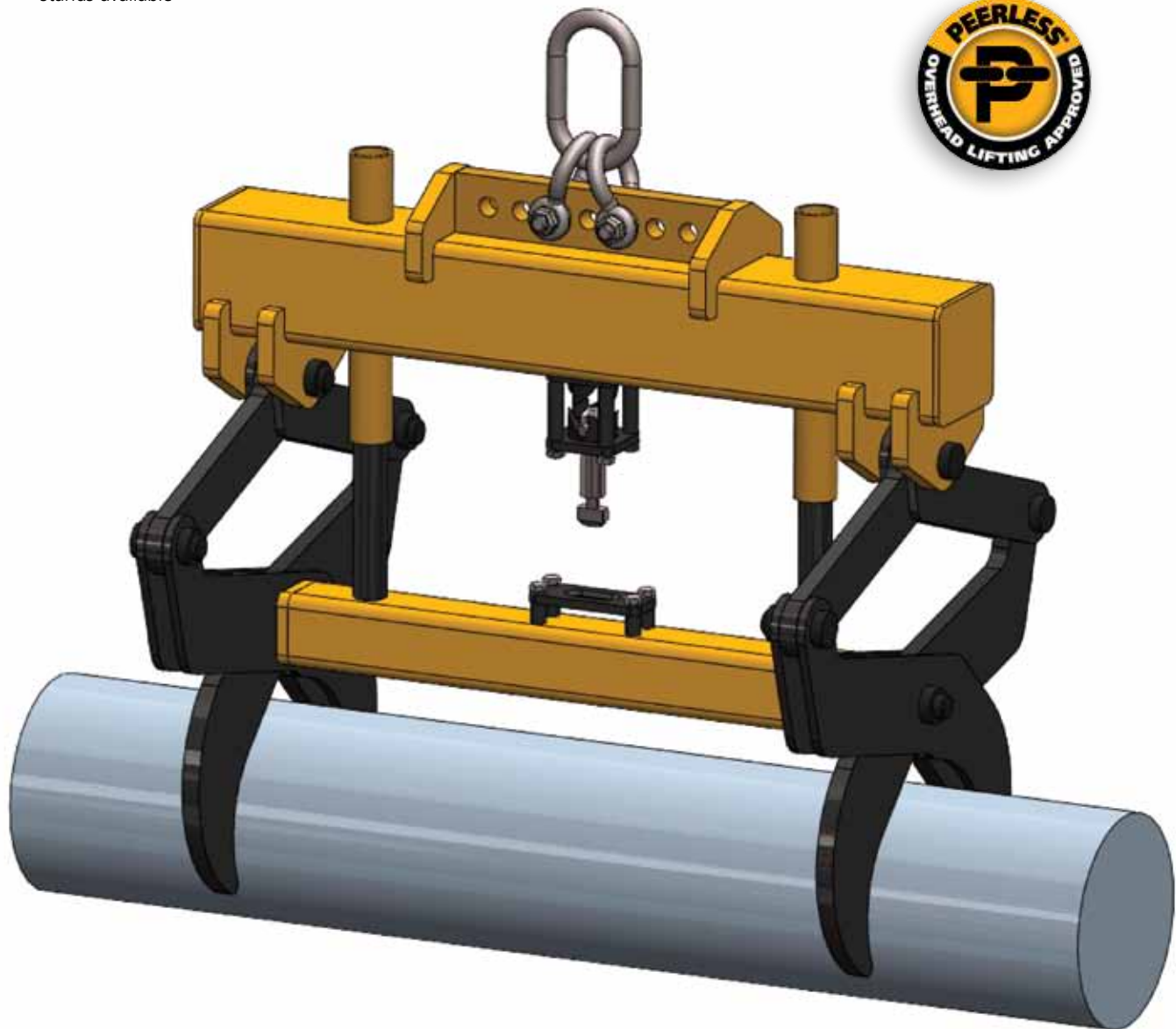

## RLCH ROLL LIFTING C-HOOK

### FEATURES

- This style of lifter is designed to easily lift and position rolls by placing the lifting arm securely through the I.D. of the roll.
- Supplied standard with lifter guide handle.
- Engineered and manufactured to ASME B30.20 & BTH-1 Design Category B Service Class 2.
- 100% of ALL Peerless Roll Lifters are Proof-Tested to 125% capacity and certificates supplied at No Additional Charge.

### OPTIONS

- Higher capacities
- Additional lengths
- Larger throat opening
- Protective padding
- Parking stands



**DO NOT EXCEED CAPACITY!**  
See the SAFETY GUIDELINES section before using these products. Pages 92-95.

# ROLL LIFTER

Custom Application Form



# PEERLESS®

A KITO GROUP COMPANY

For pricing information: Fax completed form & contact info to (800)-356-1149

## LOAD INFORMATION:

Describe the material you are planning to lift: \_\_\_\_\_

Roll Lifter Stand Required:  Yes  No

Is The CG (center of gravity) Of The Load Between Outer Lifting Points:  
 Yes  No If No, Describe CG Location \_\_\_\_\_

Will Roll Be Lifted With A Mandrel Or Shaft:  Yes  No  
If Yes: Mandrel/Shaft Dimensions (inches)  
Min Diameter \_\_\_\_\_ Length \_\_\_\_\_ Max Diameter \_\_\_\_\_ Length \_\_\_\_\_

Will Mandrel/Shaft Turn During Lift:  Yes  No

Mandrel/Shaft Hook Type: Plate Bent Bar Pivoting Fixed

Do Hooks Require Protective Lining:  Yes  No  
If Yes:  Brass  Bronze  Urethane  Brake  Other (specify) \_\_\_\_\_  
If No, Roll I.D. Dimensions (inches): Min Diameter \_\_\_\_\_ Length \_\_\_\_\_ Max Diameter \_\_\_\_\_ Length \_\_\_\_\_

## Bundled Load Dimensions:

	Min (in)	Max (in)
O.D.		
I.D.		
Length		
Weight		

## CRANE SPECIFICATIONS:

Crane Configuration:  Single  Double

Distance Between Top Of The Load To The Crane Hook High Position(s): \_\_\_\_\_

Capacity Of The Crane(s): \_\_\_\_\_ Distance Between Cranes (if applicable): \_\_\_\_\_  
Required Duty Cycle Of The Roll Lifter: Lifts Per Hour \_\_\_\_\_ Lifts Per Day \_\_\_\_\_

Crane Classification(s):  A  B  C  D  E  F

## MOTORIZED ROLL LIFTER APPLICATION:

Operation:  Manual  Motorized:  AC  DC Voltage \_\_\_\_\_ Phase \_\_\_\_\_ Cycle \_\_\_\_\_

Controls Required:  Yes  No If Yes: Specify Type \_\_\_\_\_  Furnish Loose  Mounted On Lifter

## CRANE HOOK SPECIFICATIONS (Inches) :

A: \_\_\_\_\_ B: \_\_\_\_\_ C: \_\_\_\_\_ D: \_\_\_\_\_ E: \_\_\_\_\_ F: \_\_\_\_\_ G: \_\_\_\_\_ H: \_\_\_\_\_

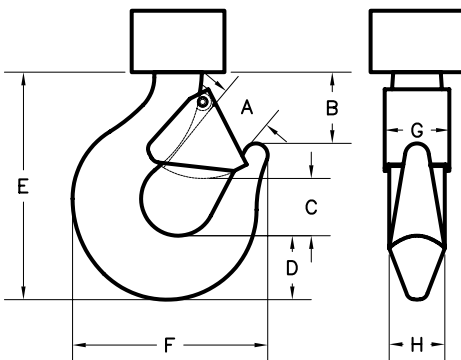

Please provide pertinent application information not supplied above (extreme product or operating temperature, extreme environmental conditions such as temperature or moisture, space or headroom restrictions, additional specifications):

\_\_\_\_\_  
\_\_\_\_\_  
\_\_\_\_\_



## CLNC

COIL LIFTER NARROW COIL .....Page 50



## CL

COIL LIFTER.....Page 51



## CLCS

COIL LIFTER CLOSE STACKING.....Page 52



## CLSC

COIL LIFTER SLIT COIL.....Page 53

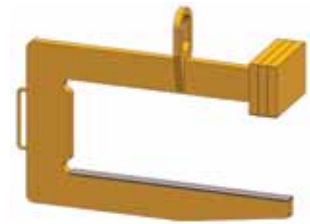

## CLV

COIL LIFTER VERTICAL .....Page 54



## CLVW

COIL LIFTER VERTICAL WIDE .....Page 55



## CGV

COIL GRAB VERTICAL.....Page 56



## CLT

COIL LIFTER TELESCOPIC TWO-SIDED .....Page 57

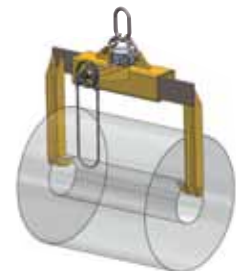

## NACL

NARROW ARM COIL LIFTER .....Page 58





## COIL LIFTER NARROW COIL

### FEATURES

- This style of lifter is designed to easily lift and position narrow coils by placing the lifting arm securely through the I.D. of the coil.
- Supplied with standard lifter guide handle and radius on lifting arm to minimize coil damage.
- Engineered and manufactured to ASME B30.20 & BTH-1 Design Category B Service Class 2.
- 100% of ALL Peerless Coil Lifters are Proof-Tested to 125% capacity and certificates supplied at No Additional Charge.

### OPTIONS

- Higher capacities
- Additional lengths
- Larger throat opening
- Protective padding
- Coil retainer cap
- Parking stands

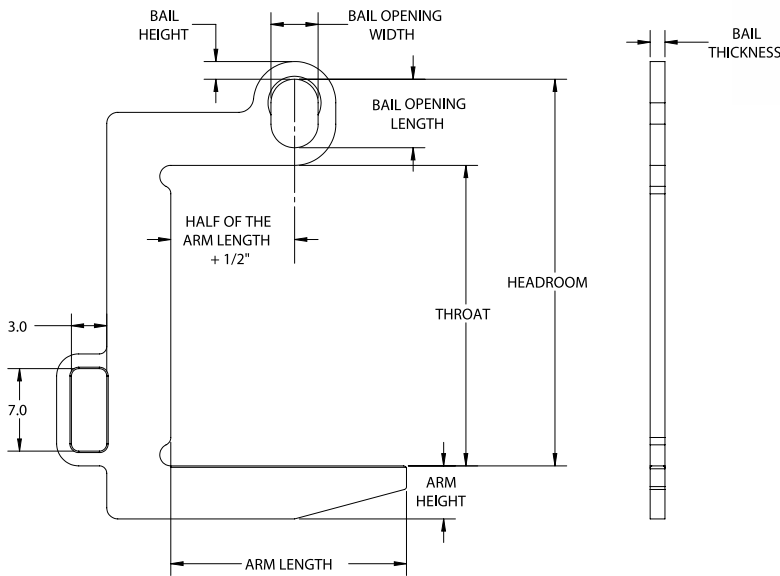

Model #	Capacity (US Tons)*	Dimensions (Inches)									Weight (Lbs.)
		Coil Width Max	Headroom	Lift Arm Length	Lift Arm Height	Throat Opening Height	Bail Height	Bail Opening Width	Bail Opening Height	Bail Thickness	
CLNC-1/2-8	1/2	8	18.6	8	2.25	14.5	0.75	2	3.25	0.5	13
CLNC-1/2-12	1/2	12	18.6	12	2.25	14.5	0.75	2	3.25	0.5	14
CLNC-1-8	1	8	21.6	8	2.25	17.5	0.81	2	3.25	0.5	15
CLNC-1-16	1	16	21.6	16	3	17.5	0.81	2	3.25	0.5	22
CLNC-2-8	2	8	24.5	8	2.5	19.5	1	2.63	4	0.75	27
CLNC-2-16	2	16	24.5	16	3.25	19.5	1	2.63	4	0.75	41
CLNC-3.5-12	3.5	12	28.2	12	3.25	21.5	1.19	3.63	5.5	1	57
CLNC-3.5-16	3.5	16	28.2	16	3.75	21.5	1.19	3.63	5.5	1	69
CLNC-5-16	5	16	33	16	4	25.5	1.5	4	6	1.25	105
CLNC-5-20	5	20	33	20	4.5	25.5	1.5	4	6	1.25	121

\* 1 US Ton = 2,000 Lbs



**DO NOT EXCEED CAPACITY!**  
See the SAFETY GUIDELINES section before using these products. Pages 92-95.



### FEATURES

- This style of heavy duty lifter is designed to easily lift and position large heavy coils by placing the lifting arm securely through the I.D. of the coil.
- Supplied with standard lifter guide handle and curved saddle on lifting arm to minimize coil damage, optional padding is available for additional coil protection.
- Counterbalanced to hang level when not loaded.
- Engineered and manufactured to ASME B30.20 & BTH-1 Design Category B Service Class 2.
- 100% of ALL Peerless Coil Lifters are Proof-Tested to 125% capacity and certificates supplied at No Additional Charge.

### OPTIONS

- Higher capacities
- Additional lengths
- Larger throat opening
- Protective padding
- Parking stands

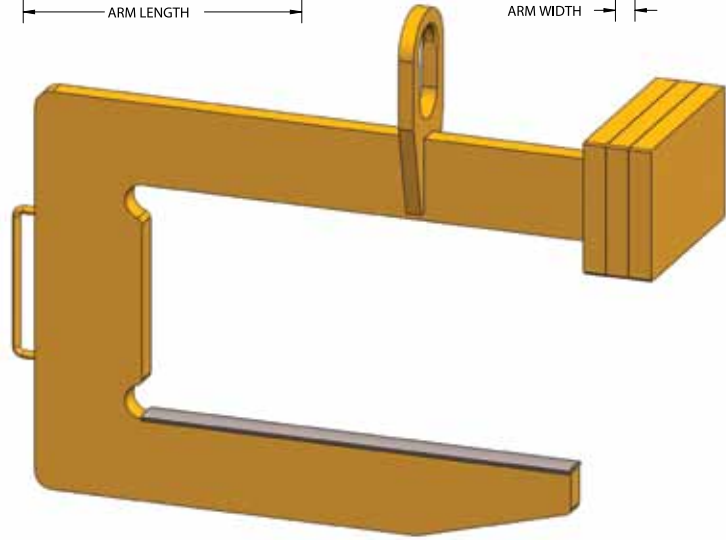
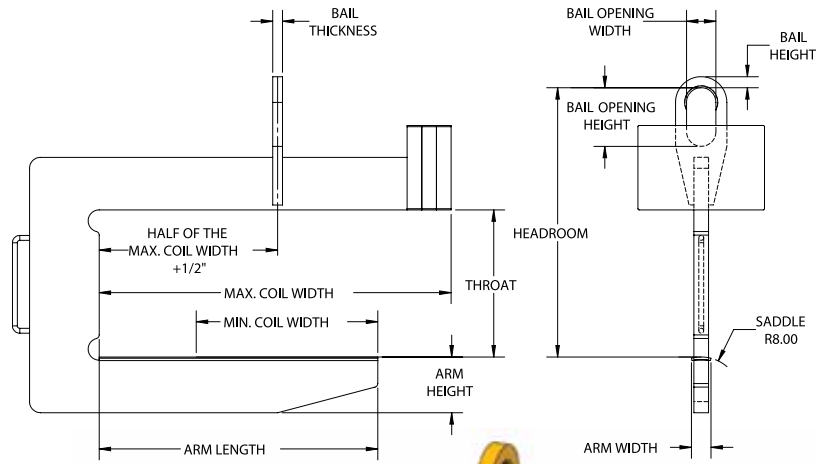

Model #	Capacity (US Tons)*	Coil Width Max/Min	Dimensions (Inches)									Weight (Lbs.)
			Headroom	Lift Arm Length	Lift Arm Height	Lift Arm Width	Throat Opening Height	Bail Height	Bail Opening Width	Bail Opening Height	Bail Thickness	
CL-5-36	5	36/24	38	30	6.25	4	24	1.5	4	7	1.25	500
CL-5-48	5	48/30	38	39	6.25	4	24	1.5	4	7	1.25	730
CL-5-60	5	60/36	38.8	48	7	4	24	1.5	4	7	1.25	885
CL-7.5-36	7.5	36/24	38.3	30	6.5	4	24	1.5	4	7	1.5	725
CL-7.5-48	7.5	48/30	39	39	7.25	4	24	1.5	4	7	1.5	875
CL-7.5-60	7.5	60/36	39.8	48	8	4	24	1.5	4	7	1.5	1060
CL-10-48	10	48/30	42.5	39	8.25	4	24	2	5	9	1.75	1060
CL-10-60	10	60/36	42.5	48	8.25	4	24	2	5	9	1.75	1425
CL-10-72	10	72/42	43.3	57	9	4	24	2	5	9	1.75	1670
CL-15-48	15	48/30	49.3	39	9	4	30	2	5	9	1.75	1615
CL-15-60	15	60/36	50.3	48	10	4	30	2	5	9	1.75	1925
CL-15-72	15	72/42	51	57	10.75	4	30	2	5	9	1.75	2220
CL-20-60	20	60/36	54	48	10.5	4	30	2.25	6	12	2	2520
CL-20-72	20	72/42	55	57	11.5	4	30	2.25	6	12	2	2950
CL-25-60	25	60/36	61.5	48	11.75	4	34	2.5	6	14	2.25	3060
CL-25-72	25	72/42	62.5	57	12.75	4	34	2.5	6	14	2.25	3525
CL-30-60	30	60/36	62.75	48	12.75	4	34	2.75	6	14	2.5	3425
CL-30-72	30	72/42	62	57	12	5	34	2.75	6	14	2.5	4525
CL-40-72	40	72/42	72.3	57	13.75	5	38	3.25	7	18	3	5730
CL-50-84	50	84/48	77.5	66	16.5	5	40	3.75	7	18	3	7550

\* 1 US Ton = 2,000 Lbs



**DO NOT EXCEED CAPACITY!**  
See the SAFETY GUIDELINES section before using these products. Pages 92-95.



## COIL LIFTER CLOSE STACKING

### FEATURES

- This style of heavy duty lifter is designed with a recessed counterweight to allow for close coil stacking that maximizes floor space.
- Designed to easily lift and position large heavy coils by placing the lifting arm securely through the I.D. of the coil.
- Supplied with standard lifter guide handle and curved saddle on lifting arm to minimize coil damage, optional padding is available for additional coil protection.
- Counterbalanced to hang level when not loaded.
- Engineered and manufactured to ASME B30.20 & BTH-1 Design Category B Service Class 2.
- 100% of ALL Peerless Coil Lifters are Proof-Tested to 125% capacity and certificates supplied at No Additional Charge.

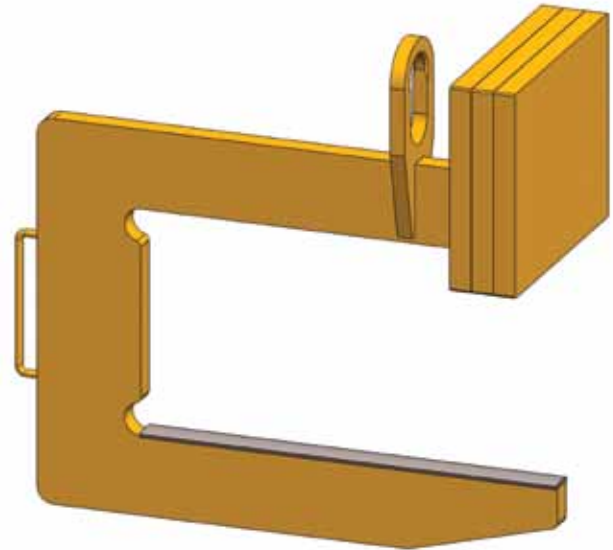

COIL LIFTERS

### OPTIONS

- Higher capacities
- Additional lengths
- Larger throat opening
- Protective padding
- Parking stands

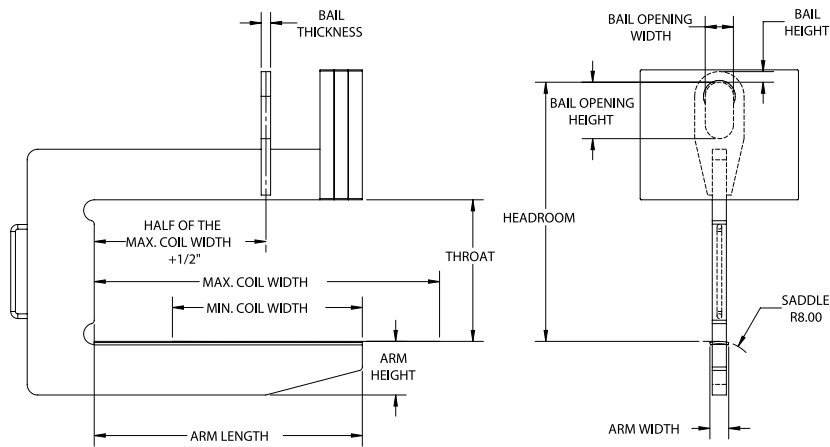

Model #	Capacity (US Tons)**	Dimensions (Inches)										Weight (Lbs.)
		Coil Width Max/Min	Head-room	Lift Arm Length	Lift Arm Height	Lift Arm Width	Throat Opening Height	Bail Height	Bail Opening Width	Bail Opening Height	Bail Thickness	
CLCS-5-36	5	36/24	38	30	6.25	4	24	1.5	4	7	1.25	633
CLCS-5-48	5	48/30	38	39	6.25	4	24	1.5	4	7	1.25	950
CLCS-5-60	5	60/36	38.8	48	7	4	24	1.5	4	7	1.25	1150
CLCS-7.5-36	7.5	36/24	38.3	30	6.5	4	24	1.5	4	7	1.5	950
CLCS-7.5-48	7.5	48/30	39	39	7.25	4	24	1.5	4	7	1.5	1150
CLCS-7.5-60	7.5	60/36	39.8	48	8	4	24	1.5	4	7	1.5	1385
CLCS-10-48	10	48/30	42.5	39	8.25	4	24	2	5	9	1.75	1390
CLCS-10-60	10	60/36	42.5	48	8.25	4	24	2	5	9	1.75	1905
CLCS-10-72	10	72/42	43.3	57	9	4	24	2	5	9	1.75	2210
CLCS-15-48	15	48/30	49.3	39	9	4	30	2	5	9	1.75	2210
CLCS-15-60	15	60/36	50.3	48	10	4	30	2	5	9	1.75	2610
CLCS-15-72	15	72/42	51	57	10.75	4	30	2	5	9	1.75	2990
CLCS-20-60	20	60/36	54	48	10.5	4	30	2.25	6	12	2	3490
CLCS-20-72	20	72/42	55	57	11.5	4	30	2.25	6	12	2	4045
*CLCS-25-60	25	60/36	61.5	48	11.75	4	34	2.5	6	14	2.25	3620
*CLCS-25-72	25	72/42	62.5	57	12.75	4	34	2.5	6	14	2.25	4250
*CLCS-30-60	30	60/36	62.75	48	12.75	4	34	2.75	6	14	2.5	4060
*CLCS-30-72	30	72/42	62	57	12	5	34	2.75	6	14	2.5	5360
*CLCS-40-72	40	72/42	72.3	57	13.75	5	38	3.25	7	18	3	6805

\*Counterweight extends beyond the arm by one-half of the counterweight width (thickness). \*\*1 US Ton = 2,000 Lbs



**DO NOT EXCEED CAPACITY!**  
See the SAFETY GUIDELINES section before using these products. Pages 92-95.



## CLSC COIL LIFTER SLIT COIL

### FEATURES

- This style of heavy duty lifter is designed to handle multiple slit coils maximizing efficiency.
- Designed to easily lift and position large heavy slit coils by placing the lifting arm securely through the I.D. of the coil.
- Supplied with standard lifter guide handle and curved saddle on lifting arm to minimize coil damage, optional padding is available for additional coil protection.
- Counterbalanced to hang level when not loaded.
- Engineered and manufactured to ASME B30.20 & BTH-1 Design Category B Service Class 2.
- 100% of ALL Peerless Coil Lifters are Proof-Tested to 125% capacity and certificates supplied at No Additional Charge.

### OPTIONS

- Higher capacities
- Additional lengths
- Larger throat opening
- Protective padding
- Parking stands

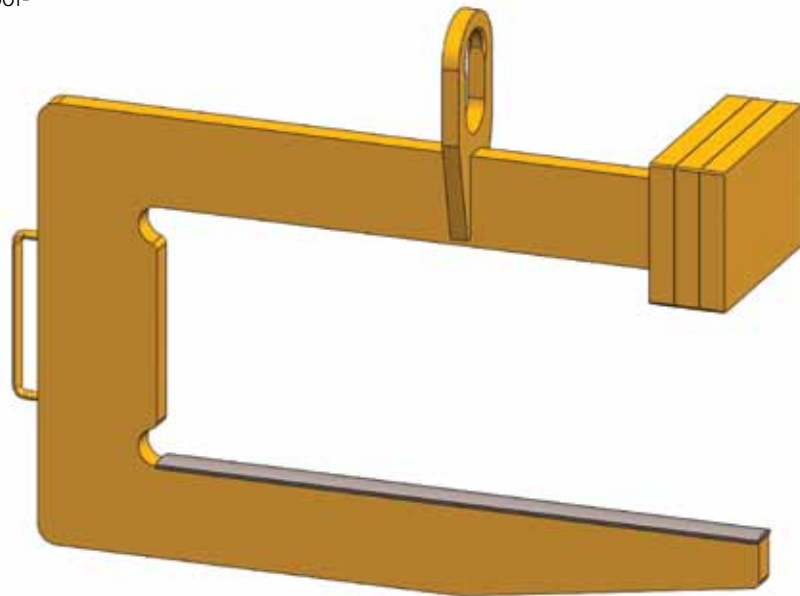
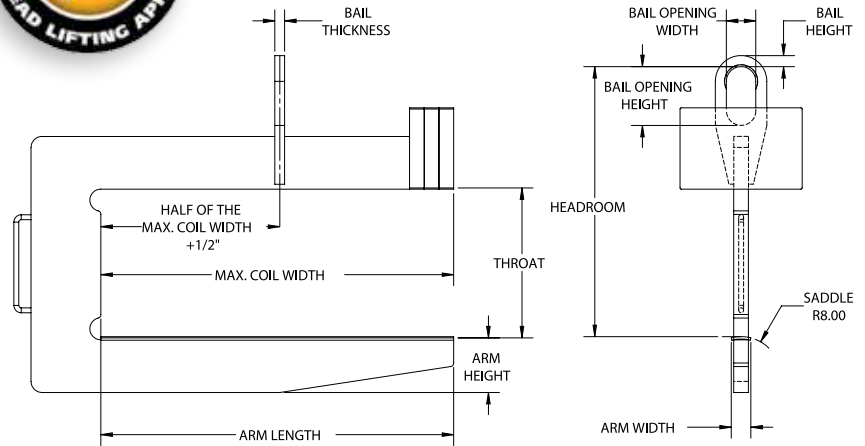

Model #	Capacity (US Tons)*	Dimensions (Inches)										Weight (Lbs.)
		Coil Width Max	Head-room	Lift Arm Length	Lift Arm Height	Lift Arm Width	Throat Opening Height	Bail Height	Bail Opening Width	Bail Opening Height	Bail Thickness	
CLSC-5-36	5	36	38	36	6.25	4	24	1.5	4	7	1.25	510
CLSC-5-48	5	48	38	48	6.25	4	24	1.5	4	7	1.25	740
CLSC-5-60	5	60	38.8	60	7	4	24	1.5	4	7	1.25	905
CLSC-7.5-36	7.5	36	38.3	36	6.5	4	24	1.5	4	7	1.5	730
CLSC-7.5-48	7.5	48	39	48	7.25	4	24	1.5	4	7	1.5	890
CLSC-7.5-60	7.5	60	39.8	60	8	4	24	1.5	4	7	1.5	1080
CLSC-10-48	10	48	42.5	48	8.25	4	24	2	5	9	1.75	1070
CLSC-10-60	10	60	42.5	60	8.25	4	24	2	5	9	1.75	1450
CLSC-10-72	10	72	43.3	72	9	4	24	2	5	9	1.75	1700
CLSC-15-48	15	48	49.3	48	9	4	30	2	5	9	1.75	1630
CLSC-15-60	15	60	50.3	60	10	4	30	2	5	9	1.75	1945
CLSC-15-72	15	72	51	72	10.75	4	30	2	5	9	1.75	2255
CLSC-20-60	20	60	54	60	10.5	4	30	2.75	6	12	2	2540
CLSC-20-72	20	72	55	72	11.5	4	30	2.75	6	12	2	2985
CLSC-25-60	25	60	61.5	60	11.75	4	34	3.25	6	14	2.5	3085
CLSC-25-72	25	72	62.5	72	12.75	4	34	3.25	6	14	2.5	3560

\* 1 US Ton = 2,000 Lbs



**DO NOT EXCEED CAPACITY!**  
See the SAFETY GUIDELINES section before using these products. Pages 92-95.



## COIL LIFTER VERTICAL

### FEATURES

- This style of lifter is designed to handle coils that are stacked vertically.
- Supplied with standard leg positioning handle with built in positive locking feature.
- Engineered and manufactured to ASME B30.20 & BTH-1 Design Category B Service Class 2.
- 100% of ALL Peerless Coil Lifters are Proof-Tested to 125% capacity and certificates supplied at No Additional Charge.

### OPTIONS

- Higher capacities
- Additional lengths
- Protective padding

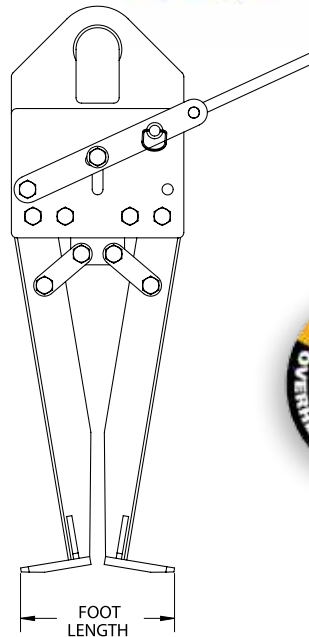
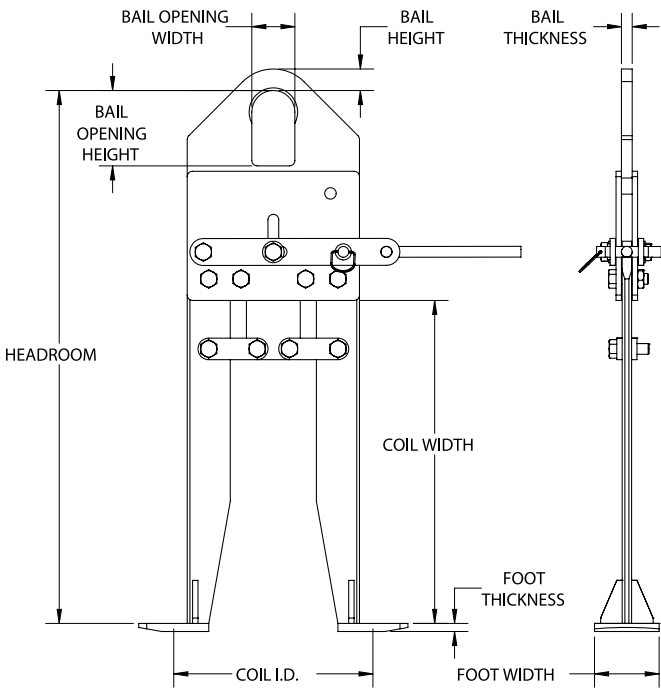
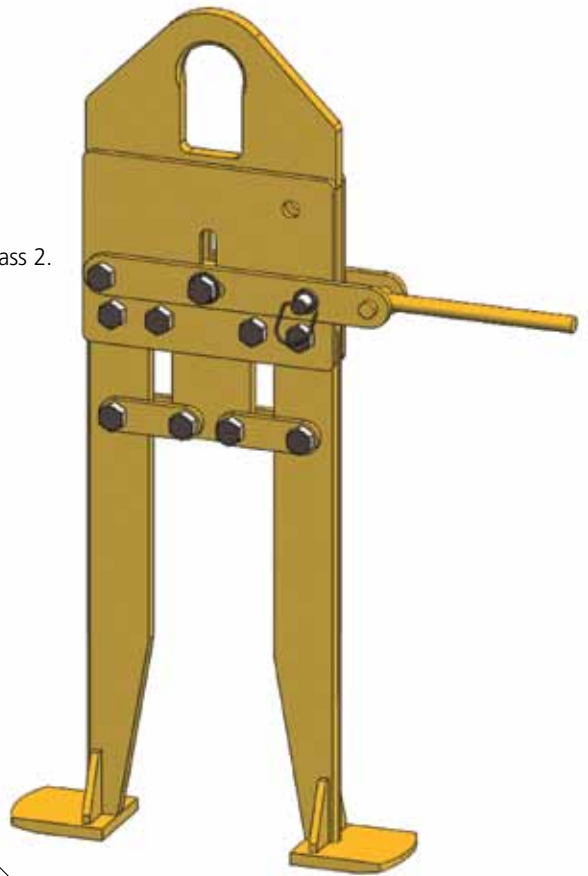

Model #	Capacity (US Tons)*	Dimensions (Inches)										Weight (Lbs.)
		Coil ID Min/Max	Coil Width Max	Head-room	Foot Width	Foot Thickness	Foot Length	Bail Height	Bail Opening Width	Bail Opening Height	Bail Thickness	
CLV-1/2-20	1/2	16/20	20	36	4	0.75	13	1.25	3	5	0.63	110
CLV-1.5-20	1.5	16/20	24	36	4	0.75	13	1.5	3	5	0.63	125
CLV-3-20	3	16/20	24	40	5	0.75	13.5	1.5	3	5	0.75	180
CLV-5-20	5	16/20	30	49	6	0.75	14.25	2	4	7	1	195

\* 1 US Ton = 2,000 Lbs



**DO NOT EXCEED CAPACITY!**  
See the SAFETY GUIDELINES section before using these products. Pages 92-95.



## COIL LIFTER VERTICAL WIDE

### FEATURES

- This style of lifter is designed to handle coils that are stacked vertically.
- Supplied with standard self-adjusting legs that automatically adjust to the I.D. of the coil.
- Engineered and manufactured to ASME B30.20 & BTH-1 Design Category B Service Class 2.
- 100% of ALL Peerless Coil Lifters are Proof-Tested to 125% capacity and certificates supplied at No Additional Charge.

### OPTIONS

- Higher capacities
- Additional lengths
- Protective padding

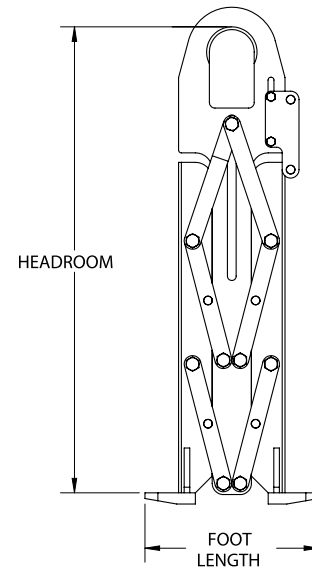
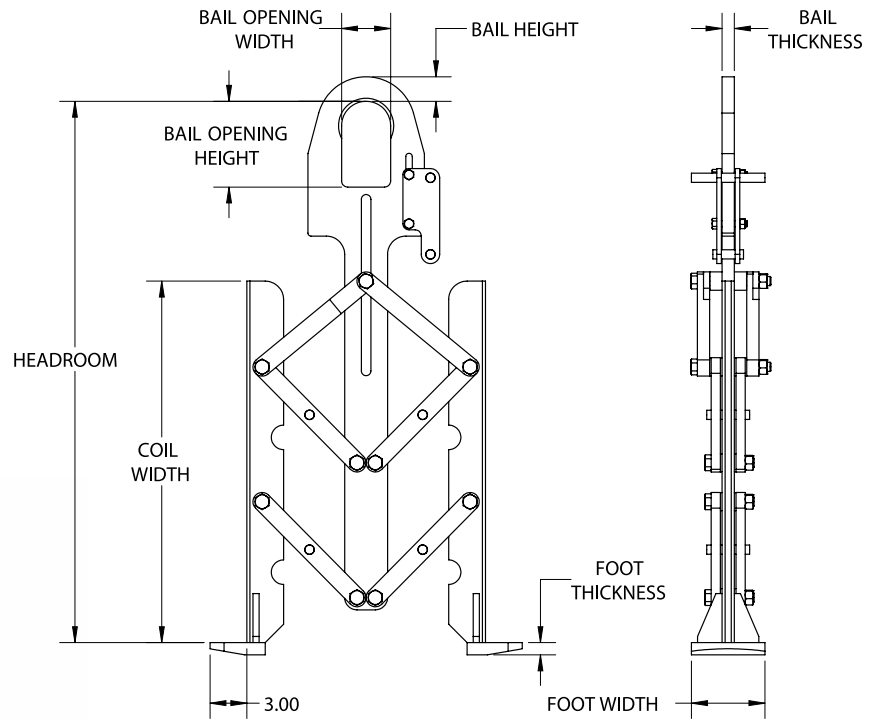
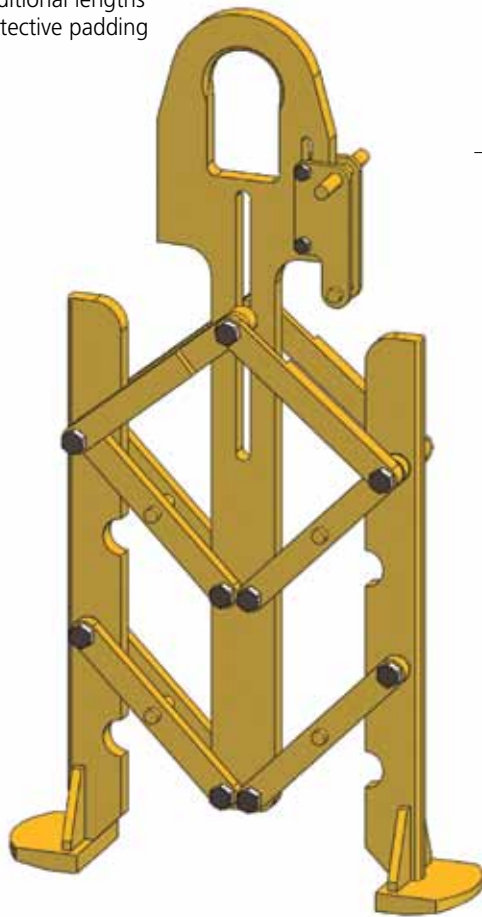

Model #	Capacity (US Tons)*	Coil ID Min/Max	Coil Width Max	Dimensions (Inches)									Weight (Lbs.)
				Headroom		Foot Width	Foot Thickness	Foot Length	Bail Height	Bail Opening Width	Bail Opening Height	Bail Thickness	
				Open	Closed								
CLVW-1/2-24	1/2	16/24	20	37	32	5	0.5	14.5	1.25	3	5	0.63	90
CLVW-2.5-24	2.5	16/24	24	45	38.5	5	0.75	15.5	1.5	3	5	0.75	125
CLVW-5-24	5	16/24	30	48	41.5	6	1	15.5	2	4	7	1	170
CLVW-7.5-24	7.5	16/24	30	48	41.5	6	1	15.5	2	4	8	1	170

\* 1 US Ton = 2,000 Lbs



**DO NOT EXCEED CAPACITY!**  
See the SAFETY GUIDELINES section before using these products. Pages 92-95.

# LIFTING EQUIPMENT



## COIL GRAB VERTICAL

### FEATURES

- This style of lifter is designed to handle coils that are stacked vertically.
- Supplied with manual adjusting legs that adjust to the I.D. of the coil with the standard hand wheel or optional chain wheel.
- Can be supplied with optional motorized leg drive.
- Engineered and manufactured to ASME B30.20 & BTH-1 Design Category B Service Class 2.
- 100% of ALL Peerless Coil Lifters are Proof-Tested to 125% capacity and certificates supplied at No Additional Charge.

### OPTIONS

- Higher capacities
- Additional lengths
- Protective padding
- Parking stands
- Motorized leg drive

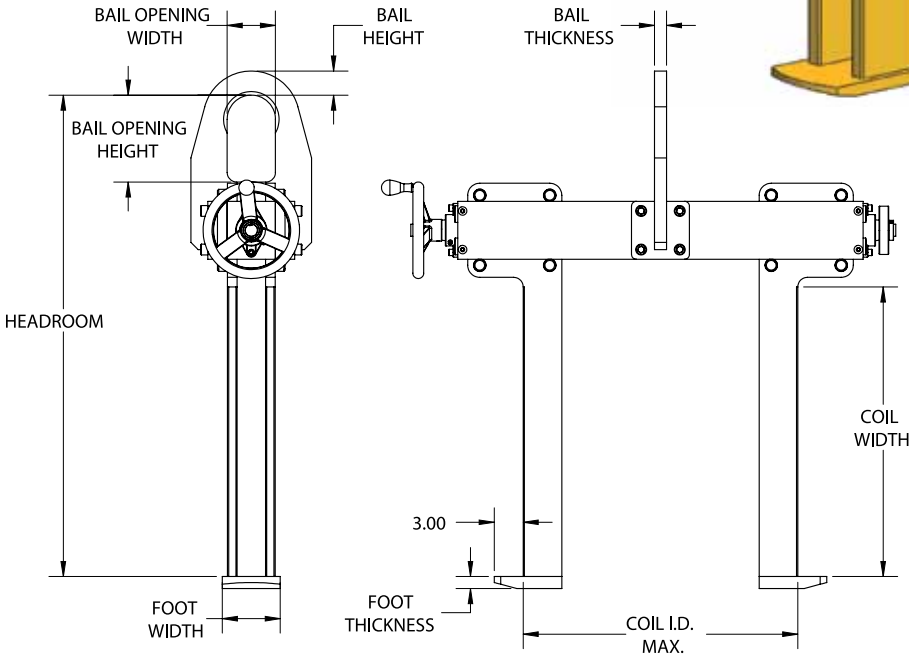
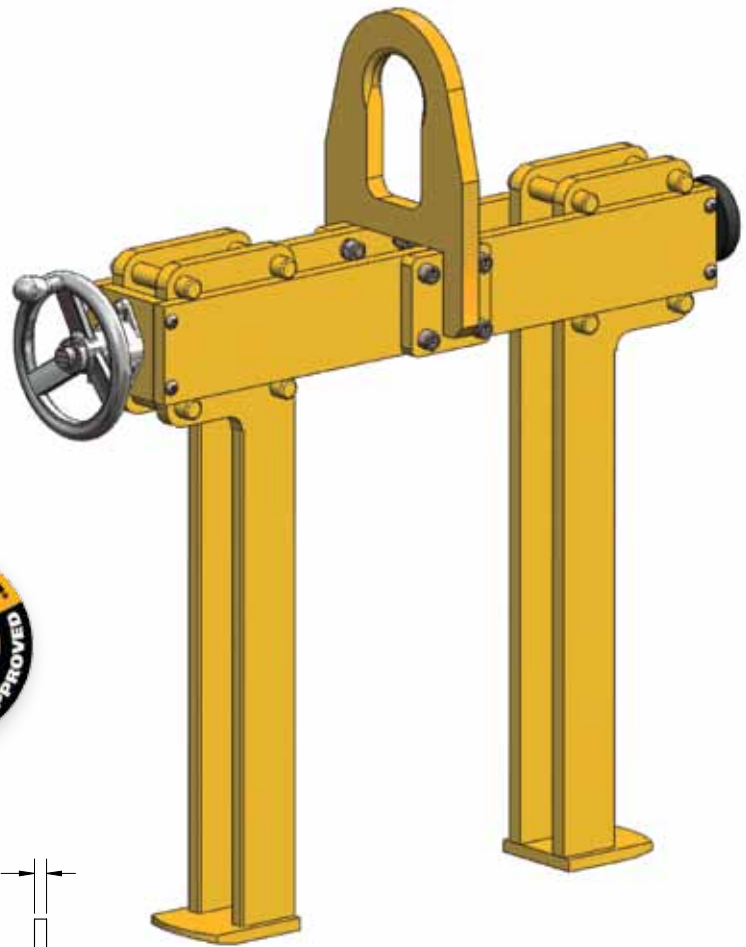

Model #	Capacity (US Tons)*	Coil ID Min/Max	Dimensions (Inches)									Weight (Lbs.)
			Coil Width Max	Headroom	Foot Width	Foot Thickness	Foot Length	Bail Height	Bail Opening Width	Bail Opening Height	Bail Thickness	
CGV-2.5-24	2.5	16/24	20	36	5	0.75	15.5	1.5	3	5	0.75	275
CGV-5-24	5	16/24	24	41	6	1	15.5	2	4	7	1	385
CGV-7.5-24	7.5	16/24	24	42	6	1	15.5	2	4	7	1	468
CGV-10-24	10	16/24	30	50	6	1.5	15.5	2.5	5	9	1.25	550

\* 1 US Ton = 2,000 Lbs



**DO NOT EXCEED CAPACITY!**  
See the SAFETY GUIDELINES section before using these products. Pages 92-95.





## COIL LIFTER TELESCOPIC TWO-SIDED

### FEATURES

- This style of lifter is designed to efficiently handle coils with the eye horizontal.
- The manual adjusting legs adjust to the I.D. of the coil with the standard chain wheel or an optional motorized leg drive and require less aisle space for operation.
- The self-locking gear drive prevents the inadvertent opening of the legs and curved foot pad minimizes coil damage.
- Engineered and manufactured to ASME B30.20 & BTH-1 Design Category B Service Class 2.
- 100% of ALL Peerless Coil Lifters are Proof-Tested to 125% capacity and certificates supplied at No Additional Charge.

### OPTIONS

- Higher capacities
- Additional lengths
- Protective padding
- Parking stands
- Motorized leg drive

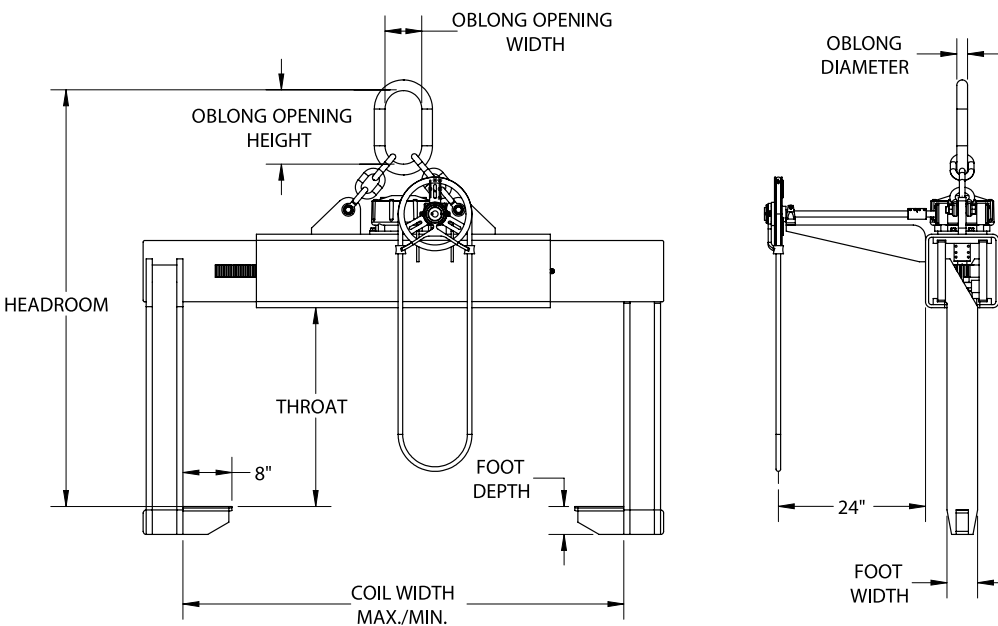
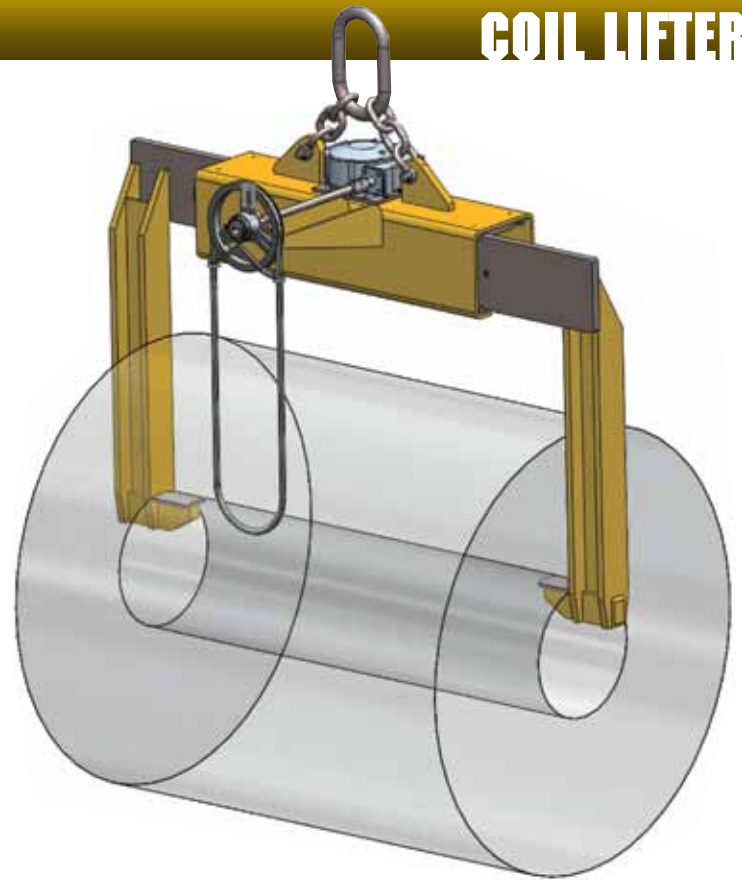

Model #	Capacity (US Tons)*	Dimensions (Inches)								Weight (Lbs.)
		Coil Width Min/Max	Throat Opening Height	Headroom	Foot Width	Foot Thickness	Oblong ML Diameter	Oblong ML Opening Width	Oblong ML Opening Height	
CLT-5-48	5	16/48	26	51	4	4	1	3.5	7	679
CLT-5-60	5	20/60	28	53	4	4	1	3.5	7	826
CLT-10-48	10	16/48	30	62	4	5	1.25	4.38	8.75	1015
CLT-10-60	10	20/60	32	64	4	5	1.25	4.38	8.75	1134
CLT-15-60	15	20/60	32	68	4	6	1.5	5.25	10.5	1302
CLT-15-72	15	24/72	34	70	4	6	1.5	5.25	10.5	1505

\* 1 US Ton = 2,000 Lbs



**DO NOT EXCEED CAPACITY!**  
See the SAFETY GUIDELINES section before using these products. Pages 92-95.

COIL LIFTERS



## NARROW ARM COIL LIFTER

### FEATURES

- This style of lifter is designed to economically handle coils with the eye horizontal.
- The manual adjusting legs easily adjust to the I.D. of the coil and require less aisle space for operation.
- Supplied with standard plate style legs with rounded corners to minimize coil damage. (Round bar legs can be supplied as an option).
- Engineered and manufactured to ASME B30.20 & BTH-1 Design Category B Service Class 2.
- 100% of ALL Peerless Coil Lifters are Proof-Tested to 125% capacity and certificates supplied at No Additional Charge.

### OPTIONS

- Higher capacities
- Additional lengths
- Round bar legs
- Protective padding
- Parking stands

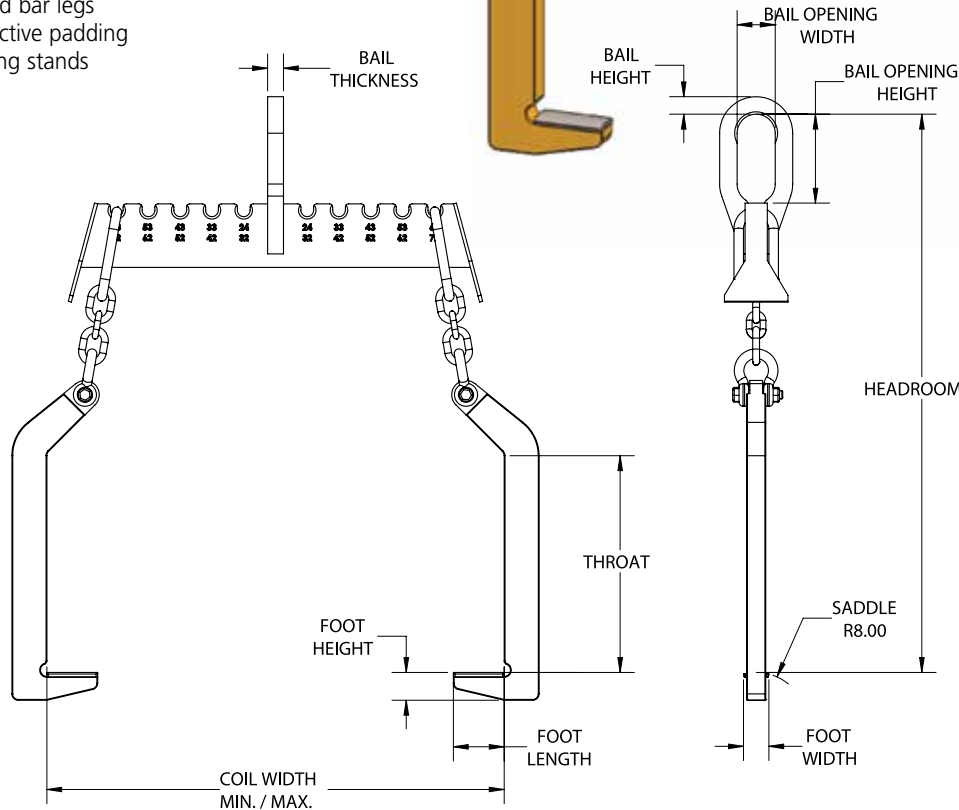
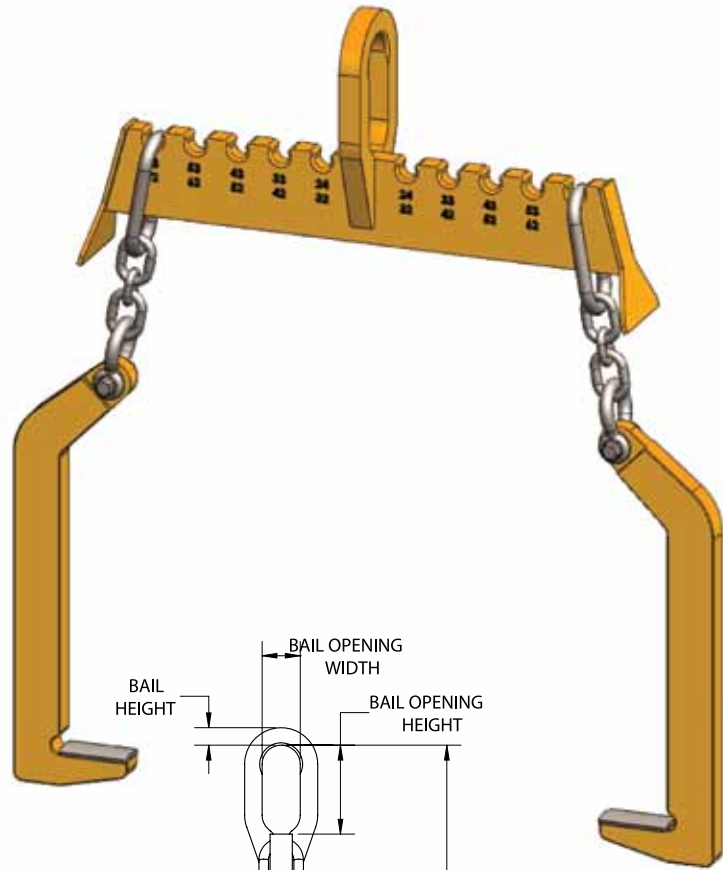

Model #	Capacity (US Tons)*	Dimensions (Inches)										Weight (Lbs.)
		Coil Width Min/Max	Throat Opening Height	Head-room	Foot Height	Foot Width	Foot Length	Bail Height	Bail Opening Width	Bail Opening Height	Bail Thickness	
NACL-10-48	10	20/48	24	64	4	4	8	2	5	9	1.25	310
NACL-15-48	15	20/48	28	75	4.25	4	8	2	5	9	1.75	510
NACL-20-60	20	24/60	30	80	4.5	4	8	2.25	6	12	2	680
NACL-25-60	25	24/60	34	89	4.5	4	8	2.5	6	14	2.25	870
NACL-30-72	30	24/72	34	89	4.5	4	8	2.75	6	14	2.5	1100

\* 1 US Ton = 2,000 Lbs



**DO NOT EXCEED CAPACITY!**  
See the SAFETY GUIDELINES section before using these products. Pages 92-95.

# COIL LIFTER

Custom Application Form



# PEERLESS®

A KITCO GROUP COMPANY

For pricing information: Fax completed form & contact info to (800)-356-1149

## LOAD INFORMATION:

Describe the material you are planning to lift: \_\_\_\_\_

Coil Lifter Type Needed: \_\_\_\_\_

Coil Dimensions:

Coil Stand Required:  Parking  Maintenance  None

	Min (in)	Max (in)
O.D.	_____	_____
I.D.	_____	_____
Width/Height	_____	_____
Weight	_____	_____

Coil Positioning During Lift:  Eye Vertical  Eye Horizontal

Coil Material  Steel  Aluminum  Other (specify): \_\_\_\_\_

Is Coil Telescoped:  Yes  No If Yes, Material Length \_\_\_\_\_  O.D.  L.D.

Coil Features:  Banded  Oily  Tight Wound  Loose Wound  Other (specify): \_\_\_\_\_

Coil Placement: Prior To Lift: \_\_\_\_\_ Post Lift: \_\_\_\_\_

Does The Lifter Require Protective Lining To Prevent Coil Damage:  Yes  No

Is The Coil Hot:  Yes  No

If Yes: Max Temp \_\_\_\_\_ Required Contact Time With Material: \_\_\_\_\_ Min Time Between Lifts: \_\_\_\_\_

## CRANE SPECIFICATIONS:

Distance Between Top Of The Load To The Crane Hook High Position(s): \_\_\_\_\_

Capacity Of The Crane(s): \_\_\_\_\_ Distance Between Cranes (if applicable): \_\_\_\_\_

Required Duty Cycle Of The Coil Lifter: Lifts Per Hour \_\_\_\_\_ Lifts Per Day \_\_\_\_\_

Crane Classification(s):  A  B  C  D  E  F

## MOTORIZED COIL LIFTER APPLICATION:

Operation:  Manual  Motorized:  AC  DC Voltage \_\_\_\_\_ Phase \_\_\_\_\_ Cycle \_\_\_\_\_

Controls Required:  Yes  No If Yes: Specify Type \_\_\_\_\_  Furnish Loose  Mounted On Lifter

## CRANE HOOK SPECIFICATIONS (Inches) :

A: \_\_\_\_\_ B: \_\_\_\_\_ C: \_\_\_\_\_ D: \_\_\_\_\_ E: \_\_\_\_\_ F: \_\_\_\_\_ G: \_\_\_\_\_ H: \_\_\_\_\_

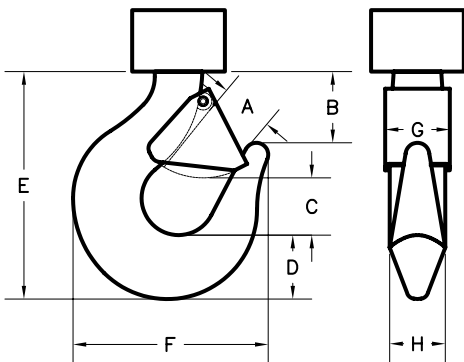

Please provide pertinent application information not supplied above (*extreme product or operating temperature, extreme environmental conditions such as temperature or moisture, space or headroom restrictions, additional specifications*):

\_\_\_\_\_

\_\_\_\_\_

\_\_\_\_\_



**PEERLESS**  
A KITO GROUP COMPANY



# OBLONG MASTER LINKS

PROUDLY FORGED IN THE USA

- *Welded & Forged Alloy Steel with either a self-colored or powder coated finish*
- Peerless exceeds ASTM A906 & A952 requirements
- All Peerless product is proof tested
- Each Forged\* link marked with the following:
  - USA
  - Peerless "P" logo
  - Traceability & heat code
  - A10 Designating Grade 100
  - Manufacturer's mark
  - Angle indicators at 45° from vertical



STOCK #		TRADE SIZE		Forged or Welded	Dimensions (Inches)			Lbs. per Each	Working Load Limit (Lbs.)	Proof Load (Lbs.)
Self-Colored	Painted	Inches	mm							
OMA041	---	13/32	10	Welded	0.41	1.5	3	0.3	3,600	7,200
8810005	8810003	1/2	13	Forged*	0.58	2.54	5.01	1.1	7,400	17,200
8810015	8810014	3/4	19	Forged*	0.76	3.04	6.01	2.9	15,200	35,200
8810025	8810024	1	26	Forged*	1.01	4.04	8.01	5.6	26,000	60,000
8810030	8810029	1-1/4	32	Forged*	1.34	5.5	9.5	11.6	39,100	90,400
8810035	8810034	1-1/2	38	Forged*	1.6	5.9	10.5	18.2	61,100	141,200
8810040	8810039	1-3/4	44	Forged*	1.75	6	12	24.9	84,900	196,000
OMA200	OMA200P	2	50	Welded	2	7	14	37	88,900	177,800
OMA225	OMA225P	2-1/4	57	Welded	2.25	8	16	63	125,200	250,400
OMA250	OMA250P	2-1/2	63	Welded	2.5	8	16	67.7	147,300	294,600
OMA275	OMA275P	2-3/4	70	Welded	2.75	9	16	83.7	187,800	375,600

\*\*Ultimate load meets ASTM A952 specifications, based on a single leg sling at 90° or a double leg sling at 60° from horizontal.



## **BTF**

Bar Tong Fixed .....Page 62

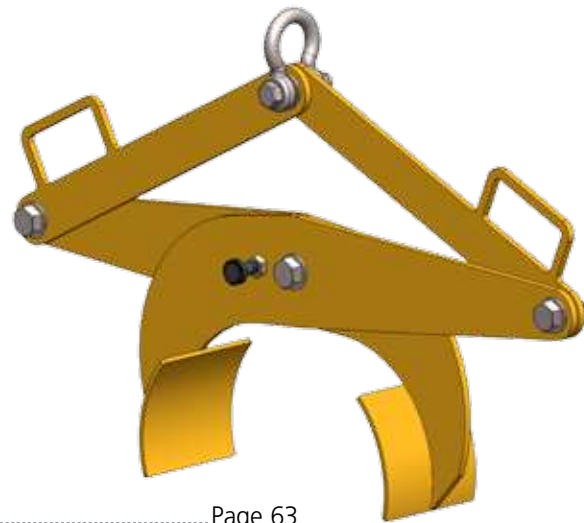

## **BTA**

Bar Tong Adjustable.....Page 63



## BTF BAR TONG FIXED

### FEATURES

- This style of fixed diameter tong is ideal for lifting round bars, cast or steel pipe.
- The load must be balanced during the lift.
- Can be used in pairs attached to a lifting/spreader beam to handle longer loads.
- Engineered and manufactured to ASME B30.20 & BTH-1 Design Category B Service Class 2.
- 100% of ALL Peerless Tongs are Proof-Tested to 125% capacity and certificates supplied at No Additional Charge.

### OPTIONS

- Higher capacities available



TONGS

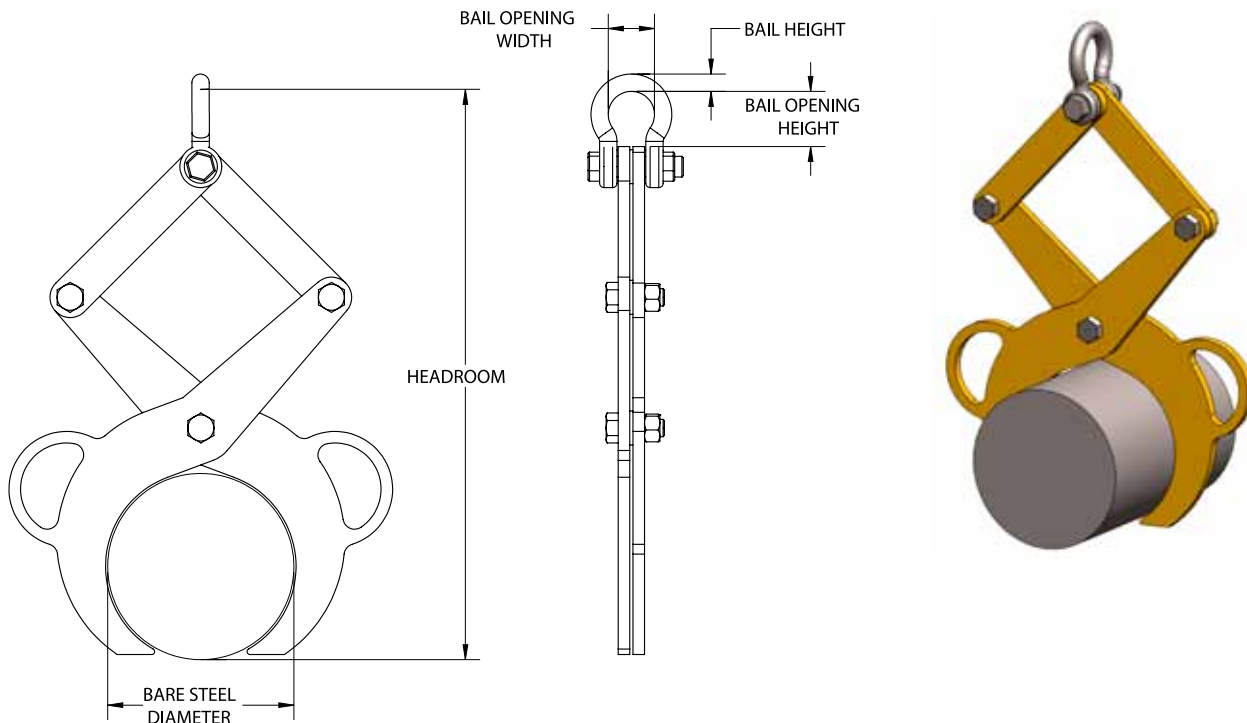

Model #	Capacity (US Tons)*	Dimensions (Inches)					Weight (Lbs.)
		Bare Steel Diameter	Headroom	Bail Height	Bail Opening Width	Bail Opening Height	
BTF-1/2-5	1/2	5	17.00	0.63	1.69	1.69	17
BTF-1-8	1	8	25.00	0.75	2	2	25

\* 1 US Ton = 2,000 Lbs



**DO NOT EXCEED CAPACITY!**  
See the SAFETY GUIDELINES section before using these products. Pages 92-95.



## BTA BAR TONG ADJUSTABLE

### FEATURES

- This style of adjustable diameter tong is ideal for lifting round bars, cast or steel pipe of various diameters.
- Hold open latch supplied on all 1 ton standard tongs.
- Can be supplied with optional replaceable urethane pads for additional load protection.
- The load must be balanced during the lift.
- Can be used in pairs attached to a lifting/spreader beam to handle longer loads.
- Engineered and manufactured to ASME B30.20 & BTH-1 Design Category B Service Class 2.
- 100% of ALL Peerless Tongs are Proof-Tested to 125% capacity and certificates supplied at No Additional Charge.

### OPTIONS

- Replaceable urethane pads
- Hold open latch
- Higher capacities available

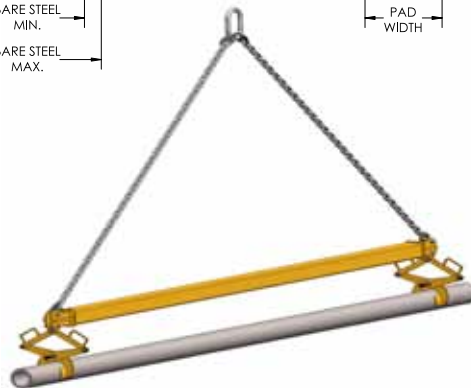
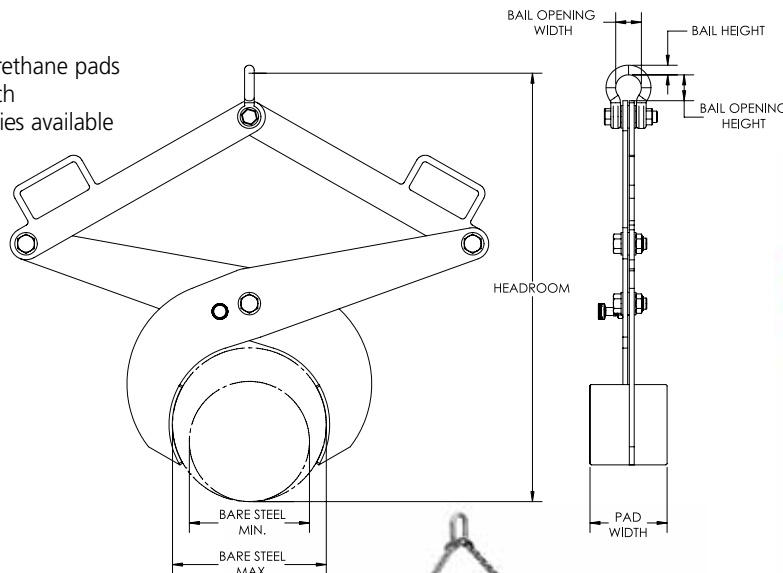
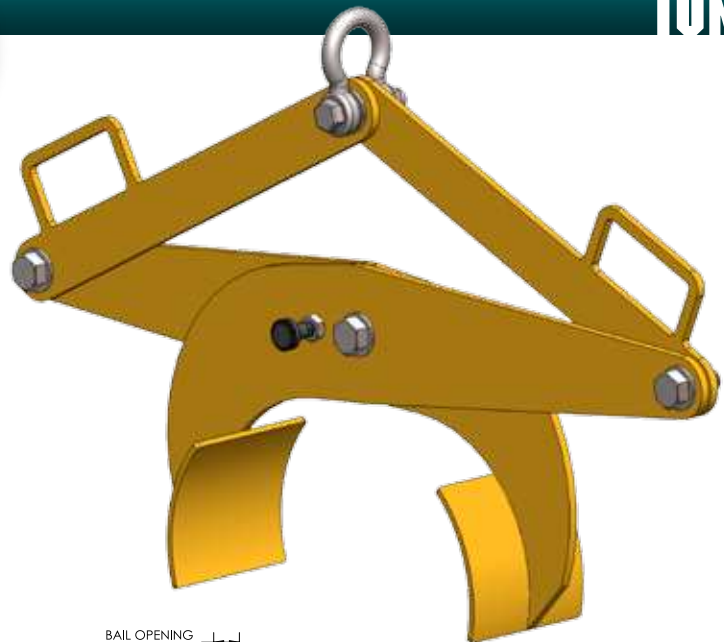

Model #	Capacity (US Tons)*	Dimensions (Inches)										Weight (Lbs.)
		Bare Steel Range Min	Bare Steel Range Max	Urethane Pad Range Min	Urethane Pad Range Max	Head-room Max	Head-room Min	Pad Width	Bail Height	Bail Opening Width	Bail Opening Height	
BTA-1/2-2.5/4	1/2	2.5	4	1.75	3.25	15	13	2.25	0.63	1.69	1.69	10
BTA-1-4/7	1	4	7	3.25	6.25	24	21	5	0.63	1.69	1.69	25
BTA-1-7/12	1	7	12	6.25	11.25	38	34	6	0.75	2	2	55
BTA-1-10/15	1	10	15	9.25	14.25	46	41	6	0.75	2	2	115
BTA-1-15/20	1	15	20	14.25	19.25	65	60	8	0.97	2.28	2.28	225

\* 1 US Ton = 2,000 Lbs



**DO NOT EXCEED CAPACITY!**  
See the SAFETY GUIDELINES section before using these products. Pages 92-95.

TONGS

### LOAD INFORMATION:

Describe the material you are planning to lift: \_\_\_\_\_

#### Tong Type Needed:

Friction (Designed to lift tubes, rolls, round bars, pipe, & other cylindrical materials)

##### Friction Tong Load Dimensions:

Min (inches) O.D. \_\_\_\_\_ I.D. \_\_\_\_\_ Length \_\_\_\_\_ Weight \_\_\_\_\_

Max (inches) O.D. \_\_\_\_\_ I.D. \_\_\_\_\_ Length \_\_\_\_\_ Weight \_\_\_\_\_

Desired Tong Lift Point:  O.D.  I.D.  Ends

Supporting (Designed to lift crates, boxes, containers, & other square/rectangular shaped materials)

Indentation (Designed to lift ingots, boxes, bales, and other straight sided materials)

##### Supporting/Indentation Tong Load Dimensions:

Min (inches) Width \_\_\_\_\_ Length \_\_\_\_\_ Height \_\_\_\_\_ Weight \_\_\_\_\_

Max (inches) Width \_\_\_\_\_ Length \_\_\_\_\_ Height \_\_\_\_\_ Weight \_\_\_\_\_

Desired Tong Lift Point:  Width Side  Length Side

Product Positioning Prior Lift:  Flat Surface  Rack  Other (specify): \_\_\_\_\_

Product Positioning Post Lift:  Flat Surface  Rack  Other (specify): \_\_\_\_\_

Does Lifter Require Protective Lining To Prevent Damage To The Load:  Yes  No

Is A Latch Required (Used to assist with hands-free operation):  Yes  No

Is An Auto-Latch Required (Used to assist with hands-free operation):  Yes  No

Is The Load Hot:  Yes  No

If Yes: Max Temp: \_\_\_\_\_ Required Lifter/Load Contact Time : \_\_\_\_\_ Min Time Between Lifts \_\_\_\_\_

### CRANE SPECIFICATIONS:

Distance Between Top Of The Load To The Crane Hook High Position: \_\_\_\_\_

Capacity Of The Crane: \_\_\_\_\_

Required Duty Cycle Of The Roll Lifter: Lifts Per Hour \_\_\_\_\_ Lifts Per Day \_\_\_\_\_

Crane Classification(s):  A  B  C  D  E  F

### CRANE HOOK SPECIFICATIONS (Inches) :

A: \_\_\_\_\_ B: \_\_\_\_\_ C: \_\_\_\_\_ D: \_\_\_\_\_ E: \_\_\_\_\_ F: \_\_\_\_\_ G: \_\_\_\_\_ H: \_\_\_\_\_

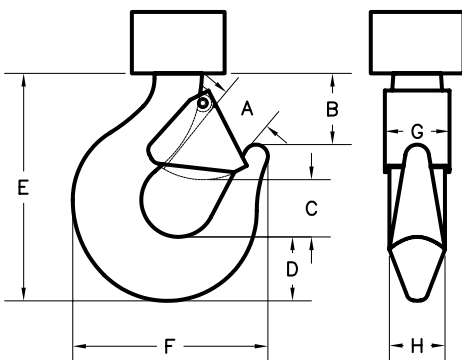

Please provide pertinent application information not supplied above (extreme product or operating temperature, extreme environmental conditions such as temperature or moisture, space or headroom restrictions, additional specifications):

\_\_\_\_\_

\_\_\_\_\_

\_\_\_\_\_

\_\_\_\_\_



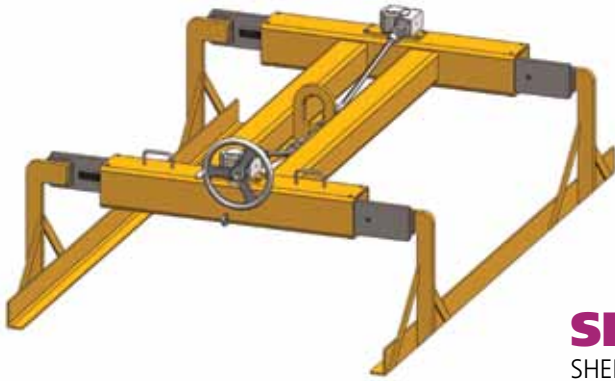

## SLHD

SHEET LIFTER HEAVY DUTY .....Page 66

## MSLHD

MOTORIZED SHEET LIFTER HEAVY DUTY .....Page 67

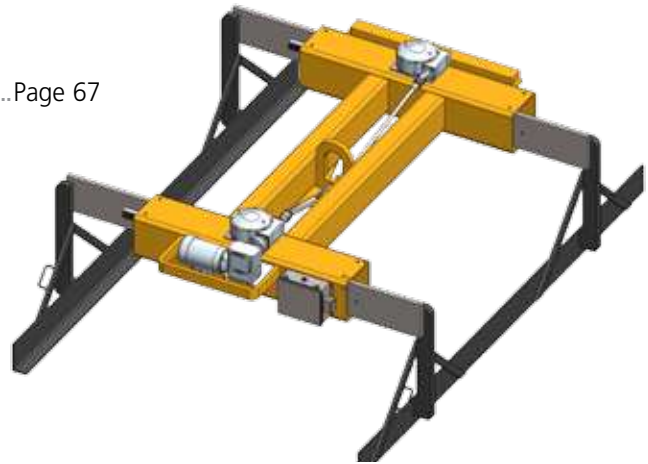

SHEET LIFTERS



## SLLD

SHEET LIFTER LIGHT DUTY.....Page 68

## SLHD SHEET LIFTER HEAVY DUTY

### FEATURES

- This style of lifter is designed to lift and carry various sizes of bundles, sheets, and/or plates.
- Standard heavy duty direct drive, self-locking, machined rack and pinion leg adjustment.
- Standard heavy duty square tube H-Frame design.
- Standard heavy duty hand-wheel package with slip clutch to prevent damage to gearboxes from over adjustment.
- Easily maintained low headroom design.
- Engineered and manufactured to ASME B30.20 & BTH-1 Design Category B Service Class 2.
- 100% of ALL Peerless Sheet Lifters are Proof-Tested to 125% capacity and certificates supplied at No Additional Charge.



### OPTIONS

- Chain wheel leg drive
- Extended hand wheel or chain wheel
- Extended shoe lengths
- Extended leg heights
- Load chains with plate hooks
- Load chains standard on all units with load width capabilities of 72" or greater

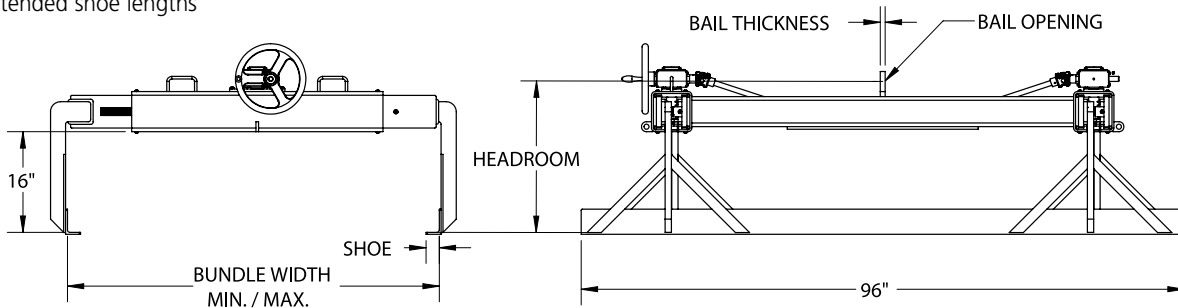

SHEET LIFTERS

Model #	Capacity (US Tons)*	Dimensions (Inches)								Weight (Lbs.)
		Bundle Width Min/Max	Headroom	Shoe Width	Min. Aisle	Bail Height	Bail Opening Width	Bail Opening Height	Bail Thickness	
SLHD-3-48	3	16/48	26	2.63	9	1.5	3	5	0.75	1370
SLHD-3-60	3	16/60	26	2.63	9	1.5	3	5	0.75	1420
SLHD-3-72	3	16/72	26	2.63	9	1.5	3	5	0.75	1460
SLHD-5-48	5	16/48	26	2.63	9	2	4	6	1	1670
SLHD-5-60	5	16/60	26	2.63	9	2	4	6	1	1740
SLHD-5-72	5	16/72	26	2.63	9	2	4	6	1	1820
SLHD-5-84	5	16/84	26	2.63	9	2	4	6	1	1890
SLHD-5-96	5	16/96	26	2.63	9	2	4	6	1	2300
SLHD-10-48	10	16/48	27	3.5	11	2	4	7	1.5	2700
SLHD-10-60	10	16/60	27	3.5	11	2	4	7	1.5	2800
SLHD-10-72	10	16/72	27	3.5	11	2	4	7	1.5	2930
SLHD-10-84	10	16/84	27	3.5	11	2	4	7	1.5	3030
SLHD-10-96	10	16/96	27	3.5	11	2	4	7	1.5	3150
SLHD-15-48	15	16/48	29	3.5	12	2.5	5	9	1.5	2890
SLHD-15-60	15	16/60	29	3.5	12	2.5	5	9	1.5	3220
SLHD-15-72	15	16/72	29	3.5	12	2.5	5	9	1.5	3340
SLHD-15-84	15	38/84	29	3.5	12	2.5	5	9	1.5	3850
SLHD-15-96	15	38/96	29	3.5	12	2.5	5	9	1.5	3980
SLHD-20-48	20	16/48	37	5.25	15	2.5	5	9	1.5	3255
SLHD-20-60	20	16/60	37	5.25	15	2.5	5	9	1.5	3560
SLHD-20-72	20	16/72	37	5.25	15	2.5	5	9	1.5	3875
SLHD-20-84	20	38/84	37	5.25	15	2.5	5	9	1.5	4550
SLHD-20-96	20	38/96	37	5.25	15	2.5	5	9	1.5	4900

\* 1 US Ton = 2,000 Lbs



**DO NOT EXCEED CAPACITY!**  
See the SAFETY GUIDELINES section before using these products. Pages 92-95.



## MSLHD MOTORIZED SHEET LIFTER HEAVY DUTY

### FEATURES

- This style of lifter is designed to lift and carry various sizes of bundles, sheets, and/or plates.
- Standard heavy duty direct drive, self-locking, machined rack and pinion leg adjustment.
- Standard heavy duty square tube H-Frame design.
- Standard heavy duty motor package with slip clutch to prevent damage to gearboxes from over adjustment.
- Easily maintained low headroom design.
- Engineered and manufactured to ASME B30.20 & BTH-1 Design Category B Service Class 2.
- 100% of ALL Peerless Sheet Lifters are Proof-Tested to 125% capacity and certificates supplied at No Additional Charge.

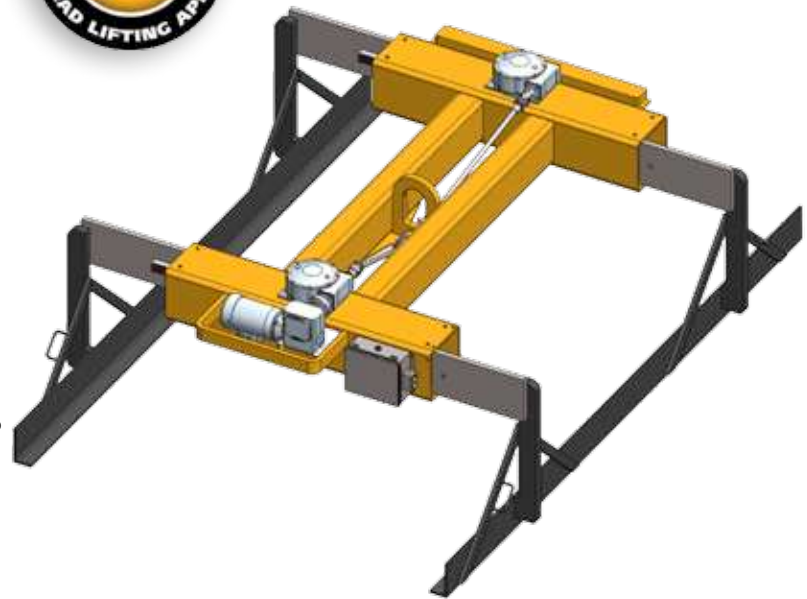

### OPTIONS

- Extended shoe lengths
- Extended leg heights
- Load chains with plate hooks
- Load chains standard on all units with load width capabilities of 72" or greater

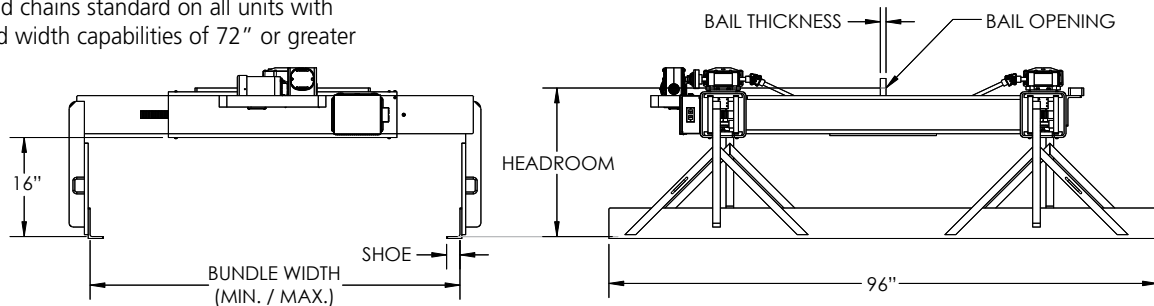

Model #	Capacity (US Tons)*	Dimensions (Inches)								Weight (Lbs.)
		Bundle Width Min/Max	Headroom	Shoe Width	Min. Aisle	Bail Height	Bail Opening Width	Bail Opening Height	Bail Thickness	
MSLHD-3-48	3	16/48	26	2.63	9	1.5	3	5	0.75	1770
MSLHD-3-60	3	16/60	26	2.63	9	1.5	3	5	0.75	1820
MSLHD-3-72	3	16/72	26	2.63	9	1.5	3	5	0.75	1860
MSLHD-5-48	5	16/48	26	2.63	9	2	4	6	1	2070
MSLHD-5-60	5	16/60	26	2.63	9	2	4	6	1	2140
MSLHD-5-72	5	16/72	26	2.63	9	2	4	6	1	2220
MSLHD-5-84	5	16/84	26	2.63	9	2	4	6	1	2290
MSLHD-5-96	5	16/96	26	2.63	9	2	4	6	1	2700
MSLHD-10-48	10	16/48	27	3.5	11	2	4	7	1.5	3100
MSLHD-10-60	10	16/60	27	3.5	11	2	4	7	1.5	3200
MSLHD-10-72	10	16/72	27	3.5	11	2	4	7	1.5	3330
MSLHD-10-84	10	16/84	27	3.5	11	2	4	7	1.5	3430
MSLHD-10-96	10	16/96	27	3.5	11	2	4	7	1.5	3450
MSLHD-15-48	15	16/48	29	3.5	12	2.5	5	9	1.5	3290
MSLHD-15-60	15	16/60	29	3.5	12	2.5	5	9	1.5	3620
MSLHD-15-72	15	16/72	29	3.5	12	2.5	5	9	1.5	3740
MSLHD-15-84	15	38/84	29	3.5	12	2.5	5	9	1.5	4250
MSLHD-15-96	15	38/96	29	3.5	12	2.5	5	9	1.5	4380
MSLHD-20-48	20	16/48	37	5.25	15	2.5	5	9	1.5	3655
MSLHD-20-60	20	16/60	37	5.25	15	2.5	5	9	1.5	3960
MSLHD-20-72	20	16/72	37	5.25	15	2.5	5	9	1.5	4275
MSLHD-20-84	20	38/84	37	5.25	15	2.5	5	9	1.5	4900
MSLHD-20-96	20	38/96	37	5.25	15	2.5	5	9	1.5	5200

\* 1 US Ton = 2,000 Lbs



**DO NOT EXCEED CAPACITY!**  
See the SAFETY GUIDELINES section before using these products. Pages 92-95.



## SHEET LIFTER LIGHT DUTY

### FEATURES

- This style of lifter is designed to lift and carry smaller sizes of bundles, sheets, and/or plates.
- Standard direct drive, self-locking, rack and pinion leg adjustment.
- Standard hand-wheel with slip clutch to prevent damage to gearboxes from over adjustment.
- Utilizes a sling style bail that adds stability and provides ease of maintenance on the gearbox and pinion gear assembly.
- Easily maintained low headroom design.
- Engineered and manufactured to ASME B30.20 & BTH-1 Design Category B Service Class 2.
- 100% of ALL Peerless Sheet Lifters are Proof-Tested to 125% capacity and certificates supplied at No Additional Charge.

### OPTIONS

- Chain wheel leg drive
- Extended hand wheel or chain wheel
- Extended shoe lengths
- Extended leg heights
- Load chains with plate hooks

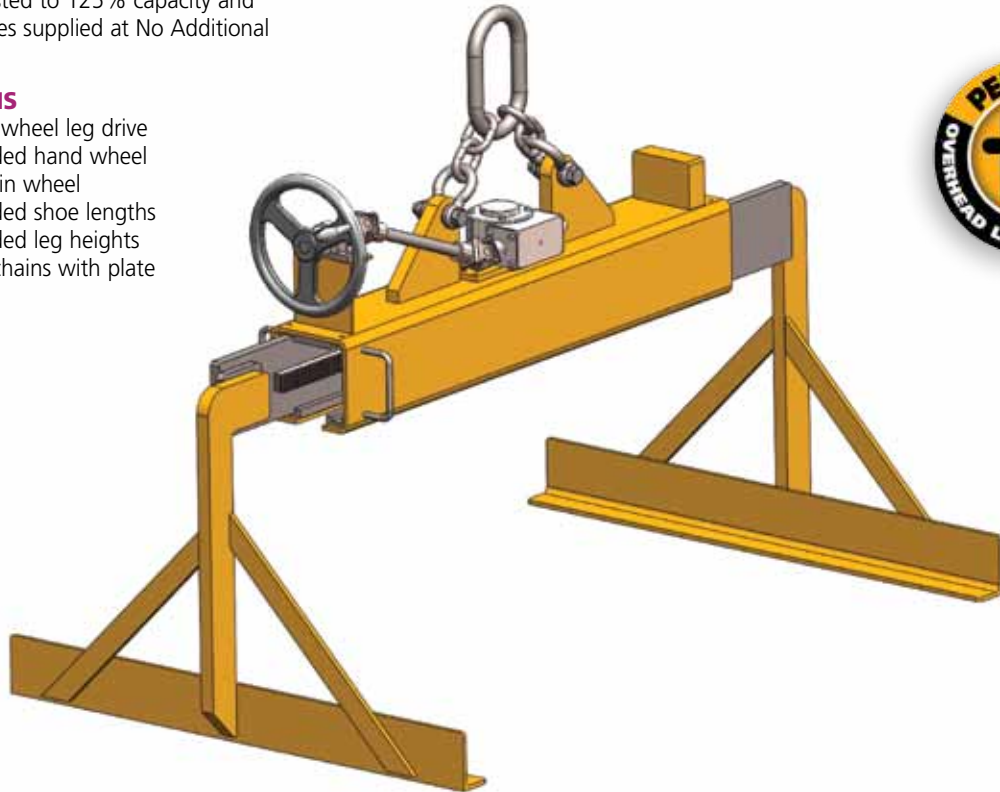
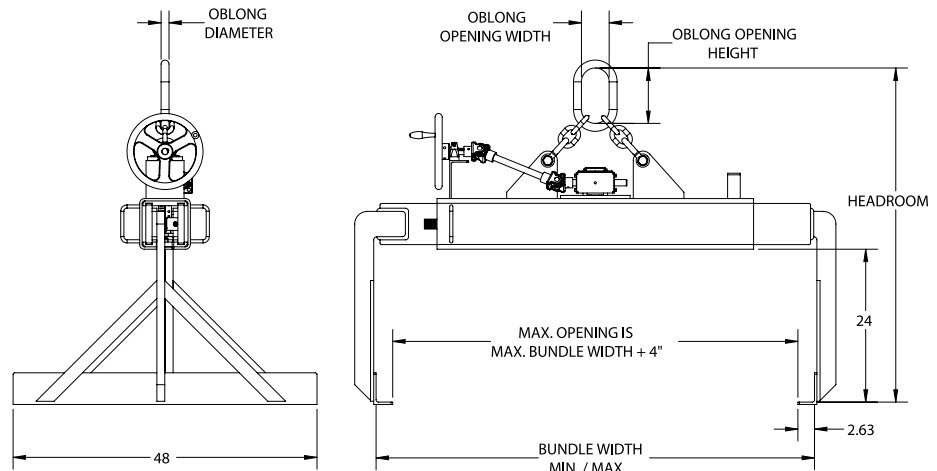

SHEET LIFTERS

Model #	Capacity (US Tons)*	Dimensions (Inches)							Weight (Lbs.)
		Bundle Width Min/Max	Headroom	Shoe Width	Min. Aisle	Oblong ML Diameter	Oblong ML Opening Width	Oblong ML Opening Height	
SLLD-1.5-36	1.5	12/36	44	2.63	8	0.63	3	6	507
SLLD-1.5-48	1.5	16/48	44	2.63	8	0.63	3	6	520
SLLD-3-48	3	16/48	46	2.63	8	1	3.5	7	660
SLLD-3-60	3	20/60	46	2.63	8	1	3.5	7	730
SLLD-5-48	5	16/48	54	2.63	8	1	4.38	8.75	745
SLLD-5-60	5	20/60	54	2.63	8	1	4.38	8.75	755

\* 1 US Ton = 2,000 Lbs



**DO NOT EXCEED CAPACITY!**  
See the SAFETY GUIDELINES section before using these products. Pages 92-95.

# SHEET LIFTER

Custom Application Form



# PEERLESS

A KITO GROUP COMPANY

For pricing information: Fax completed form & contact info to (800)-356-1149

## LOAD INFORMATION:

Describe the material you are planning to lift: \_\_\_\_\_

Material Conditions:  Banded  Loose  Dry  Oily

Bundled Load Dimensions:

Manual (adjustment):  Yes  No

	Min (in)	Max (in)
Height	_____	_____
Width	_____	_____
Length	_____	_____
Weight	_____	_____

If Yes: Max Temp \_\_\_ Req Contact Time \_\_\_ Min Time Between Lifts \_\_\_

Will Individual Sheets Be Handled?  Yes  No

If Yes: Individual Sheet Plate Thickness (inches) Max \_\_\_\_\_ Min \_\_\_\_\_

Is The Load Palletized?  Yes  No

If Yes: Pallet Dimensions (inches) Height \_\_\_\_\_ Width \_\_\_\_\_ Length \_\_\_\_\_ Weight \_\_\_\_\_

## SHEET LIFTER SPECIFICATIONS:

Operation:  Manual  Motorized  Hydraulic

If Manual (adjustment):  Hand Wheel  Chain Wheel  Extended Reach

If Motorized:  AC  DC Voltage \_\_\_\_\_ Phase \_\_\_\_\_ Cycle \_\_\_\_\_

If Yes Specify Type \_\_\_\_\_  Furnish Loose  Mounted On Lifter

Controls Required:  Yes  No

Load Chains With Plate Hooks:  Yes  No

Distance Between Top Of The Load To The Crane Hook High Position(s): \_\_\_\_\_

Capacity Of The Crane(s): \_\_\_\_\_

Required Duty Cycle Of The Sheet Lifter: Lifts Per Hour \_\_\_\_\_ Lifts Per Day \_\_\_\_\_

Crane Classification(s):  A  B  C  D  E  F

## CRANE HOOK SPECIFICATIONS (Inches):

A: \_\_\_ B: \_\_\_ C: \_\_\_ D: \_\_\_ E: \_\_\_ F: \_\_\_ G: \_\_\_ H: \_\_\_

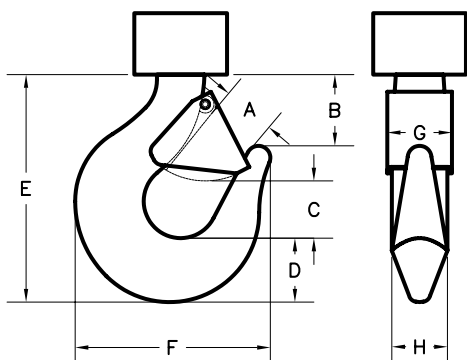

Please provide pertinent application information not supplied above (extreme product or operating temperature, extreme environmental conditions such as temperature or moisture, space or headroom restrictions, additional specifications):

---



---



---



---



---



# PEERLESS®

A KITO GROUP COMPANY

## Peerless Industrial Group Inc., the Largest U.S. Chain Manufacturer

Peerless Industrial Group has been innovating successful products for 100 years. Today, as a worldwide provider of lifting solutions, utilizing our exceptional design, engineering, manufacturing, and quality teams, we continue to develop crucial products for the wide variety of markets we serve. Peerless is part of KITO Corporation's global network providing our customers access to overhead lifting, below-the-hook and material handling, cargo control, hardware, marine and traction products.

**PEERLESS, YOUR LINK TO QUALITY,  
STRENGTH & SERVICE.**



**NEW INDUSTRIAL  
CATALOG NOW  
AVAILABLE!!!**



• Visit Us Online: [www.peerlesschain.com](http://www.peerlesschain.com) | 800.873.1916

## PL

FIXED FORK PALLET LIFTER .....Page 72



## PLAF

ADJUSTABLE FORK PALLET LIFTER.....Page 73



## PLHW

ADJUSTABLE FORK PALLET LIFTER.....Page 74



## PLHD

FIXED FORK HEAVY DUTY PALLET LIFTER.....Page 75



## PLHA

ADJUSTABLE FORK HEAVY DUTY PALLET LIFTER.....Page 76



## PLAH

ADJUSTABLE FORK HEAVY DUTY PALLET LIFTER  
w/Hand Wheel.....Page 77



## PLWL

WHEELED PALLET LIFTER .....Page 78



## PLLW

LIGHTWEIGHT PALLET LIFTER .....Page 79





## FIXED FORK PALLET LIFTER

### FEATURES

- This style of lifter is designed to lift and carry palletized loads efficiently with an overhead crane.
- Counter balanced to hang level when unloaded.
- Easily maintained low headroom design.
- The bail is a lower headroom design and is positioned to avoid side loading the crane hook.
- Engineered and manufactured to ASME B30.20 & BTH-1 Design Category B Service Class 2.
- 100% of ALL Peerless Pallet Lifters are Proof-Tested to 125% capacity and certificates supplied at No Additional Charge.

### OPTIONS

- Larger throat openings
- Greater outside fork widths
- Additional sizes and capacities available

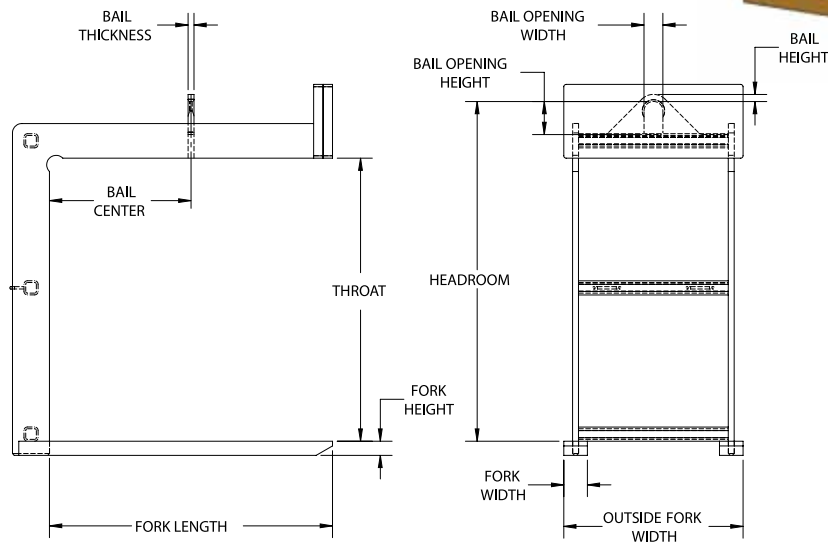
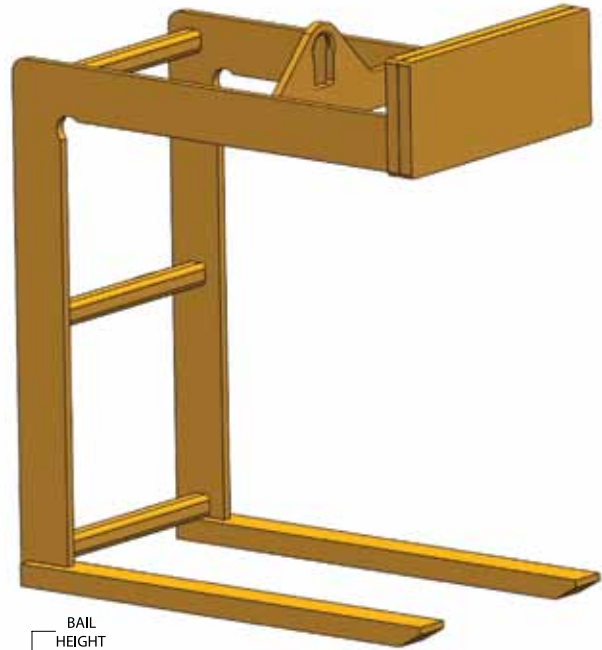

PALLET LIFTERS

Model #	Capacity (US Tons)*	Dimensions (Inches)											Weight (Lbs.)
		Fork Length	Fork Width	Fork Height	Outside Fork Width	Bail Center	Throat Opening Height	Headroom	Bail Height	Bail Opening Width	Bail Opening Height	Bail Thickness	
PL-1-36	1	36	2	2	25	18	48	57.5	0.88	3	5	0.75	425
PL-1-42	1	42	2	2	25	21	48	57.5	0.88	3	5	0.75	450
PL-1-48	1	48	2	2	25	24	48	58.5	0.88	3	5	0.75	540
PL-1.5-36	1.5	36	3	2	25	18	48	58.5	0.88	3	5	0.75	565
PL-1.5-42	1.5	42	3	2	25	21	48	58.5	0.88	3	5	0.75	630
PL-1.5-48	1.5	48	3	2	25	24	48	58.5	0.88	3	5	0.75	665
PL-2-36	2	36	3	2	25	18	48	59.5	0.88	3	5	0.75	650
PL-2-42	2	42	4	2	25	21	48	59.5	0.88	3	5	0.75	780
PL-2-48	2	48	4	2	25	24	48	59.5	0.88	3	5	0.75	910
PL-3-42	3	42	4.5	2.5	25	21	48	61.5	1.25	3	5	1	1110
PL-3-48	3	48	4.5	2.5	27	24	48	61.5	1.25	3	5	1	1195
PL-3-54	3	54	4.5	2.5	30	27	48	61.5	1.25	3	5	1	1405
PL-4-48	4	48	5	3	27	24	48	63.5	1.25	3	5	1	1705
PL-4-60	4	60	5	3	30	30	60	75.5	1.25	3	5	1	2020
PL-5-48	5	48	5	3	30	24	48	63.5	1.5	4	7	1.25	1730
PL-5-60	5	60	5	3	38	30	60	75.5	1.5	4	7	1.25	2035

NOTE: Additional 2"-3" clearance is recommended above the load for ease of loading and unloading the pallet lifter. \* 1 US Ton = 2,000 Lbs



**DO NOT EXCEED CAPACITY!**  
See the SAFETY GUIDELINES section before using these products. Pages 92-95.



## PLAF ADJUSTABLE FORK PALLET LIFTER

### FEATURES

- This style of lifter is designed to lift and carry palletized loads efficiently with an overhead crane.
- Supplied standard with manually adjustable forks that allow the lifter to handle various pallet sizes.
- Counter balanced to hang level when unloaded.
- Easily maintained low headroom design.
- The bail is a lower headroom design and is positioned to avoid side loading the crane hook.
- Engineered and manufactured to ASME B30.20 & BTH-1 Design Category B Service Class 2.
- 100% of ALL Peerless Pallet Lifters are Proof-Tested to 125% capacity and certificates supplied at No Additional Charge.

### OPTIONS

- Larger throat openings
- Greater outside fork widths
- Additional sizes and capacities available

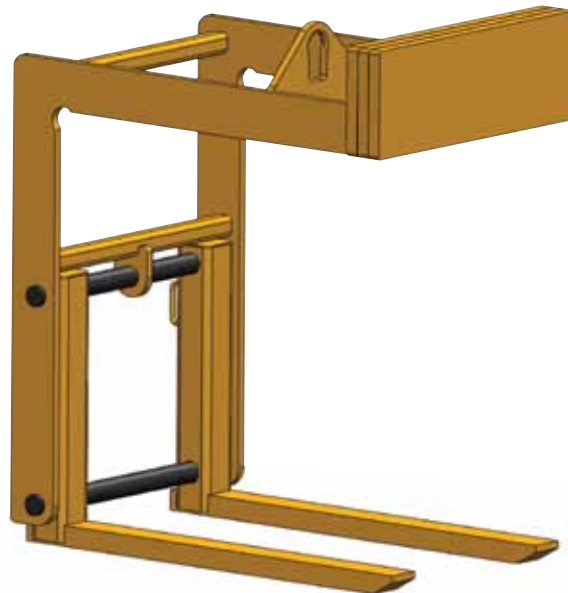
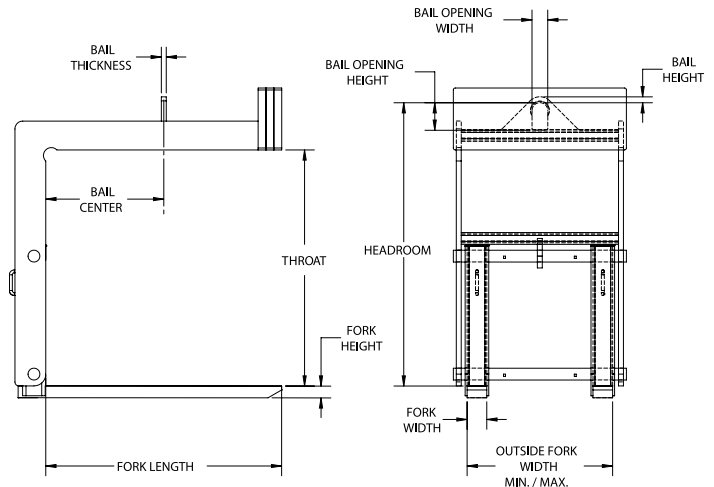

Model #	Capacity (US Tons)*	Dimensions (Inches)											Weight (Lbs.)
		Fork Length	Fork Width	Fork Height	Outside Fork Width Min/Max	Bail Center	Throat Opening Height	Head-room	Bail Height	Bail Opening Width	Bail Opening Height	Bail Thick-ness	
PLAF-1-36	1	36	2	2	16/38	18	48	58	0.88	3	5	0.75	900
PLAF-1-42	1	42	2	2	16/38	21	48	58	0.88	3	5	0.75	1025
PLAF-1-48	1	48	2	2	16/38	24	48	59	0.88	3	5	0.75	1050
PLAF-1.5-36	1.5	36	3	2	16/38	18	48	59	0.88	3	5	0.75	1140
PLAF-1.5-42	1.5	42	3	2	16/38	21	48	59	0.88	3	5	0.75	1215
PLAF-1.5-48	1.5	48	3	2	16/38	24	48	60	0.88	3	5	0.75	1285
PLAF-2-36	2	36	3	2	16/38	18	48	60	0.88	3	5	0.75	1325
PLAF-2-42	2	42	4	2	16/38	21	48	60	0.88	3	5	0.75	1435
PLAF-2-48	2	48	4	2	16/38	24	48	60	0.88	3	5	0.75	1460
PLAF-3-42	3	42	4.5	2.5	16/38	21	48	61.5	1.25	3	5	1	1690
PLAF-3-48	3	48	4.5	2.5	16/38	24	48	61.5	1.25	3	5	1	1850
PLAF-3-54	3	54	4.5	2.5	16/38	27	48	63	1.25	3	5	1	2700
PLAF-4-48	4	48	5	3	16/38	24	48	64	1.25	3	5	1	2160
PLAF-4-60	4	60	5	3	16/38	30	60	76	1.25	3	5	1	3025
PLAF-5-48	5	48	5	3	16/38	24	48	65	1.5	4	7	1.25	2520
PLAF-5-60	5	60	5	3	16/38	30	60	77	1.5	4	7	1.25	2960

NOTE: Additional 2"-3" clearance is recommended above the load for ease of loading and unloading the pallet lifter. \* 1 US Ton = 2,000 Lbs



**DO NOT EXCEED CAPACITY!**  
See the SAFETY GUIDELINES section before using these products. Pages 92-95.



## ADJUSTABLE FORK PALLET LIFTER w/HAND WHEEL

### FEATURES

- This style of lifter is designed to lift and carry palletized loads efficiently with an overhead crane.
- Supplied standard with a hand wheel to adjust forks to allow the lifter to handle various pallet sizes.
- Counter balanced to hang level when unloaded.
- Easily maintained low headroom design.
- The bail is a lower headroom design and is positioned to avoid side loading the crane hook.
- Engineered and manufactured to ASME B30.20 & BTH-1 Design Category B Service Class 2.
- 100% of ALL Peerless Pallet Lifters are Proof-Tested to 125% capacity and certificates supplied at No Additional Charge.

### OPTIONS

- Larger throat openings
- Greater outside fork widths
- Additional sizes and capacities available

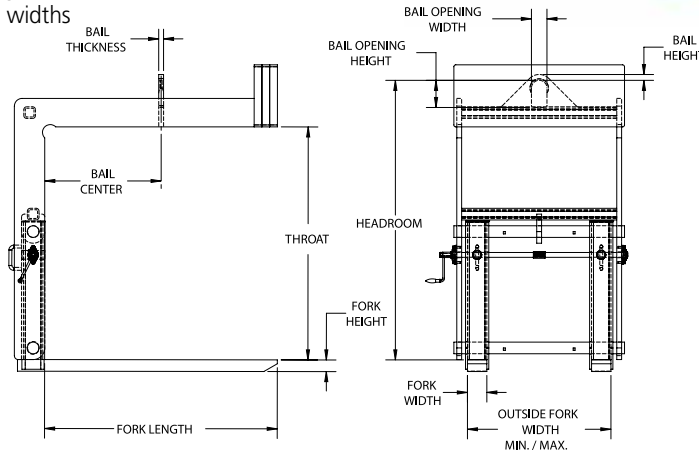

PALLET LIFTERS

Model #	Capacity (US Tons)*	Dimensions (Inches)											Weight (Lbs.)
		Fork Length	Fork Width	Fork Height	Outside Fork Width Min/Max	Bail Center	Throat Opening Height	Headroom	Bail Height	Bail Opening Width	Bail Opening Height	Bail Thickness	
PLHW-1-36	1	36	2	2	16/38	18	48	58	0.88	3	5	0.75	950
PLHW-1-42	1	42	2	2	16/38	21	48	58	0.88	3	5	0.75	1075
PLHW-1-48	1	48	2	2	16/38	24	48	59	0.88	3	5	0.75	1100
PLHW-1.5-36	1.5	36	3	2	16/38	18	48	59	0.88	3	5	0.75	1190
PLHW-1.5-42	1.5	42	3	2	16/38	21	48	59	0.88	3	5	0.75	1265
PLHW-1.5-48	1.5	48	3	2	16/38	24	48	60	0.88	3	5	0.75	1335
PLHW-2-36	2	36	3	2	16/38	18	48	60	0.88	3	5	0.75	1275
PLHW-2-42	2	42	4	2	16/38	21	48	60	0.88	3	5	0.75	1485
PLHW-2-48	2	48	4	2	16/38	24	48	60	0.88	3	5	0.75	1510
PLHW-3-42	3	42	4.5	2.5	16/38	21	48	61.5	1.25	3	5	1	1740
PLHW-3-48	3	48	4.5	2.5	16/38	24	48	61.5	1.25	3	5	1	1900
PLHW-3-54	3	54	4.5	2.5	16/38	27	48	63	1.25	3	5	1	2750
PLHW-4-48	4	48	5	3	16/38	24	48	64	1.25	3	5	1	2210
PLHW-4-60	4	60	5	3	16/38	30	60	76	1.25	3	5	1	3075
PLHW-5-48	5	48	5	3	16/38	24	48	65	1.5	4	7	1.25	2570
PLHW-5-60	5	60	5	3	16/38	30	60	77	1.5	4	7	1.25	3010

NOTE: Additional 2"-3" clearance is recommended above the load for ease of loading and unloading the pallet lifter. \* 1 US Ton = 2,000 Lbs



**DO NOT EXCEED CAPACITY!**  
See the SAFETY GUIDELINES section before using these products. Pages 92-95.

## PLHD FIXED FORK HEAVY DUTY PALLET LIFTER

### FEATURES

- This style of lifter is designed with a double frame to lift and carry heavy palletized loads efficiently with an overhead crane.
- Counter balanced to hang level when unloaded.
- Easily maintained low headroom design.
- The bail is a lower headroom design and is positioned to avoid side loading the crane hook.
- Engineered and manufactured to ASME B30.20 & BTH-1 Design Category B Service Class 2.
- 100% of ALL Peerless Pallet Lifters are Proof-Tested to 125% capacity and certificates supplied at No Additional Charge.

### OPTIONS

- Larger throat openings
- Greater outside fork widths
- Additional sizes and capacities available

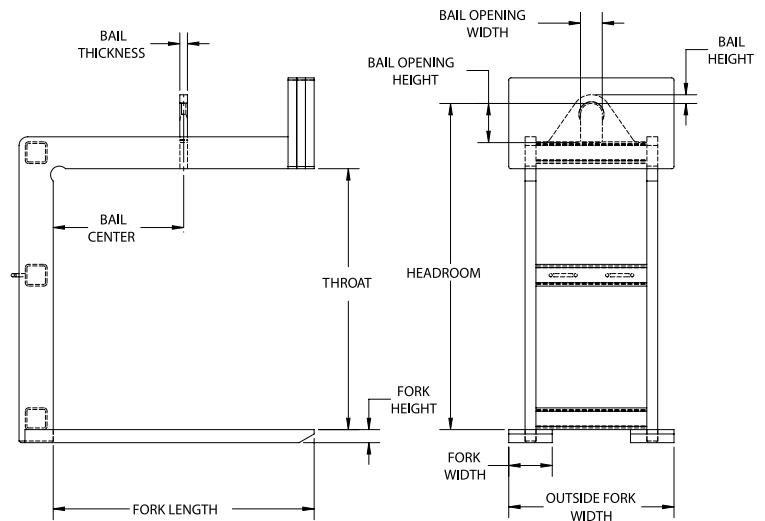

Model #	Capacity (US Tons)*	Dimensions (Inches)											Weight (Lbs.)
		Fork Length	Fork Width	Fork Height	Outside Fork Width	Bail Center	Throat Opening Height	Head-room	Bail Height	Bail Opening Width	Bail Opening Height	Bail Thickness	
PLHD-7.5-48	7.5	48	6	3	30	24	48	65	1.50	4	7	1.50	2485
PLHD-7.5-60	7.5	60	8	3	38	30	60	79	1.50	4	7	1.50	3120
PLHD-10-48	10	48	8	3	30	24	48	69	2	5	9	1.75	2540
PLHD-10-60	10	60	10	3	38	30	60	81	2	5	9	1.75	4025
PLHD-15-48	15	48	10	3	38	24	60	84	2	5	9	1.75	2925
PLHD-15-60	15	60	10	3.5	38	30	60	75	2	5	9	1.75	4940
PLHD-20-60	20	60	10	4	38	30	60	88	2.25	6	12	2	5590
PLHD-20-72	20	72	12	4	44	36	60	88	2.25	6	12	2	6300

NOTE: Additional 2"-3" clearance is recommended above the load for ease of loading and unloading the pallet lifter. \* 1 US Ton = 2,000 Lbs



**WARNING**

DO NOT EXCEED CAPACITY!  
See the SAFETY GUIDELINES section before using these products. Pages 92-95.



## ADJUSTABLE FORK HEAVY DUTY PALLET LIFTER

### FEATURES

- This style of lifter is designed with a double frame and forged forks to lift and carry heavy palletized loads efficiently with an overhead crane.
- Supplied standard with manually adjustable forks that allow the lifter to handle various pallet sizes.
- Counter balanced to hang level when unloaded.
- Easily maintained low headroom design.
- The bail is a lower headroom design and is positioned to avoid side loading the crane hook.
- Engineered and manufactured to ASME B30.20 & BTH-1 Design Category B Service Class 2.
- 100% of ALL Peerless Pallet Lifters are Proof-Tested to 125% capacity and certificates supplied at No Additional Charge.

### OPTIONS

- Larger throat openings
- Greater outside fork widths
- Additional sizes and capacities available

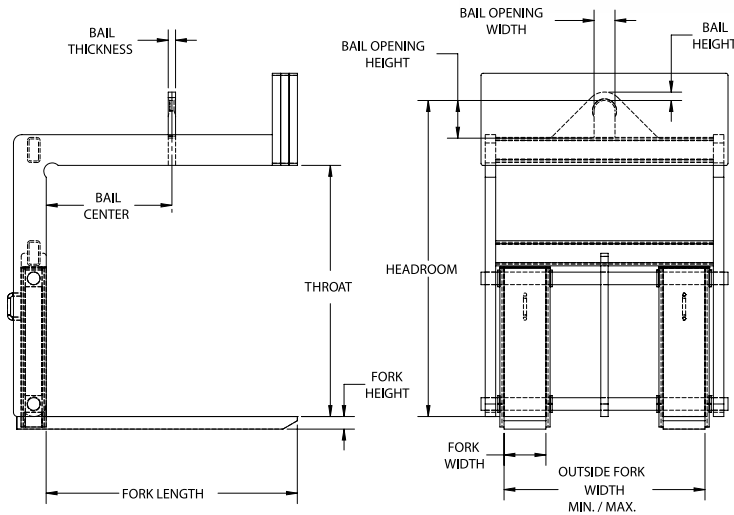

PALLET LIFTERS

Model #	Capacity (US Tons)*	Dimensions (Inches)											Weight (Lbs.)
		Fork Length	Fork Width	Fork Height	Outside Fork Width Min/Max	Bail Center	Throat Opening Height	Headroom	Bail Height	Bail Opening Width	Bail Opening Height	Bail Thickness	
PLHA-7.5-48	7.5	48	6	3	16/48	24	48	61	1.50	4	7	1.50	3200
PLHA-7.5-60	7.5	60	8	3	20/48	30	60	74	1.50	4	7	1.50	4300
PLHA-7.5-72	7.5	72	10	3	24/48	36	60	76	1.50	4	7	1.50	4900
PLHA-10-48	10	48	8	3	20/48	24	48	64	2	5	9	1.75	3800
PLHA-10-60	10	60	10	3	24/48	30	60	76	2	5	9	1.75	5600
PLHA-10-72	10	72	10	3.5	24/48	36	60	76	2	5	9	1.75	6400
PLHA-12.5-48	12.5	48	8	3	16/48	24	48	78	2	5	9	1.75	5100
PLHA-12.5-60	12.5	60	10	3	24/48	30	60	78	2	5	9	1.75	6200
PLHA-12.5-72	12.5	72	10	3.5	24/48	36	60	78	2	5	9	1.75	7200

NOTE: Additional 2"-3" clearance is recommended above the load for ease of loading and unloading the pallet lifter. \* 1 US Ton = 2,000 Lbs



**DO NOT EXCEED CAPACITY!**  
See the SAFETY GUIDELINES section before using these products. Pages 92-95.

## PLAH ADJUSTABLE FORK HEAVY DUTY PALLET LIFTER w/Hand Wheel

### FEATURES

- This style of lifter is designed with a double frame and forged forks to lift and carry heavy palletized loads efficiently with an overhead crane.
- Supplied standard with a hand wheel to adjust forks to allow the lifter to handle various pallet sizes.
- Counter balanced to hang level when unloaded.
- Easily maintained low headroom design.
- The bail is a lower headroom design and is positioned to avoid side loading the crane hook.
- Engineered and manufactured to ASME B30.20 & BTH-1 Design Category B Service Class 2.
- 100% of ALL Peerless Pallet Lifters are Proof-Tested to 125% capacity and certificates supplied at No Additional Charge.

### OPTIONS

- Larger throat openings
- Greater outside fork widths
- Additional sizes and capacities available

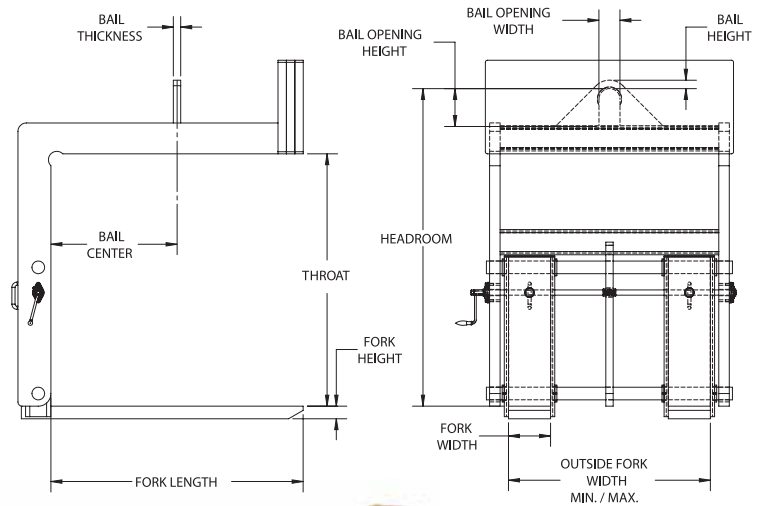

Model #	Capacity (US Tons)*	Dimensions (Inches)											Weight (Lbs.)
		Fork Length	Fork Width	Fork Height	Outside Fork Width Min/Max	Bail Center	Throat Opening Height	Head-room	Bail Height	Bail Opening Width	Bail Opening Height	Bail Thickness	
PLAH-7.5-48	7.5	48	6	3	16/48	24	48	66	1.50	4	7	1.50	3350
PLAH-7.5-60	7.5	60	8	3	20/48	30	60	77.5	1.50	4	7	1.50	4550
PLAH-7.5-72	7.5	72	10	3	24/48	36	60	80	1.50	4	7	1.50	5050
PLAH-10-48	10	48	8	3	20/48	24	48	65.5	2	5	9	1.75	3950
PLAH-10-60	10	60	10	3	24/48	30	60	77.5	2	5	9	1.75	5750
PLAH-10-72	10	72	10	3.5	24/48	36	60	82	2	5	9	1.75	6550
PLAH-12.5-48	12.5	48	8	3	16/48	24	48	82	2	5	9	1.75	5250
PLAH-12.5-60	12.5	60	10	3	24/48	30	60	82	2	5	9	1.75	6350
PLAH-12.5-72	12.5	72	10	3.5	24/48	36	60	82	2	5	9	1.75	7350
PLAH-15-60	15	60	10	3.5	24/48	30	60	82	2	5	9	1.75	7050
PLAH-15-72	15	72	12	3.5	28/48	36	60	82.5	2	5	9	1.75	8450

NOTE: Additional 2"-3" clearance is recommended above the load for ease of loading and unloading the pallet lifter. \* 1 US Ton = 2,000 Lbs



**DO NOT EXCEED CAPACITY!**  
See the SAFETY GUIDELINES section before using these products. Pages 92-95.

## PLWL WHEELED PALLET LIFTER

### FEATURES

- This style of lifter is designed to lift and carry palletized loads efficiently with an overhead crane.
- Wheeled design allows for ease of movement to the load and dual lift points allow the lifter to hang level when unloaded.
- Easily maintained low headroom design.
- Engineered and manufactured to ASME B30.20 & BTH-1 Design Category B Service Class 2.
- 100% of ALL Peerless Pallet Lifters are Proof-Tested to 125% capacity and certificates supplied at No Additional Charge.

### OPTIONS

- Larger throat openings
- Greater outside fork widths
- Additional sizes and capacities available

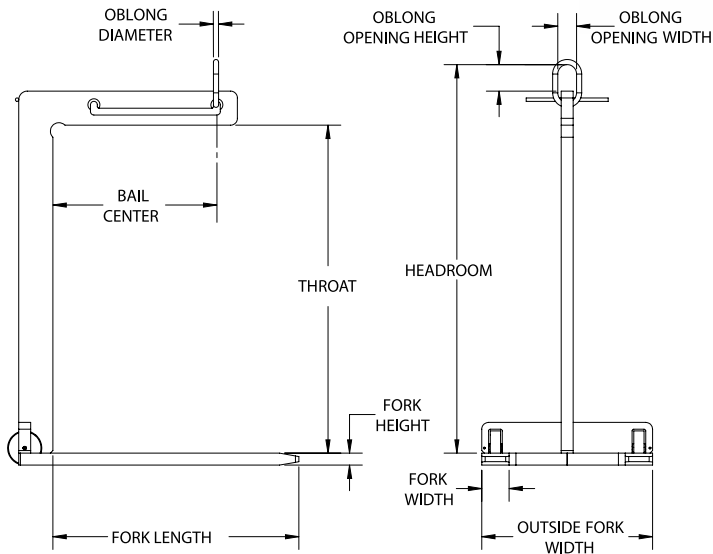

PALLET LIFTERS

Model #	Capacity (US Tons)*	Dimensions (Inches)										Weight (Lbs.)
		Fork Length	Fork Width	Fork Height	Outside Fork Width	Bail Center	Throat Opening Height	Head-room	Oblong ML Diameter	Oblong ML Opening Width	Oblong ML Opening Height	
PLWL-1-48	1	36	2	1.75	25	24	48	53	0.63	3	6	255
PLWL-2-48	2	36	4	1.75	25	24	48	57	0.63	3	6	435

NOTE: Additional 2"-3" clearance is recommended above the load for ease of loading and unloading the pallet lifter.

\* 1 US Ton = 2,000 Lbs



**DO NOT EXCEED CAPACITY!**  
See the SAFETY GUIDELINES section before using these products. Pages 92-95.

## PLLW LIGHTWEIGHT PALLET LIFTER

### FEATURES

- This style of lifter is designed to lift and carry palletized loads efficiently with an overhead crane.
- Lightweight design allows for ease of movement to the load and dual lift points allow the lifter to hang level when unloaded.
- Easily maintained low headroom design.
- Engineered and manufactured to ASME B30.20 & BTH-1 Design Category B Service Class 2.
- 100% of ALL Peerless Pallet Lifters are Proof-Tested to 125% capacity and certificates supplied at No Additional Charge.

### OPTIONS

- Larger throat openings
- Greater outside fork widths
- Additional sizes and capacities available

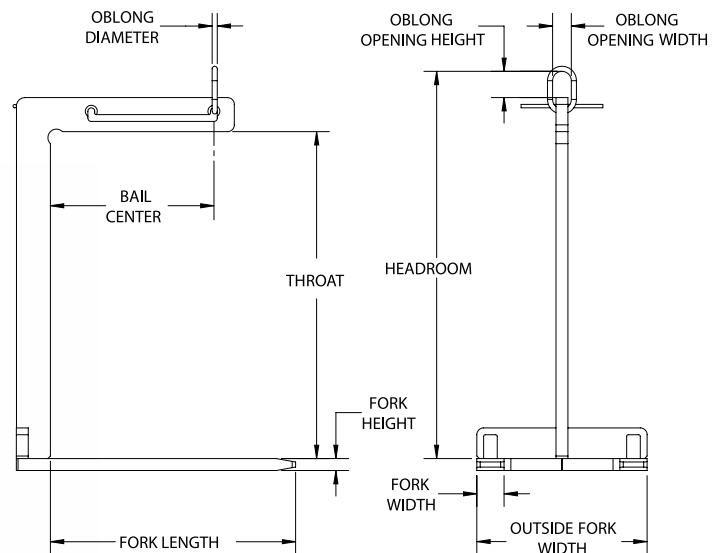
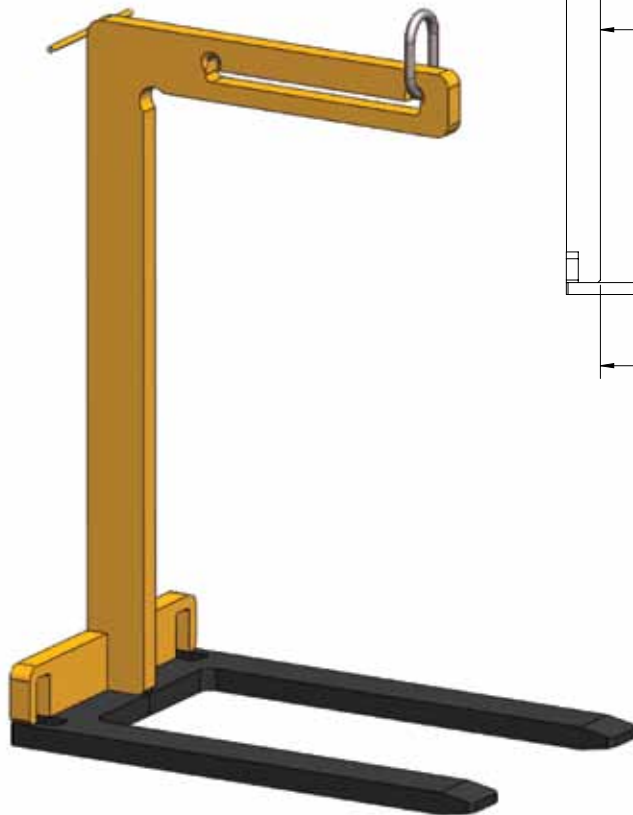

Model #	Capacity (US Tons)*	Dimensions (Inches)										Weight (Lbs.)
		Fork Length	Fork Width	Fork Height	Outside Fork Width	Bail Center	Throat Opening Height	Head-room	Oblong ML Diameter	Oblong ML Opening Width	Oblong ML Opening Height	
PLLW-1-48	1	36	2	1.75	25	24	48	53	0.63	3	6	245
PLLW-2-48	2	36	4	1.75	25	24	48	57	0.63	3	6	425
PLLW-3-48	3	36	5	2	27	24	48	62	1	3.5	7	625

NOTE: Additional 2"-3" clearance is recommended above the load for ease of loading and unloading the pallet lifter.

\* 1 US Ton = 2,000 Lbs



**DO NOT EXCEED CAPACITY!**  
See the SAFETY GUIDELINES section before using these products. Pages 92-95.



**PEERLESS**<sup>®</sup>  
A KITO GROUP COMPANY

THE INDUSTRY LEADER IN

# WELDED CHAIN SLINGS

Welded Chain Slings are fabricated to meet your specific lifting needs.

Options include:

- Sling Type – Single, Double, Triple, Quad or Adjustable.
- Chain Grade & Size – 100 (9/32" – 1"), 80 (9/32" – 2"), 63 (9/32" – 1"), Normalized Proof Coil (for acid dip pickling applications), Inconel, Nitronic 50, Monel 400, Carpenter 20/Alloy 20 and Stainless steels: 316, 304, 308.
- Attachments\*

Every welded chain sling is registered and documented for inspection. Mechanical chain slings available on request with similar options. All chain slings are proof tested, tagged and test cert provided. Inspection and repair service also available.

Common Attachments\* may include:

Standard sling, grab and foundry hooks, foundry sorting hooks or other custom bent attachments.

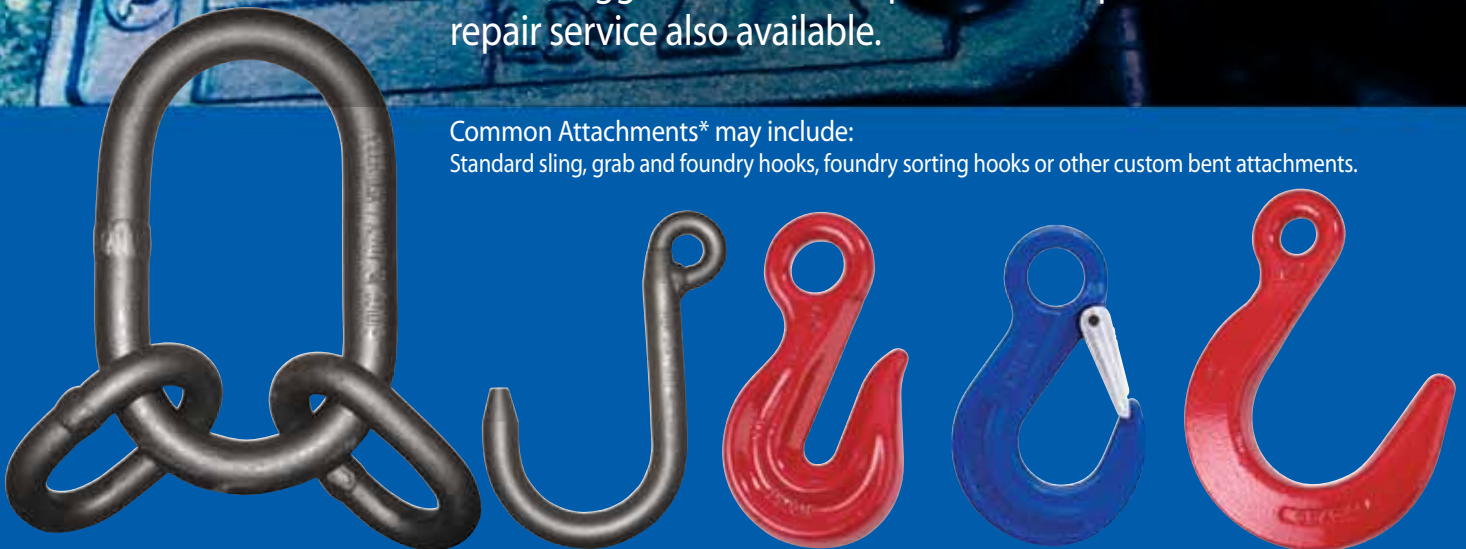





**TB**  
TELESCOPING FORK TRUCK BOOM .....Page 82



**TBP**  
TELESCOPING PIVOT FORK TRUCK BOOM .....Page 83



**FH**  
FORK TRUCK HOOK .....Page 84

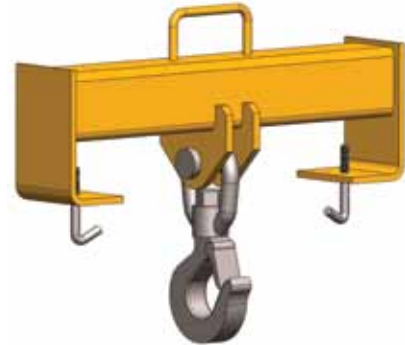

**FHB**  
FORK TRUCK HOOK BEAM .....Page 85

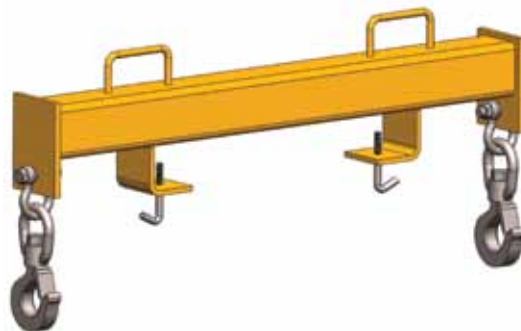

**FHBD**  
Fork Truck Double Hook Beam .....Page 86



## TELESCOPING FORK TRUCK BOOM

### FEATURES

- This style of fork truck attachment is designed to efficiently lift and carry loads with a telescoping boom with locking pin allowing for multiple hook positions.
- Supplied with standard restraining chain with grab hook and attached handle for ease of boom extension.
- 12' maximum boom reach, and supplied with standard swivel or fixed hooks.
- Engineered and manufactured in accordance to ASME B30.20 & BTH-1 Design Category B Service Class 2.
- 100% of ALL Peerless Telescoping Fork Truck Booms are Proof-Tested to 125% capacity and certificates supplied at No Additional Charge.

### OPTIONS

- Additional sizes and capacities available

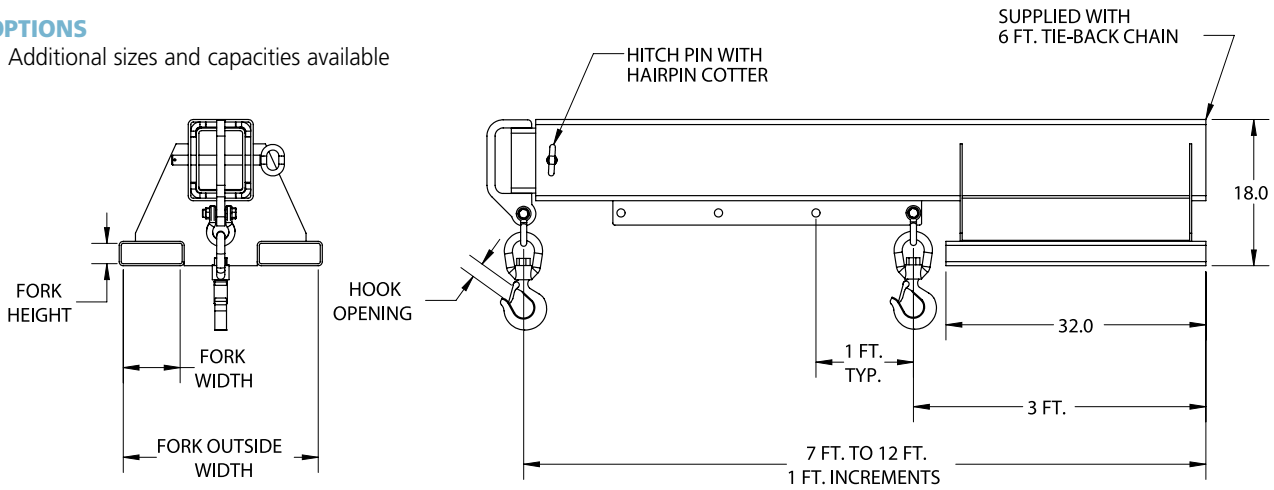

FORK TRUCK ACC.

Model # Fixed	Dimensions (Inches)					Max Capacity at Hook Position (Lbs.)							Weight (Lbs.)
	Fork Opening Height	Fork Opening Width	Fork Outside Width	Headroom	Hook Opening	3' to 6'	7'	8'	9'	10'	11'	12'	
TB-30	2.5	7	22	18	1	3000	3000	2600	2200	1900	1600	1500	490
TB-40	2.5	7	22	18	1.09	4000	3200	2600	2200	1900	1600	1500	490
TB-60	2.5	7	22	18	1.36	6000	5000	4200	3500	3000	2700	2500	565
TB-80	2.5	7	22	18	1.61	8000	7000	5700	4800	4100	3600	3100	750



**DO NOT EXCEED CAPACITY!**  
See the SAFETY GUIDELINES section before using these products. Pages 92-95.

## TBP TELESCOPING PIVOT FORK TRUCK BOOM

### FEATURES

- This style of fork truck attachment is designed to efficiently lift and carry loads with a telescoping pivot boom with locking pin allowing for multiple hook positions.
- Supplied with standard restraining chain with grab hook and attached handle for ease of boom extension.
- 12' maximum boom reach, and supplied with standard swivel or fixed hooks and can pivot to a vertical height of 6'4".
- Engineered and manufactured in accordance to ASME B30.20 & BTH-1 Design Category B Service Class 2.
- 100% of ALL Peerless Telescoping Pivot Fork Truck Booms are Proof-Tested to 125% capacity and certificates supplied at No Additional Charge.

### OPTIONS

- Additional sizes and capacities available.

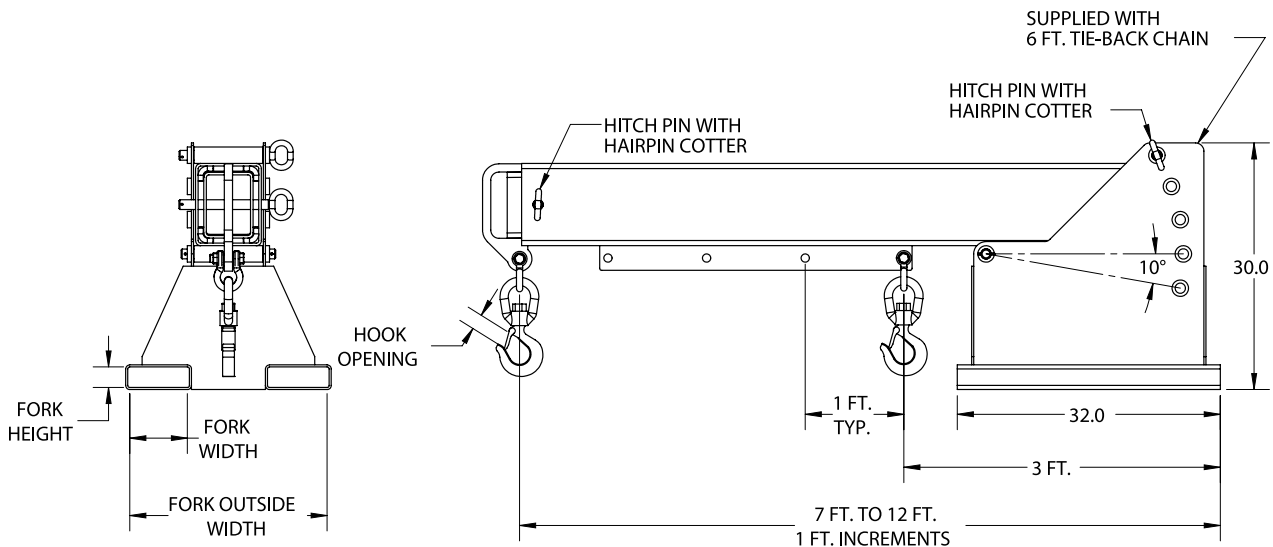

Model # Fixed	Dimensions (Inches)					Max Capacity at Hook Position (Lbs.)							Weight (Lbs.)
	Fork Opening Height	Fork Opening Width	Fork Outside Width	Headroom	Hook Opening	3' to 6'	7'	8'	9'	10'	11'	12'	
TBP-30	2.5	7	22.5	30	1	3000	3000	2600	2200	1900	1600	1500	565
TBP-40	2.5	7	22.5	30	1.09	4000	3200	2600	2200	1900	1600	1500	565
TBP-60	2.5	7	22.5	30	1.36	6000	5000	4200	3500	3000	2700	2500	680
TBP-80	2.5	7	22.5	30	1.61	8000	7000	5700	4800	4100	3600	3100	870



**DO NOT EXCEED CAPACITY!**  
See the SAFETY GUIDELINES section before using these products. Pages 92-95.



## FORK TRUCK HOOK

### FEATURES

- This style of fork truck attachment is designed to efficiently lift and carry loads on the fork of a lift truck with a single latched fixed or swivel hook.
- Easily attaches to the forks.
- Engineered and manufactured in accordance to ASME B30.20 & BTH-1 Design Category B Service Class 2.
- 100% of ALL Peerless Fork Truck Hooks are Proof-Tested to 125% capacity and certificates supplied at No Additional Charge.

### OPTIONS

- Additional sizes and capacities available

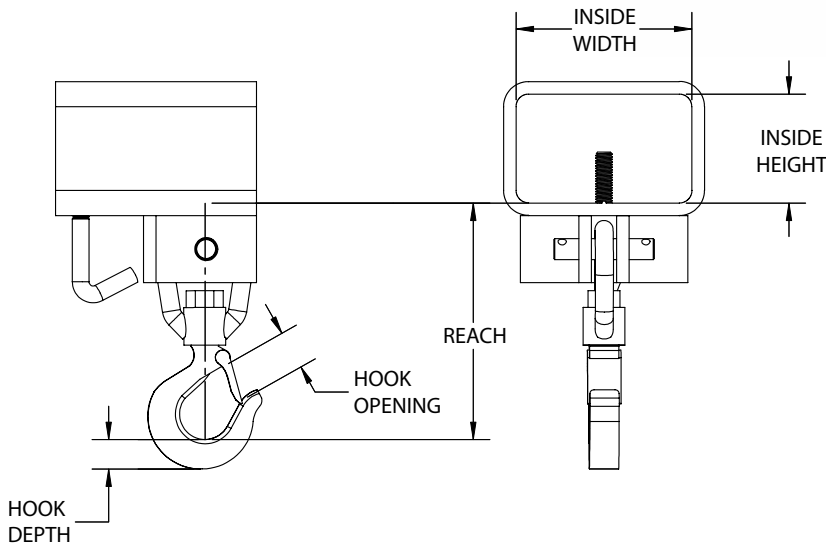
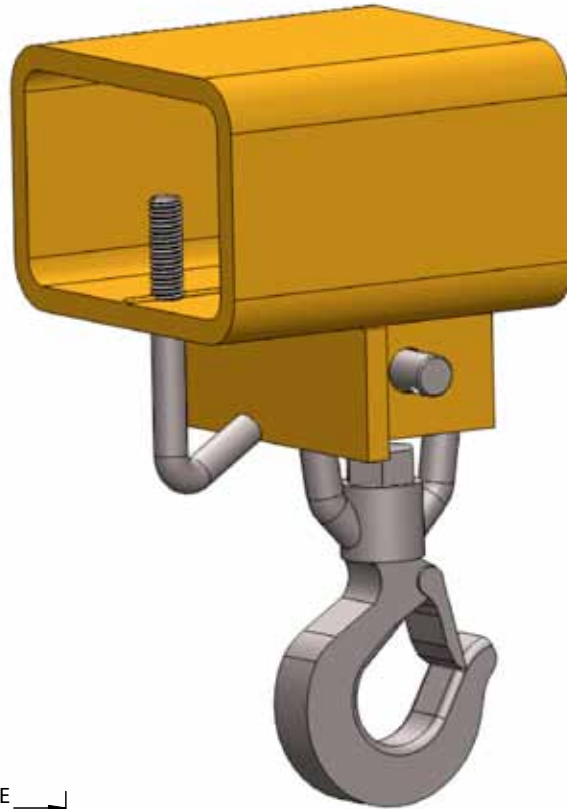

FORK TRUCK ACC.

Model # Fixed	Model # Swivel	Capacity (US Tons)*	Dimensions (Inches)					Hook Depth	Hook Opening	Weight (Lbs.)
			Inside Beam Width	Inside Beam Height	Hook Reach Fixed	Hook Reach Swivel	Hook Depth			
FH-1.5-4.5	FHS-1.5-4.5	1.5	5.25	3.25	4.69	6.56	1	1	17	
FH-1.5-5.5	FHS-1.5-5.5	1.5	6	3	4.69	6.56	1	1	22	
FH-1.5-6.5	FHS-1.5-6.5	1.5	7	3	4.69	6.56	1	1	24	

\* 1 US Ton = 2,000 Lbs



**WARNING**

DO NOT EXCEED CAPACITY!  
See the SAFETY GUIDELINES section before using these products. Pages 92-95.

## FHB FORK TRUCK HOOK BEAM

### FEATURES

- This style of fork truck attachment is designed to efficiently lift and carry loads on both forks of a lift truck with a single latched fixed or swivel hook.
- Easily attaches to the forks.
- Engineered and manufactured in accordance to ASME B30.20 & BTH-1 Design Category B Service Class 2.
- 100% of ALL Peerless Fork Truck Hooks are Proof-Tested to 125% capacity and certificates supplied at No Additional Charge.

### OPTIONS

- Additional sizes and capacities available

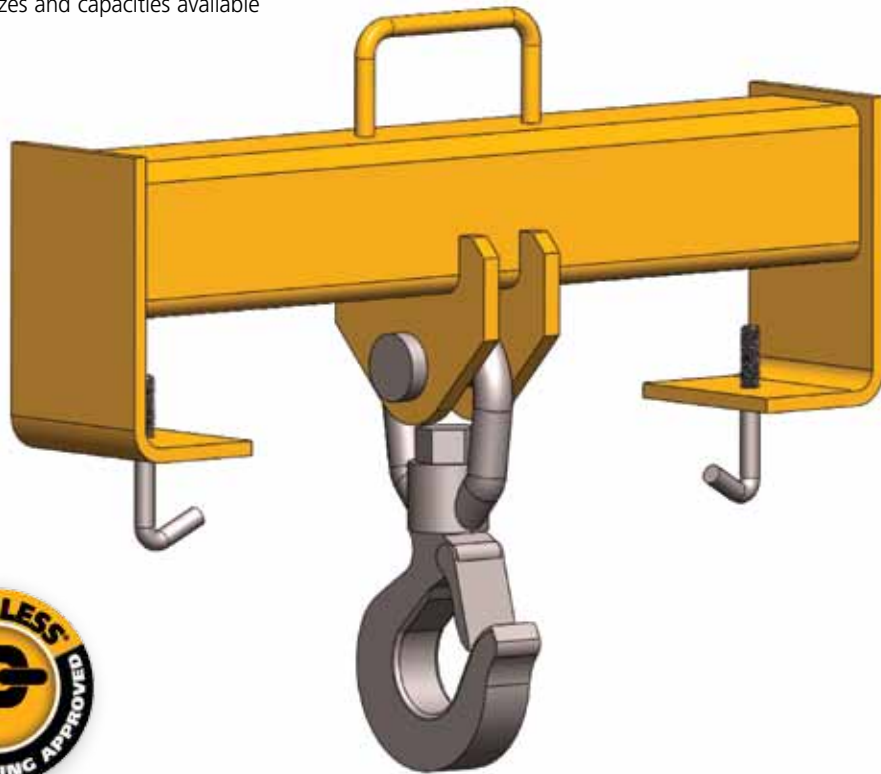
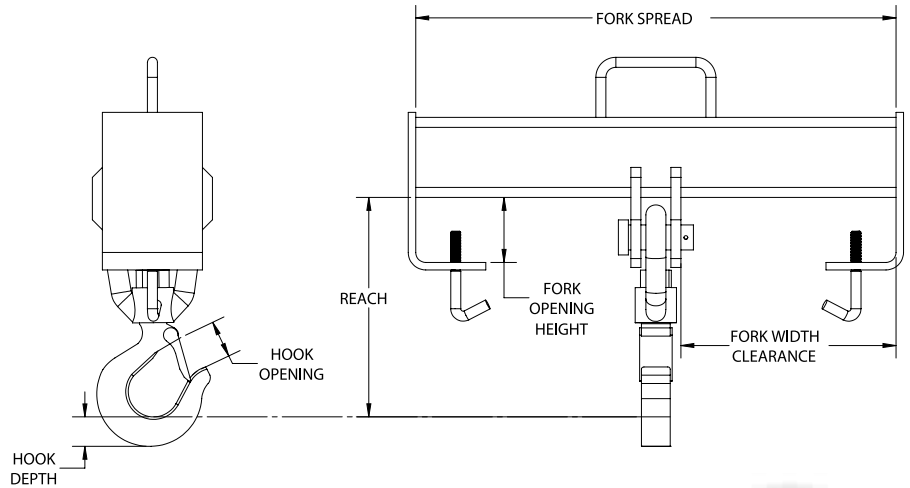

Model # Fixed	Model # Swivel	Capacity (US Tons)*	Dimensions (Inches)							Weight (Lbs.)
			Fork Spread	Fork Opening Height	Fork Width Clearance	Hook Reach Fixed	Hook Reach Swivel	Hook Depth	Hook Opening	
FHB-2-20	FHBS-2-20	2	20	3.25	9.13	7.25	8.88	1.13	1.16	25
FHB-5-24	FHBS-5-24	5	24	3.25	10.75	9.25	11.44	1.81	1.69	50
FHB-5-36	FHBS-5-36	5	36	3.25	16.75	9.25	11.44	1.81	1.69	80
FHB-7.5-36	FHBS-7.5-36	7.5	36	4.25	16.25	13.75	15.75	2.25	2.22	175
FHB-10-36	FHBS-10-36	10	36	4.25	16	14.63	16.44	2.59	2.41	190
FHB-15-36	FHBS-15-36	15	36	4.25	15.88	14.5	16.31	2.59	2.41	220

\* 1 US Ton = 2,000 Lbs

FORK TRUCK ACC.



**DO NOT EXCEED CAPACITY!**  
See the SAFETY GUIDELINES section before using these products. Pages 92-95.



## FORK TRUCK DOUBLE HOOK BEAM

### FEATURES

- This style of fork truck attachment is designed to efficiently lift and carry loads on both forks of a lift truck with two latched swivel hooks.
- Easily attaches to the forks.
- Engineered and manufactured in accordance to ASME B30.20 & BTH-1 Design Category B Service Class 2.
- 100% of ALL Peerless Fork Truck Hooks are Proof-Tested to 125% capacity and certificates supplied at No Additional Charge.

### OPTIONS

- Additional sizes and capacities available

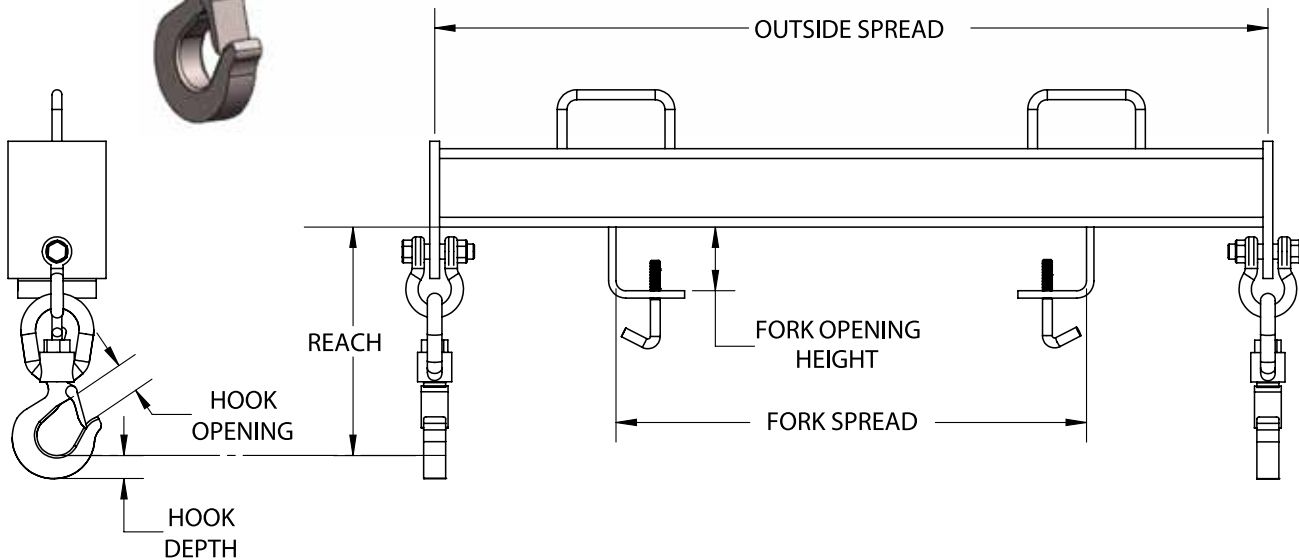
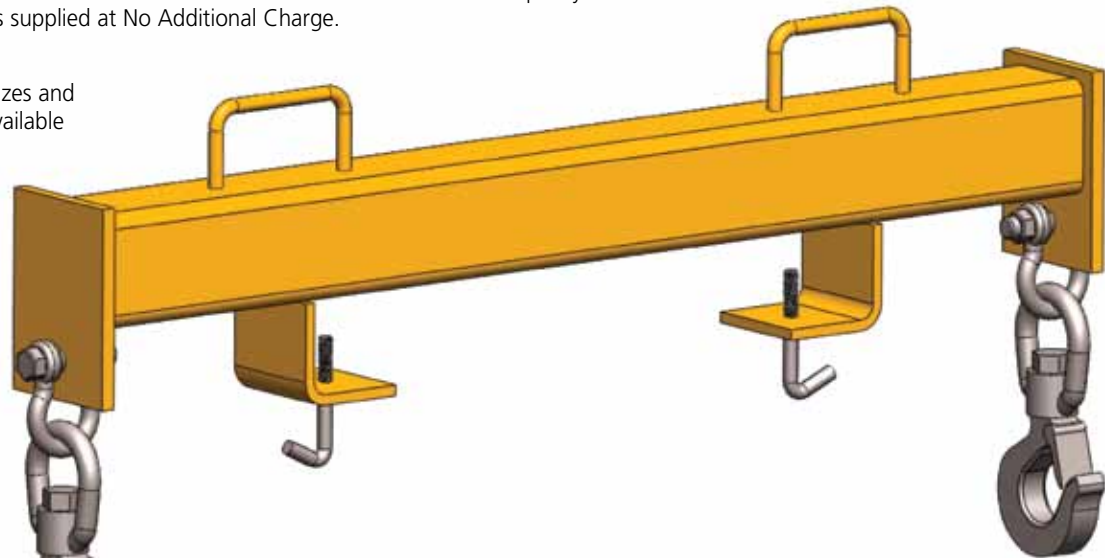

FORK TRUCK ACC.

Model #	Capacity (US Tons)*	Dimensions (Inches)						Weight (Lbs.)
		Outside Beam Spread	Fork Spread	Fork Opening Height	Hook Reach	Hook Depth	Hook Opening	
FHBD-2-20	2	20	6.63	3.25	10.38	1.44	0.91	66
FHBD-5-24	5	24	9.38	3.25	11.66	1.44	1.36	75

\* 1 US Ton = 2,000 Lbs



**DO NOT EXCEED CAPACITY!**  
See the SAFETY GUIDELINES section before using these products. Pages 92-95.



## **MSHD**

Material Stands Heavy Duty.....Page 88

## **MBHD**

Material Baskets Heavy Duty.....Page 90



**DO NOT EXCEED CAPACITY!**  
See the SAFETY GUIDELINES section before using these products. Pages 92-95.



## MATERIAL STANDS HEAVY DUTY

### FEATURES

- This style of material handling equipment is designed to hold product at a preset work height.
- Designed and manufactured in pairs to meet your specific height and capacity requirement.
- Standard heavy duty welded steel design.
- Standard rated capacity labels.
- Engineered and manufactured in accordance to ASME B30.20 & BTH-1 Design Category B Service Class 2.

### OPTIONS

- Fork lift transport pockets
- Spring loaded caster wheels
- Protective padding





# MATERIAL STANDS

Custom Application Form



**PEERLESS**  
A KITO GROUP COMPANY

For pricing information: Fax completed form & contact info to (800)-356-1149

## LOAD INFORMATION:

Describe the material you are planning to set on the stands: \_\_\_\_\_

Does the Material Require Protective Lining to Prevent Damage:  Yes  No

Is the Material Hot:  Yes  No

If Yes:

Max Temp \_\_\_\_\_

Required Contact Time with Material: \_\_\_\_\_

Min Cool Down Time: \_\_\_\_\_

Material Dimensions:

	Min (in)	Max (in)
Height	_____	_____
Width	_____	_____
Length	_____	_____
Weight	_____	_____

## MATERIAL STAND INFORMATION:

Required Height: \_\_\_\_\_

Required Width: \_\_\_\_\_

Required Capacity: \_\_\_\_\_

Spring Loaded Caster Wheels (specify floor surface): \_\_\_\_\_

Fork Lift Transport Pockets (specify dimensions):

Length: \_\_\_\_\_

Width: \_\_\_\_\_

Height: \_\_\_\_\_

Please provide pertinent application information not supplied above (*extreme product or operating temperature, extreme environmental conditions such as temperature or moisture, space or headroom restrictions, additional specifications*): \_\_\_\_\_

\_\_\_\_\_  
\_\_\_\_\_  
\_\_\_\_\_



## MATERIAL BASKETS HEAVY DUTY

### FEATURES

- This style of material handling equipment is designed to lift, transport and contain product effectively and efficiently.
- Designed and manufactured to meet your specific application requirements.
- Standard heavy duty welded steel design.
- Standard expanded metal or solid side walls and heavy duty hinged door.
- Standard rated capacity labels.
- Engineered and manufactured in accordance to ASME B30.20 & BTH-1 Design Category B Service Class 2.
- 100% of ALL Peerless Material Baskets are Proof-Tested to 125% capacity and certificates supplied at No Additional Charge.

### OPTIONS

- Fork lift transport pockets
- Caster wheels
- Protective padding
- Chain top rigging
- Wire rope top rigging



# MATERIAL BASKETS

Custom Application Form



# PEERLESS<sup>®</sup>

A KITCO GROUP COMPANY

For pricing information: Fax completed form & contact info to (800)-356-1149

## LOAD INFORMATION:

Describe the material you are planning to place in the basket: \_\_\_\_\_

Will the Material be placed in the Center of the Basket:  Yes  No  
If No, Please Provide a Drawing or Sketch Indicating the Load Center.

Material Dimensions:		
	Min (in)	Max (in)
Height	_____	_____
Width	_____	_____
Length	_____	_____
Weight	_____	_____

Does the Material Require Protective Lining to Prevent Damage:  Yes  No

## MATERIAL BASKET INFORMATION:

Required Wall Height: \_\_\_\_\_ Width: \_\_\_\_\_ Depth: \_\_\_\_\_ Capacity: \_\_\_\_\_

Door:

Specify Location:  End  Side

Specify Swing:  Right  Left

Other: \_\_\_\_\_

Wall Material:

Solid  Expanded Metal  Open Frame

Other: \_\_\_\_\_

Crane Attachment:

Chain Top Rigging  Wire Rope Rigging  Lifting Beam  Lifting Bracket

Caster Wheels (specify floor surface): \_\_\_\_\_

Fork Lift Transport Pockets (specify dimensions):

Length: \_\_\_\_\_ Width: \_\_\_\_\_ Height: \_\_\_\_\_

Maximum Fork Outside Width: \_\_\_\_\_

Please provide any pertinent application information not supplied above (*extreme product or operating temperature, extreme environmental conditions such as temperature or moisture, space restrictions, additional specifications*): \_\_\_\_\_

# SAFETY GUIDELINES

## INDUSTRY STANDARDS

The American Society of Mechanical Engineers (ASME) developed standards that apply specifically to the devices Peerless Industrial Group designs and manufacturers. These standards serve as a guide to government authorities, manufacturers, purchasers and operators of below-the-hook lifting devices.

### ASME B30.20-2013

- Provides detailed information on the classifications, marking, construction, installation, inspection, testing, maintenance and operation of below-the-hook lifting devices.

### ASME BTH-1-2017

- Provides detailed information on the design criteria of below-the-hook lifting devices.



## MARKINGS, IDENTIFICATION & GENERAL CONSTRUCTION

The rated load of the lifting device is visibly marked on the main structure of the device, as well as on a tag attached to the lifter. If the below-the-hook lifting device consists of individually detachable lifters, then each of the individual lifters shall be marked and tagged with their individual rated loads.

All Peerless Industrial Group below-the-hook lifting devices are tagged with the following information:

- Manufacturer's name and address
- Serial number
- Lifter weight, if over 100 lbs. (45 kg)
- Cold current (amps) (when applicable)
- Rated voltage (when applicable)
- Rated load
- Manufacture date
- ASME BTH-1 Design category
- ASME BTH-1 Service class

All Peerless structural and mechanical lifting devices are designed and manufactured by qualified personnel. Peerless designs are in accordance with ASME BTH-1 and take into consideration the stresses that result from the application of the rated load along with the weight of the actual lifter and are designed to ASME BTH-1 Design Category B. Service Class is determined by taking into consideration the fatigue life criteria based on the expected number of load cycles.

## DESIGN CATEGORY

Design category B shall be utilized when the size, scale, and variation of loads applied to the lifter are not always predictable or clearly defined, and where the environmental and loading conditions vary or could be severe.

## SERVICE CLASS

- Service Class is determined by the specified fatigue life of the lifter.
  - Service Class 0 is 0 to 20,000 load cycles.
  - Service Class 1 is 20,001 to 100,000 load cycles.
  - Service Class 2 is 100,001 to 500,000 load cycles.
  - Service Class 3 is 500,001 to 2,000,000 load cycles.
  - Service Class 4 is over 2,000,000 load cycles

## SERVICE CLASS LIFE

Cycles Per Day	Desired Life (Years)				
	1	5	10	20	30
5	0	0	0	1	1
10	0	0	1	1	2
25	0	1	1	2	2
50	0	1	2	2	3
100	1	2	2	3	3
200	1	2	3	3	4
300	2	3	3	4	4
750	2	3	4	4	4
1,000	2	3	4	4	4

All welding shall be in accordance with ANSI/AWS D14.1 and ASME BTH-1

Exposed moving parts such as gears, projecting shafts and chain drives that constitute a hazard under normal operating conditions are guarded.

Electrical equipment and wiring shall comply with ANSI/NFPA 70 and ASME BTH-1.

FOR INFORMATION ON MODIFICATIONS OR REPAIRS TO YOUR LIFTING DEVICE, CONTACT PEERLESS INDUSTRIAL GROUP TO ENSURE COMPLIANCE WITH THE CURRENT ASME STANDARDS

## PROOF TEST

100% OF ALL PEERLESS BELOW-THE-HOOK LIFTING DEVICES ARE PROOF-TESTED TO 125% CAPACITY AND CERTIFICATES SUPPLIED AT NO ADDITIONAL CHARGE.

### Requirements & Recommendations:

Requirements of the ASME standard are noted by the word **shall**.

Recommendations of the ASME standard are noted by the word **should**.

## OPERATION PRACTICES FOR LIFTING DEVICES

Below-the-hook lifting devices shall only be operated by the following qualified personnel:

- Personnel designated to operate the lifter.
- Trainees who are under the direct supervision of designated personnel.
- Personnel designated to maintenance and/or conduct testing on the lifter.
- Personnel designated to inspect the lifter.

The below-the-hook lifting device shall not be overloaded beyond its manufactured rated capacity nor shall it be utilized to handle any load that it was not designed to handle.

When rigging is utilized in conjunction with the lifter, the operator shall ensure that it is not kinked and the multiple part lines are not twisted around each other.

The operator shall ensure that the load is correctly distributed for the lifter prior to the lift.

The operator shall ensure that the temperature of the load does not exceed the maximum allowable limits of the lifting device.

The operator shall ensure that the lifter is moved into place over the load in such a way as to minimize swinging.

The operator shall ensure that sudden acceleration or deceleration of the load is prevented.

The operator shall ensure that the lifter and the load do not come into contact with any obstruction.

The operator shall ensure that the load is not transported over people.

The operator shall ensure that the lifter is not utilized for side pulls or sliding the load unless explicitly authorized by a qualified person.

The operator shall ensure that suspended loads are not left unattended.

The operator shall ensure that no person rides the load or the lifter.

The operation of the lifter shall be observed prior to and during a shift. Any observed deficiency in the lifter shall be examined by designated personnel. Any deficiency that constitutes a hazard shall be removed from service and tagged "Out of Service". All hazardous deficiencies shall be reported to qualified personnel for evaluation.

All loads shall be guided in a manner to avoid endangering any part of the body as it is lowered or accidentally dropped.

### Miscellaneous Operating Practices

An operator shall not utilize a below-the-hook lifter that has an "out of service" tag or has been designated as non-functioning.

Only designated personnel shall be given the authority to remove "Out of service" tags on lifting devices.

When not in use the below-the-hook device should be stored in an assigned location.

Lifter markings and tags shall not be removed or damaged. Lifter markings and tags that are missing or illegible shall be replaced.

## INSPECTION

### Initial Inspection:

Prior to initial use, all new, altered, modified, or repaired lifting devices shall be inspected by a qualified person to ensure compliance with the provisions of the ASME B30.20 standard.

### Inspection Intervals:

Below-the-hook lifters in regular service require three general types of inspection classification procedures; every lift, frequent, and periodic. The intervals for inspection are determinant upon the severity of use of the below-the-hook device, the extent of the exposure to wear and tear, as well as any history of malfunction experienced by the lifter.

### Every Lift Inspection:

A visual examination performed by the operator of the below-the-hook lifter conducted prior to and during every lift.

cont.

## Frequent Inspection:

Are comprised of visual inspections performed by either the lifter operator or other assigned personnel (records are not required by the ASME standard).

- Normal use – once a month
- Heavy use – once a week to once a monthly
- Severe use – once a day to once a week
- Special or infrequent use – outlined as specified by a qualified individual prior to and following each use.
- Any lifter that has been idle for a period of one month to a year shall undergo a frequent inspection prior to use.

The following items listed below shall be included within the regular inspection schedule and shall be thoroughly inspected and an assessment formed as to the extent of the issue and the level of subsequent hazard resulting from it.

- Structural deformation
- Cracks in welds or structural members
- Excessive wear
  - Loose or missing parts, tags, safety guards, fasteners, stops, and/or housings..
  - Out of adjustment conditions that interfere with the normal operation and functionality of all mechanisms including automatic hold and release components.
  - Contact Peerless Industrial Group for replacements of missing identification tags and nameplates.

## Periodic Inspections:

Are comprised of visual inspections performed by assigned personnel who record the current condition of the below-the-hook lifter in order to provide the basis for a continuing program of recorded evaluation. Dated reports for periodic inspections shall be maintained.

- Normal use – annual inspection typically performed on-site.
- Heavy use – disassembly by a qualified individual should be performed semi-annually in order to facilitate a detailed inspection.
- Severe use - disassembly by a qualified individual should be performed quarterly in order to facilitate a detailed inspection.
- Special or infrequent use – outlined as specified by a qualified individual prior to and following each use.
- Any lifter that has been idle for a period of one year or more shall undergo a periodic inspection prior to use.

Below-the-hook lifting devices shall undergo a thorough inspection based upon the previously defined intervals of every lift, frequent, and periodic. Any and all issues such as the following (as listed below) shall be investigated and a conclusion made as to if the extent of the issue and to if it is severe enough in its nature to represent a hazard. Dated inspection reports of the following critical items shall be made.

- All requirements outlined within the frequent inspection process.
- Missing or loose nuts, bolts, or fasteners.
- Fractured gears, pulleys, sheaves, sprockets, bearings, chain and belts.
- Excessive wear of linkages, gears, pulleys, sprockets, sheaves, chain, belts, bearings, hardware, and other mechanical parts.
- Excessive wear at the bail or other load bearing points.

All repairs or modifications shall be documented on dated inspection reports.

## MAINTENANCE:

### Preventive Maintenance:

A preventive maintenance program shall be established and be based on recommendations made by Peerless Industrial Group. It can be determined to be appropriate as designated by a qualified person to add to the maintenance program following a review of the use of the below-the-hook lifter.

Any hazards disclosed during an inspection shall be corrected before the lifting device is put back into service. Any repairs and/or adjustments shall be done only under the direction of or by a qualified person. Replacement parts shall be equivalent to the Peerless Industrial Group's specifications.

For more information or to purchase a copy of the standard, visit ASME website, [www.ASME.org](http://www.ASME.org).

# General Safety Guidelines

Peerless Industrial Group, as a manufacturer of chain, can only control the specifications of our chain products in accordance with industry and governmental standards for chain manufacturing. It would be impossible for any warning to contain all of the possible misapplication associated with the use of Peerless Industrial Group products. Our warnings are intended to identify only those risks which are most common. The responsibility and understanding of the proper safe use and application of the products in our catalog, ultimately rest with the end user. We are not responsible for the end user's assembly in which our products may be used. Failure of the product can occur due to misapplication, abuse, intentional alteration or improper maintenance. Product failure can result in property damage, personal injury or death.

## Working Load Limit (WLL)

The "Working Load Limit" (rated capacity) is the maximum load that shall be applied in direct tension to an undamaged straight length of chain, strap or fittings.

## Proof Test

The "Proof Test" (manufacturing test force) is a term designating the minimum tensile force which has been applied to a product under constantly increasing force in direct tension during the manufacturing process. These loads are manufacturing integrity tests and shall not be used as criteria for service or design purposes.

## Minimum Breaking Force

The "Minimum Breaking Force" is the minimum force at which the product during manufacture has been found by testing to break when a constantly increasing force is applied in direct tension. Breaking force values are not guarantees that all chain or strap segments will endure these loads. This test is a manufacturer's attribute acceptance test and shall not be used as a criteria for service or design purposes.

The Working Load Limits and the associated safety factor of each Peerless product may be affected by wear, misuse, overloading, corrosion, deformation, intentional alteration and other use conditions. Regular inspection must be conducted to determine whether use can be continued at the assigned Working Load Limit, a reduced Working Load Limit or whether the product must be withdrawn from service. The terms "Working Load Limit", "Proof

Test" and "Minimum Breaking Force" contain no implication of what load the product will withstand if the product is used in such conditions of abuse and misuse. Peerless Industrial Group accepts no liability for any such abuse or misuse.

The Working Load Limit of a sling or assembly must not exceed the lowest Working Load Limit of the components in the sling or assembly. Use only Peerless Industrial Group approved parts as replacements when servicing or repairing original Peerless Industrial Group slings or assemblies.

All Working Load Limits (WLL) shown in this catalog apply only to new or "in as new" condition products. USE ONLY GRADE 80 OR GRADE 100 ALLOY OR GRADE 50 STAINLESS STEEL CHAIN AND ATTACHMENTS FOR OVERHEAD LIFTING.

PEERLESS INDUSTRIAL GROUP PRODUCTS ARE INTENDED TO BE USED AT OR BELOW THE WORKING LOAD LIMITS (WLL) SPECIFIED IN CONSTANTLY INCREASING FORCE APPLICATIONS UNDER DIRECT TENSION OR IN A STRAIGHT LINE PULL.

SHOCK LOADING IS PROHIBITED AND SIDE LOADING MUST BE AVOIDED, AS IT EXERTS ADDITIONAL DYNAMIC FORCES OR LOADING WHICH THE PRODUCT IS NOT DESIGNED TO ACCOMMODATE.

THE CONDITIONS INVOLVING USE IN CERTAIN ENVIRONMENTAL SITUATIONS SUCH AS UNUSUAL (HIGH OR LOW) TEMPERATURE, CHEMICAL, ETC..., CAN CAUSE CHANGES IN CHAIN PERFORMANCE.

All chains and attachments in this catalog are capable of creating sparks unless otherwise noted.

Welding Peerless Industrial Group load support parts or products can be hazardous. Knowledge of materials, heat treatment and welding procedures are necessary for proper welding.

CONSULT PEERLESS INDUSTRIAL GROUP FOR ADDITIONAL INFORMATION OR QUESTIONS REGARDING THE USE AND APPLICATION OF THE PRODUCTS COVERED IN THIS CATALOG.

FOR MORE INFORMATION REGARDING THE SAFE USE OF OUR PRODUCTS, VISIT THE TECHNICAL INFO PAGE ON OUR WEBSITE.

## A

ADJUSTABLE BAIL LIFTING BEAM .....	19-21
ADJUSTABLE LIFTING BEAM .....	18
ADJUSTABLE FORK HEAVY DUTY PALLET LIFTER.....	76
ADJUSTABLE FORK HEAVY DUTY PALLET LIFTER (w/HAND WHEEL) .....	77
ADJUSTABLE FORK PALLET LIFTER .....	73
ADJUSTABLE FORK PALLET LIFTER (w/HAND WHEEL) .....	74
ADJUSTABLE TELESCOPIC SPREADER BEAM.....	34

## B

BAR TONG ADJUSTABLE .....	63
BAR TONG FIXED .....	62
BASKET SLING LIFTING BEAM .....	12-14
BOX SPREADER BEAM .....	35

## C

CHLORINE GAS CYLINDER LIFTING BEAM.....	29
COIL GRAB VERTICAL .....	56
COIL LIFTER .....	51
COIL LIFTERS .....	50-58
COIL GRAB VERTICAL .....	56
COIL LIFTER .....	51
COIL LIFTER NARROW COIL .....	50
COIL LIFTER CLOSE STACKING.....	52
COIL LIFTER SLIT COIL.....	53
COIL LIFTER TELESCOPIC TWO SIDED.....	57
COIL LIFTER VERTICAL.....	54
COIL LIFTER VERTICAL WIDE.....	55
NARROW ARM COIL LIFTER.....	58
COIL LIFTER NARROW COIL.....	50
COIL LIFTER CLOSE STACKING .....	52
COIL LIFTER SLIT COIL .....	53
COIL LIFTER TELESCOPIC TWO-SIDED .....	57
COIL LIFTER VERTICAL .....	54
COIL LIFTER VERTICAL WIDE .....	55
CUSTOM APPLICATION FORM.....	30, 42, 48, 59, 64, 69, 89, 91
COIL LIFTER.....	59
LIFTING BEAMS .....	30
MATERIAL BASKETS .....	91
MATERIAL STANDS .....	89
ROLL LIFTER .....	48
SHEET LIFTER .....	69
SPREADER BEAMS.....	42
TONG.....	64

## D

DUAL CRANE LIFTING BEAM .....	15-16
DUAL CRANE ROTATING BEAM.....	28

## E

END CAP.....	40
END CAP PIPE.....	40-41
END CAP SPREADER BEAM .....	36-39

## F

FIXED FORK HEAVY DUTY PALLET LIFTER.....	75
FIXED FORK PALLET LIFTER .....	72
FORK TRUCK ACCESSORIES .....	82-86
FORK TRUCK DOUBLE HOOK BEAM.....	86
FORK TRUCK HOOK .....	84
FORK TRUCK HOOK BEAM.....	85
TELESCOPIC FORK TRUCK BOOM.....	82
TELESCOPIC PIVOT FORK TRUCK BOOM.....	83
FORK TRUCK DOUBLE HOOK BEAM .....	86
FORK TRUCK HOOK .....	84
FORK TRUCK HOOK BEAM .....	85
FOUR POINT ADJUSTABLE BEAM.....	27
FOUR POINT LIFTING BEAM.....	25
FOUR POINT SACK LIFTING BEAM .....	26

## GHIJK

## L

LIFTING BEAMS.....	04-29
ADJUSTABLE BAIL LIFTING BEAM .....	19-21
ADJUSTABLE LIFTING BEAM .....	18
BASKET SLING LIFTING BEAM.....	12-14
CHLORINE GAS CYLINDER LIFTING BEAM .....	29
DUAL CRANE LIFTING BEAM.....	15-16
DUAL CRANE ROTATING BEAM .....	28
FOUR POINT ADJUSTABLE BEAM .....	27
FOUR POINT LIFTING BEAM .....	25
FOUR POINT SACK LIFTER BEAM .....	26
LOAD LEVELING BEAM .....	22-23
SHORT SPAN LIFTING BEAM.....	04-05
STANDARD DUTY LIFTING BEAM (CHANNEL DESIGN).....	06-08
STANDARD DUTY LIFTING BEAM (I-BEAM DESIGN w/ FLAME CUT BAIL).....	09-10
STANDARD DUTY LIFTING BEAM (I-BEAM DESIGN w/PIN BAIL).....	11
THREE POINT LIFTING BEAM.....	24
UNIVERSAL LIFTING/SPREADER BEAM.....	17
LIGHTWEIGHT PALLET LIFTER .....	79
LOAD LEVELING BEAM .....	22-23

## M

MATERIAL BASKETS HEAVY DUTY.....	90
MATERIAL HANDLING.....	88-90
MATERIAL BASKETS HEAVY DUTY .....	90
MATERIAL STANDS HEAVY DUTY .....	88
MATERIAL STANDS HEAVY DUTY.....	88
MOTORIZED ROLL LIFTER .....	45
MOTORIZED SHEET LIFTER HEAVY DUTY.....	67

## N

NARROW ARM COIL LIFTER .....	58
------------------------------	----

## O

## P

PALLET LIFTERS.....	72-79
ADJUSTABLE FORK HEAVY DUTY PALLET LIFTER.....	76
ADJUSTABLE FORK HEAVY DUTY PALLET LIFTER (w/HAND WHEEL).....	77
ADJUSTABLE FORK PALLET LIFTER .....	73
ADJUSTABLE FORK PALLET LIFTER (w/HAND WHEEL).....	74
FIXED FORK HEAVY DUTY PALLET LIFTER .....	75
FIXED FORK PALLET LIFTER .....	72
LIGHTWEIGHT PALLET LIFTER.....	79
WHEELED PALLET LIFTER .....	78

## Q

## R

ROLL LIFTERS .....	44-47
MOTORIZED ROLL LIFTER .....	45
ROLL GRIPPING TONGS .....	46
ROLL LIFTING BEAM .....	44
ROLL LIFTING C-HOOK .....	47
ROLL GRIPPING TONGS.....	46
ROLL LIFTING BEAM.....	44
ROLL LIFTING C-HOOK.....	47

## S

SAFETY GUIDELINES.....	92-95
SHEET LIFTERS .....	66-68
MOTORIZED SHEET LIFTER HEAVY DUTY .....	67
SHEET LIFTER HEAVY DUTY .....	66
SHEET LIFTER LIGHT DUTY.....	68
SHEET LIFTER HEAVY DUTY.....	66
SHEET LIFTER LIGHT DUTY .....	68
SHORT SPAN LIFTING BEAM .....	04-05
SPREADER BEAMS.....	31-41
ADJUSTABLE TELESCOPIC SPREADER BEAM .....	34
BOX SPREADER BEAM.....	35
END CAP SPREADER BEAM.....	36-41
STANDARD DUTY SPREADER BEAM .....	32-33
STANDARD DUTY LIFTING BEAM (CHANNEL DESIGN).....	06-08
STANDARD DUTY LIFTING BEAM (I-BEAM DESIGN w/FLAME CUT BAIL) .....	09-10
STANDARD DUTY LIFTING BEAM (I-BEAM DESIGN w/PIN BAIL) .....	11
STANDARD DUTY SPREADER BEAM .....	32-33

## T

TELESCOPIC FORK TRUCK BOOM.....	82
TELESCOPIC PIVOT FORK TRUCK BOOM .....	83
THREE POINT LIFTING BEAM.....	24
TONGS.....	62-63
BAR TONG ADJUSTABLE.....	62
BAR TONG FIXED.....	63

## U

UNIVERSAL LIFTING/SPREADER BEAM .....	17
---------------------------------------	----

## V

## W

WHEELED PALLET LIFTER .....	78
-----------------------------	----

## XYZ



# PART NUMBER INDEX

PART #	PAGE #								
ABLB-1/2-10	19	BSLB-1/2-14	12	CGV-7.5-24	56	DCLB-2-12	15	FCSB-120-36	39
ABLB-1/2-12	19	BSLB-1/2-16	12	CL-10-48	51	DCLB-2-14	15	FCSB-120-40	39
ABLB-1/2-14	19	BSLB-1/2-18	12	CL-10-60	51	DCLB-2-16	15	FCSB-120-8	39
ABLB-1/2-16	19	BSLB-1/2-20	12	CL-10-72	51	DCLB-2-18	15	FCSB-130-10	39
ABLB-1/2-18	19	BSLB-1/2-24	12	CL-15-48	51	DCLB-2-20	15	FCSB-130-12	39
ABLB-1/2-20	19	BSLB-1/2-3	12	CL-15-60	51	DCLB-2-24	15	FCSB-130-16	39
ABLB-1/2-3	19	BSLB-1/2-30	12	CL-15-72	51	DCLB-2-6	15	FCSB-130-20	39
ABLB-1/2-4	19	BSLB-1/2-4	12	CL-20-60	51	DCLB-2-8	15	FCSB-130-24	39
ABLB-1/2-6	19	BSLB-1/2-6	12	CL-20-72	51	DCLB-30-10	16	FCSB-130-28	39
ABLB-1/2-8	19	BSLB-1/2-8	12	CL-25-60	51	DCLB-30-12	16	FCSB-130-32	39
ABLB-10-10	21	BSLB-10-10	13	CL-25-72	51	DCLB-30-8	16	FCSB-130-36	39
ABLB-10-12	21	BSLB-10-12	13	CL-30-60	51	DCLB-40-10	16	FCSB-130-8	39
ABLB-10-14	21	BSLB-10-14	13	CL-30-72	51	DCLB-40-12	16	FCSB-15-10	37
ABLB-10-16	21	BSLB-10-16	13	CL-40-72	51	DCLB-40-8	16	FCSB-15-12	37
ABLB-10-18	21	BSLB-10-18	13	CL-50-84	51	DCLB-4-10	15	FCSB-15-16	37
ABLB-10-20	21	BSLB-10-20	13	CL-5-36	51	DCLB-4-12	15	FCSB-15-20	37
ABLB-10-3	21	BSLB-10-24	13	CL-5-48	51	DCLB-4-14	15	FCSB-15-24	37
ABLB-10-4	21	BSLB-10-3	13	CL-5-60	51	DCLB-4-16	15	FCSB-15-28	37
ABLB-10-6	21	BSLB-10-30	13	CL-7.5-36	51	DCLB-4-18	15	FCSB-15-32	37
ABLB-10-8	21	BSLB-10-4	13	CL-7.5-48	51	DCLB-4-20	15	FCSB-15-36	37
ABLB-1-10	19	BSLB-10-6	13	CL-7.5-60	51	DCLB-4-24	15	FCSB-15-40	37
ABLB-1-12	19	BSLB-10-8	13	CLCS-10-48	52	DCLB-4-6	15	FCSB-15-6	37
ABLB-1-14	19	BSLB-1-10	12	CLCS-10-60	52	DCLB-4-8	15	FCSB-15-8	37
ABLB-1-16	20	BSLB-1-12	12	CLCS-10-72	52	DCLB-6-10	15	FCSB-20-10	37
ABLB-1-18	20	BSLB-1-14	12	CLCS-15-48	52	DCLB-6-12	15	FCSB-20-12	37
ABLB-1-20	20	BSLB-1-16	12	CLCS-15-60	52	DCLB-6-14	15	FCSB-20-16	37
ABLB-1-3	19	BSLB-1-18	12	CLCS-15-72	52	DCLB-6-16	15	FCSB-20-20	37
ABLB-1-4	19	BSLB-1-20	12	CLCS-20-60	52	DCLB-6-18	15	FCSB-20-24	37
ABLB-15-10	21	BSLB-1-24	12	CLCS-20-72	52	DCLB-6-20	15	FCSB-20-28	37
ABLB-15-12	21	BSLB-1-3	12	CLCS-25-60	52	DCLB-6-24	15	FCSB-20-32	37
ABLB-15-14	21	BSLB-1-30	12	CLCS-25-72	52	DCLB-6-8	15	FCSB-20-36	37
ABLB-15-16	21	BSLB-1-4	12	CLCS-30-60	52	DCLB-6-8	15	FCSB-20-40	37
ABLB-15-18	21	BSLB-15-10	14	CLCS-30-72	52	FC-12-110	40	FCSB-20-6	37
ABLB-15-20	21	BSLB-15-12	14	CLCS-40-72	52	FC-12-130	40	FCSB-20-8	37
ABLB-15-3	21	BSLB-15-14	14	CLCS-5-36	52	FC-12-80	40	FCSB-25-10	37
ABLB-15-4	21	BSLB-15-16	14	CLCS-5-48	52	FC-5-25	40	FCSB-25-12	37
ABLB-15-6	21	BSLB-15-18	14	CLCS-5-60	52	FC-5-50	40	FCSB-25-16	37
ABLB-15-8	21	BSLB-15-20	14	CLCS-7.5-36	52	FC-8-50	40	FCSB-25-20	37
ABLB-1-6	19	BSLB-15-24	14	CLCS-7.5-48	52	FC-8-80	40	FCSB-25-24	37
ABLB-1-8	19	BSLB-15-30	14	CLCS-7.5-60	52	FCP-12-10	41	FCSB-25-28	37
ABLB-20-10	21	BSLB-15-4	14	CLNC-1/2-12	50	FCP-12-12	41	FCSB-25-32	37
ABLB-20-12	21	BSLB-15-6	14	CLNC-1/2-8	50	FCP-12-16	41	FCSB-25-36	37
ABLB-20-14	21	BSLB-15-8	14	CLNC-1-8	50	FCP-12-20	41	FCSB-25-40	37
ABLB-20-16	21	BSLB-1-6	12	CLNC-2-16	50	FCP-12-24	41	FCSB-25-6	37
ABLB-20-18	21	BSLB-1-8	12	CLNC-2-8	50	FCP-12-28	41	FCSB-25-8	37
ABLB-20-20	21	BSLB-20-10	14	CLNC-3-5-12	50	FCP-12-32	41	FCSB-30-10	37
ABLB-20-3	21	BSLB-20-12	14	CLNC-3-5-16	50	FCP-12-36	41	FCSB-30-12	37
ABLB-20-4	21	BSLB-20-14	14	CLNC-5-16	50	FCP-12-40	41	FCSB-30-16	37
ABLB-20-6	21	BSLB-20-16	14	CLSC-5-20	50	FCP-12-8	41	FCSB-30-20	37
ABLB-20-8	21	BSLB-20-18	14	CLSC-10-48	53	FCP-5-10	41	FCSB-30-24	37
ABLB-2-10	20	BSLB-20-20	14	CLSC-10-60	53	FCP-5-12	41	FCSB-30-28	37
ABLB-2-12	20	BSLB-20-24	14	CLSC-10-72	53	FCP-5-16	41	FCSB-30-32	37
ABLB-2-14	20	BSLB-20-3	14	CLSC-15-48	53	FCP-5-20	41	FCSB-30-36	37
ABLB-2-16	20	BSLB-20-30	14	CLSC-15-60	53	FCP-5-24	41	FCSB-30-40	37
ABLB-2-18	20	BSLB-20-4	14	CLSC-15-72	53	FCP-5-28	41	FCSB-30-6	37
ABLB-2-20	20	BSLB-20-6	14	CLSC-20-60	53	FCP-5-6	41	FCSB-30-8	37
ABLB-2-3	20	BSLB-20-8	14	CLSC-20-72	53	FCP-5-8	41	FCSB-40-10	37
ABLB-2-4	20	BSLB-2-10	13	CLSC-25-60	53	FCP-8-10	41	FCSB-40-12	37
ABLB-2-6	20	BSLB-2-12	13	CLSC-25-72	53	FCP-8-12	41	FCSB-40-16	37
ABLB-2-8	20	BSLB-2-14	13	CLSC-30-60	53	FCP-8-16	41	FCSB-40-20	37
ABLB-5-10	21	BSLB-2-16	13	CLSC-30-72	53	FCP-8-20	41	FCSB-40-24	37
ABLB-5-12	21	BSLB-2-18	13	CLSC-35-48	53	FCP-8-24	41	FCSB-40-28	37
ABLB-5-14	21	BSLB-2-20	13	CLSC-5-60	53	FCP-8-28	41	FCSB-40-32	37
ABLB-5-16	21	BSLB-2-24	13	CLSC-7.5-36	53	FCP-8-32	41	FCSB-40-36	37
ABLB-5-18	21	BSLB-2-30	13	CLSC-7.5-48	53	FCP-8-36	41	FCSB-40-40	37
ABLB-5-20	21	BSLB-2-3	13	CLSC-7.5-60	53	FCP-8-40	41	FCSB-40-6	37
ABLB-5-3	20	BSLB-2-4	13	CLT-10-48	57	FCP-8-8	41	FCSB-40-8	37
ABLB-5-4	20	BSLB-2-6	13	CLT-10-60	57	FCSB-100-10	39	FCSB-50-10	38
ABLB-5-6	20	BSLB-2-8	13	CLT-15-60	57	FCSB-100-12	39	FCSB-50-12	38
ALB-1-25-6	18	BSLB-5-10	13	CLT-15-72	57	FCSB-100-16	39	FCSB-50-16	38
ALB-2-6	18	BSLB-5-12	13	CLV-5-48	54	FCSB-100-20	39	FCSB-50-20	38
ALB-4-8	18	BSLB-5-14	13	CLV-5-60	54	FCSB-100-24	39	FCSB-50-24	38
ALB-5-10	18	BSLB-5-16	13	CLV-1-5-20	54	FCSB-100-28	39	FCSB-50-28	38
ATSB-10-12/20	34	BSLB-5-18	13	CLV-1/2-20	54	FCSB-100-32	39	FCSB-50-32	38
ATSB-10-4/6	34	BSLB-5-20	13	CLV-3-20	54	FCSB-100-36	39	FCSB-50-36	38
ATSB-10-6/10	34	BSLB-5-24	13	CLV-5-20	54	FCSB-100-40	39	FCSB-50-40	38
ATSB-10-8/14	34	BSLB-5-3	13	CLVW-1/2-24	55	FCSB-100-8	39	FCSB-50-6	38
ATSB-15-12/20	34	BSLB-5-4	13	CLVW-2-5-24	55	FCSB-10-10	36	FCSB-50-8	38
ATSB-15-4/6	34	BSLB-5-30	13	CLVW-5-24	55	FCSB-10-12	36	FCSB-5-10	36
ATSB-15-6/10	34	BSLB-5-4	13	CLVW-7.5-24	55	FCSB-10-16	36	FCSB-5-12	36
ATSB-15-8/14	34	BSLB-5-6	13	DCLB-10-10	16	FCSB-10-20	36	FCSB-5-16	36
ATSB-20-12/20	34	BSLB-5-8	13	DCLB-10-12	16	FCSB-10-24	36	FCSB-5-18	36
ATSB-20-7/11	34	BSLB-7-5-10	13	DCLB-10-14	16	FCSB-10-28	36	FCSB-5-20	36
ATSB-20-9/15	34	BSLB-7-5-12	13	DCLB-10-16	16	FCSB-10-32	36	FCSB-5-24	36
ATSB-2-12/20	34	BSLB-7-5-14	13	DCLB-10-18	16	FCSB-10-36	36	FCSB-5-28	36
ATSB-2-4/6	34	BSLB-7-5-16	13	DCLB-10-20	16	FCSB-10-40	36	FCSB-5-32	36
ATSB-25-12/20	34	BSLB-7-5-18	13	DCLB-10-24	16	FCSB-10-6	36	FCSB-5-36	36
ATSB-25-7/11	34	BSLB-7-5-20	13	DCLB-10-6	16	FCSB-10-8	36	FCSB-5-40	36
ATSB-25-9/15	34	BSLB-7-5-24	13	DCLB-10-8	16	FCSB-110-10	39	FCSB-5-6	36
ATSB-2-6/10	34	BSLB-7-5-3	13	DCLB-15-10	16	FCSB-110-12	39	FCSB-5-8	36
ATSB-2-8/14	34	BSLB-7-5-30	13	DCLB-15-12	16	FCSB-110-16	39	FCSB-60-10	38
ATSB-30-12/20	34	BSLB-7-5-4	13	DCLB-15-14	16	FCSB-110-20	39	FCSB-60-12	38
ATSB-30-7/11	34	BSLB-7-5-6	13	DCLB-15-16	16	FCSB-110-24	39	FCSB-60-16	38
ATSB-30-9/15	34	BSLB-7-5-8	13	DCLB-15-18	16	FCSB-110-28	39	FCSB-60-20	38
ATSB-40-12/20	34	BTA-1/2-2.5/4	63	DCLB-15-20	16	FCSB-110-32	39	FCSB-60-24	38
ATSB-40-7/11	34	BTA-1-10/15	63	DCLB-15-24	16	FCSB-110-36	39	FCSB-60-28	38
ATSB-40-9/15	34	BTA-1-15/20	63	DCLB-15-8	16	FCSB-110-40	39	FCSB-60-32	38
ATSB-5-12/20	34	BTA-1-4/7	63	DCLB-20-10	16	FCSB-110-8	39	FCSB-60-36	38
ATSB-5-4/6	34	BTF-1/2-5	62	DCLB-20-12	16	FCSB-120-10	39	FCSB-60-40	38
ATSB-5-6/10	34	BTF-1-8	62	DCLB-20-14	16	FCSB-120-12	39	FCSB-60-8	38
ATSB-5-8/14	34	CGCLB-2-80/82	26	DCLB-20-16	16	FCSB-120-16	39	FCSB-70-10	38
BSLB-1/2-10	12	CGV-10-24	56	DCLB-20-18	16	FCSB-120-20	39	FCSB-70-16	38
BSLB-1/2-12	12	CGV-2-5-24	56	DCLB-20-20	16	FCSB-120-24	39	FCSB-70-20	38
BSLB-1/2-14	12	CGV-5-24	56	DCLB-20-8	16	FCSB-120-28	39	FCSB-70-24	38
BSLB-1/2-16	12			DCLB-2-10	15	FCSB-120-32	39	FCSB-70-28	38

# PART NUMBER INDEX

ECSB-70-32	38	MSLHD-15-48	67	SDLB-1/2-14	6	SDLB-30-30	10	SDSB-2-8	32
ECSB-70-36	38	MSLHD-15-60	67	SDLB-1/2-16	6	SDLB-30-34	10	SDSB-30-10	33
ECSB-70-40	38	MSLHD-15-72	67	SDLB-1/2-18	6	SDLB-30-38	10	SDSB-30-12	33
ECSB-70-8	38	MSLHD-15-84	67	SDLB-1/2-20	6	SDLB-30-4	8	SDSB-30-16	33
ECSB-80-10	38	MSLHD-15-96	67	SDLB-1/2-24	6	SDLB-30-42	10	SDSB-30-20	33
ECSB-80-12	38	MSLHD-20-48	67	SDLB-1/2-3	6	SDLB-30-6	8	SDSB-30-6	33
ECSB-80-16	38	MSLHD-20-60	67	SDLB-1/2-30	6	SDLB-30-8	8	SDSB-30-8	33
ECSB-80-20	38	MSLHD-20-72	67	SDLB-1/2-4	6	SDLB-3-10	7	SDSB-40-10	33
ECSB-80-24	38	MSLHD-20-84	67	SDLB-1/2-6	6	SDLB-3-12	7	SDSB-40-12	33
ECSB-80-28	38	MSLHD-20-96	67	SDLB-1/2-8	6	SDLB-3-14	7	SDSB-40-16	33
ECSB-80-32	38	MSLHD-3-48	67	SDLB-1/2-10	6	SDLB-3-16	7	SDSB-40-6	33
ECSB-80-36	38	MSLHD-3-60	67	SDLB-10-12	7	SDLB-3-18	7	SDSB-40-8	33
ECSB-80-40	38	MSLHD-3-72	67	SDLB-10-14	7	SDLB-3-20	7	SDSB-5-10	32
ECSB-80-8	38	MSLHD-5-48	67	SDLB-10-16	7	SDLB-3-24	7	SDSB-5-12	32
ECSB-90-10	39	MSLHD-5-60	67	SDLB-10-18	7	SDLB-3-3	7	SDSB-5-16	32
ECSB-90-12	39	MSLHD-5-72	67	SDLB-10-20	10	SDLB-3-30	9	SDSB-5-20	32
ECSB-90-16	39	MSLHD-5-84	67	SDLB-10-24	10	SDLB-3-34	9	SDSB-5-24	32
ECSB-90-20	39	MSLHD-5-96	67	SDLB-10-3	7	SDLB-3-38	9	SDSB-5-4	32
ECSB-90-24	39	NACL-10-48	58	SDLB-10-30	10	SDLB-3-4	7	SDSB-5-6	32
ECSB-90-28	39	NACL-15-48	58	SDLB-10-34	10	SDLB-3-42	9	SDSB-5-8	32
ECSB-90-32	39	NACL-20-60	58	SDLB-10-38	10	SDLB-3-6	7	SLHD-10-48	66
ECSB-90-36	39	NACL-25-60	58	SDLB-10-4	7	SDLB-3-8	7	SLHD-10-60	66
ECSB-90-40	39	NACL-30-72	58	SDLB-10-42	10	SDLB-40-10	10	SLHD-10-72	66
ECSB-90-8	39	PL-1-5-36	72	SDLB-10-6	7	SDLB-40-12	10	SLHD-10-84	66
FH-1-5-4-5	84	PL-1-5-42	72	SDLB-10-8	6	SDLB-40-14	10	SLHD-10-96	66
FH-1-5-5-5	84	PL-1-5-48	72	SDLB-1-10	6	SDLB-40-16	10	SLHD-15-48	66
FH-1-5-6-5	84	PL-1-36	72	SDLB-1-12	6	SDLB-40-18	10	SLHD-15-60	66
FHB-10-36	85	PL-1-42	72	SDLB-1-14	6	SDLB-40-20	10	SLHD-15-72	66
FHB-15-36	85	PL-1-48	72	SDLB-1-16	6	SDLB-40-24	10	SLHD-15-84	66
FHB-2-20	85	PL-2-36	72	SDLB-1-18	6	SDLB-40-30	10	SLHD-15-96	66
FHB-5-24	85	PL-2-42	72	SDLB-1-20	6	SDLB-40-34	10	SLHD-20-48	66
FHB-5-36	85	PL-2-48	72	SDLB-1-24	6	SDLB-40-38	10	SLHD-20-60	66
FHB-7-5-36	85	PL-3-42	72	SDLB-1-3	6	SDLB-40-4	10	SLHD-20-72	66
FHBD-2-20	86	PL-3-48	72	SDLB-1-30	9	SDLB-40-42	10	SLHD-20-84	66
FHBD-5-24	86	PL-3-54	72	SDLB-1-34	9	SDLB-40-6	8	SLHD-20-96	66
FHBS-10-36	85	PL-4-48	72	SDLB-1-38	9	SDLB-40-8	10	SLHD-3-48	66
FHBS-15-36	85	PL-4-60	72	SDLB-1-4	6	SDLB-50-10	11	SLHD-3-60	66
FHBS-2-20	85	PL-5-48	72	SDLB-1-42	9	SDLB-50-15	11	SLHD-3-72	66
FHBS-5-24	85	PL-5-60	72	SDLB-15-10	8	SDLB-50-20	11	SLHD-5-48	66
FHBS-5-36	85	PLAF-1-5-36	73	SDLB-15-12	8	SDLB-5-10	7	SLHD-5-60	66
FHBS-7-5-36	85	PLAF-1-5-42	73	SDLB-15-14	8	SDLB-5-12	7	SLHD-5-72	66
FHS-1-5-4-5	84	PLAF-1-5-48	73	SDLB-15-16	8	SDLB-5-14	7	SLHD-5-84	66
FHS-1-5-5-5	84	PLAF-1-36	73	SDLB-15-18	8	SDLB-5-16	7	SLHD-5-96	66
FHS-1-5-6-5	84	PLAF-1-42	73	SDLB-15-20	8	SDLB-5-18	7	SLLD-1-5-36	68
FPAB-10-144/96	27	PLAF-1-48	73	SDLB-15-24	10	SDLB-5-20	7	SLLD-1-5-48	68
FPAB-3-84/60	27	PLAF-1-48	73	SDLB-15-3	8	SDLB-5-24	7	SLLD-3-48	68
FPAB-5-120/96	27	PLAF-2-42	73	SDLB-15-30	10	SDLB-5-3	7	SLLD-3-60	68
FPSL-1-365K	26	PLAF-2-48	73	SDLB-15-34	10	SDLB-5-30	9	SLLD-5-48	68
FPSL-1-485K	26	PLAF-3-42	73	SDLB-15-38	10	SDLB-5-34	9	SLLD-5-60	68
FPSL-2-365K	26	PLAF-3-48	73	SDLB-15-4	8	SDLB-5-38	9	SSLB-25-1	5
FPSL-2-485K	26	PLAF-3-54	73	SDLB-15-42	10	SDLB-5-4	7	SSLB-25-2	5
LLB-10-10	22	PLAF-4-48	73	SDLB-15-6	8	SDLB-5-42	9	SSLB-25-3	5
LLB-10-12	22	PLAF-4-60	73	SDLB-15-8	8	SDLB-5-6	7	SSLB-10-2	5
LLB-10-14	23	PLAF-5-48	73	SDLB-1-6	6	SDLB-5-8	7	SSLB-10-3	5
LLB-10-16	23	PLAF-5-60	73	SDLB-1-8	6	SDLB-65-10	11	SSLB-1-1	5
LLB-10-18	23	PLAH-10-48	77	SDLB-20-10	8	SDLB-65-15	11	SSLB-110-2	5
LLB-10-20	23	PLAH-10-60	77	SDLB-20-12	8	SDLB-65-20	11	SSLB-110-3	5
LLB-10-24	23	PLAH-10-72	77	SDLB-20-14	10	SDLB-7-5-10	7	SSLB-1-2	5
LLB-10-4	22	PLAH-12-5-48	77	SDLB-20-16	10	SDLB-7-5-12	7	SSLB-1-3	5
LLB-10-6	22	PLAH-12-5-60	77	SDLB-20-18	10	SDLB-7-5-14	7	SSLB-149-2	5
LLB-10-8	22	PLAH-12-5-72	77	SDLB-20-20	10	SDLB-7-5-16	7	SSLB-149-3	5
LLB-15-10	23	PLAH-15-60	77	SDLB-20-24	10	SDLB-7-5-18	7	SSLB-170-2	5
LLB-15-12	23	PLAH-15-72	77	SDLB-20-3	8	SDLB-7-5-20	9	SSLB-170-3	5
LLB-15-14	23	PLAH-7-5-48	77	SDLB-20-30	10	SDLB-7-5-24	9	SSLB-195-2	5
LLB-15-16	23	PLAH-7-5-60	77	SDLB-20-34	10	SDLB-7-5-3	7	SSLB-195-3	5
LLB-15-18	23	PLAH-7-5-72	77	SDLB-20-38	10	SDLB-7-5-30	9	SSLB-20-2	5
LLB-15-20	23	PLHA-10-48	76	SDLB-20-4	8	SDLB-7-5-34	9	SSLB-20-3	5
LLB-15-24	23	PLHA-10-60	76	SDLB-20-42	10	SDLB-7-5-38	9	SSLB-3-1	5
LLB-15-4	23	PLHA-10-72	76	SDLB-20-6	8	SDLB-7-5-4	7	SSLB-3-2	5
LLB-15-6	23	PLHA-12-5-48	76	SDLB-20-8	8	SDLB-7-5-42	9	SSLB-3-3	5
LLB-15-8	23	PLHA-12-5-60	76	SDLB-2-10	7	SDLB-7-5-6	7	SSLB-40-2	5
LLB-20-10	23	PLHA-12-5-72	76	SDLB-2-12	7	SDLB-7-5-8	7	SSLB-40-3	5
LLB-20-12	23	PLHA-7-5-48	76	SDLB-2-14	7	SDLB-80-10	11	SSLB-50-2	5
LLB-20-14	23	PLHA-7-5-60	76	SDLB-2-16	7	SDLB-80-15	11	SSLB-50-3	5
LLB-20-16	23	PLHA-7-5-72	76	SDLB-2-18	7	SDLB-80-20	11	SSLB-70-2	5
LLB-20-18	23	PLHD-10-48	75	SDLB-2-20	7	SDSB-10-10	32	SSLB-70-3	5
LLB-20-20	23	PLHD-10-60	75	SDLB-2-24	7	SDSB-10-12	32	TB-30	82
LLB-20-24	23	PLHD-15-48	75	SDLB-2-3	7	SDSB-10-16	32	TB-40	82
LLB-20-4	23	PLHD-15-60	75	SDLB-2-30	9	SDSB-10-20	32	TB-60	82
LLB-20-6	23	PLHD-20-60	75	SDLB-2-34	9	SDSB-10-24	32	TB-80	82
LLB-20-8	23	PLHD-20-72	75	SDLB-2-38	9	SDSB-10-4	32	TBP-30	83
LLB-2-10	22	PLHD-7-5-48	75	SDLB-2-4	7	SDSB-10-6	32	TBP-40	83
LLB-2-12	22	PLHD-7-5-60	75	SDLB-2-42	9	SDSB-10-8	32	TBP-60	83
LLB-2-14	22	PLHW-1-5-36	74	SDLB-25-10	8	SDSB-15-10	33	TBP-80	83
LLB-2-16	22	PLHW-1-5-42	74	SDLB-25-12	8	SDSB-15-12	33	UNVB-1/2-10	17
LLB-2-18	22	PLHW-1-5-48	74	SDLB-25-14	10	SDSB-15-16	33	UNVB-1/2-4	17
LLB-2-20	22	PLHW-1-36	74	SDLB-25-16	10	SDSB-15-20	33	UNVB-1/2-6	17
LLB-2-24	22	PLHW-1-42	74	SDLB-25-18	10	SDSB-15-24	33	UNVB-1/2-8	17
LLB-2-4	22	PLHW-1-48	74	SDLB-25-20	10	SDSB-15-4	32	UNVB-1/4-4	17
LLB-2-6	22	PLHW-2-36	74	SDLB-25-24	10	SDSB-15-6	32	UNVB-1-10	17
LLB-2-8	22	PLHW-2-42	74	SDLB-25-30	10	SDSB-15-8	32	UNVB-1-6	17
LLB-5-10	22	PLHW-2-48	74	SDLB-25-34	10	SDSB-20-10	33	UNVB-1-8	17
LLB-5-12	22	PLHW-3-42	74	SDLB-25-38	10	SDSB-20-12	33	UNVB-2-10	17
LLB-5-14	22	PLHW-3-48	74	SDLB-25-4	8	SDSB-20-16	33	UNVB-2-6	17
LLB-5-16	22	PLHW-3-54	74	SDLB-25-42	10	SDSB-20-20	33	UNVB-2-8	17
LLB-5-18	22	PLHW-4-48	74	SDLB-25-6	8	SDSB-20-24	33	UNVB-4-10	17
LLB-5-20	22	PLHW-4-60	74	SDLB-25-8	8	SDSB-20-4	33	UNVB-4-12	17
LLB-5-24	22	PLHW-5-48	74	SDLB-2-6	7	SDSB-20-6	33	UNVB-4-8	17
LLB-5-4	22	PLHW-5-60	74	SDLB-2-8	7	SDSB-20-8	33	UNVB-5-10	17
LLB-5-6	22	PLLW-1-48	79	SDLB-30-10	10	SDSB-2-10	32	UNVB-5-12	17
LLB-5-8	22	PLLW-2-48	79	SDLB-30-12	10	SDSB-2-12	32	UNVB-5-8	17
MSLHD-10-48	67	PLLW-3-48	79	SDLB-30-14	10	SDSB-2-16	32	UNVB-7-12	17
MSLHD-10-60	67	PLWL-1-48	78	SDLB-30-16	10	SDSB-2-20	32		
MSLHD-10-72	67	PLWL-2-48	78	SDLB-30-18	10	SDSB-2-24	32		
MSLHD-10-84	67	SDLB-1/2-10	6	SDLB-30-20	10	SDSB-2-4	32		
MSLHD-10-96	67	SDLB-1/2-12	6	SDLB-30-24	10	SDSB-2-6	32		



**Headquarters:**  
Winona, Minnesota  
PH: 800-873-1916 | FAX: 800-356-1149

**Custom Lifting Device  
Manufacturing:**  
Mount Pleasant, Pennsylvania  
PH: 800-395-2445 | FAX: 800-997-3192  
South Holland, Illinois  
PH: 800-334-5643 | FAX: 800-334-5643

**Distribution Centers:**  
Clackamas, Oregon  
PH: 800-547-6806 | FAX: 800-468-4430  
Reno, Nevada  
Elizabethtown, Pennsylvania  
Dallas, Texas  
Necedah, Wisconsin

**Warranty:**

The goods sold in this catalog are warranted free from defects in workmanship and materials for 12 months from the ship date.

**Disclaimer of warranties:**

No other warranty, express or implied, including the implied warranty of merchantability or fitness for particular purpose, is given and no affirmation of Peerless Industrial Group, by words or action, shall constitute a warranty. Peerless Industrial Group will not pay any claim for labor on any of its products or for delays or damages by reason on their use.

**Buyer's Remedies:**

Buyer's sole remedy for breach of any warranty is limited exclusively to obtaining, at the discretion of Peerless Industrial Group, either repair or replacement of any product sold hereunder and manufactured by Peerless Industrial Group. In no event shall Peerless Industrial Group be liable for any incidental or consequential damages. Buyer must notify Peerless Industrial Group, in writing, within 10 days of discovery of the alleged defect, if within the warranty period stated above. After receiving authorization from Peerless Industrial Group, product shall be returned to the Peerless Industrial Group plant, transportation prepaid, within 30 days.

**Return Goods Policy:** Items purchased from this catalog are returnable **ONLY** when pre-authorized by a Peerless Industrial Group Customer Service Representative, who will issue a Return Authorization Number. This number must be displayed **PROMINENTLY** on the return material shipping containers **AND** the carrier's freight bill. **UNAUTHORIZED SHIPMENTS WILL BE REFUSED AND RETURNED AT THE SENDER'S EXPENSE.** All authorized returns must be sent prepaid to Winona, MN, South Holland, IL, Jeannette, PA, or Clackamas OR, and are subject to restocking and repackaging charges. Any product not returned in original saleable condition will be subject to an additional reconditioning charge.

**Claims and Shortages:** Peerless is willing to assist you in collecting claims for lost or damaged goods, however we are not responsible for collection of claims or replacement of merchandise. All requests for assistance must be accompanied by a copy of the freight bill noting the shortage or damage and signed by the delivering carrier's driver. All requests made to Peerless Industrial Group must be received within 30 days of date of delivery.

**Minimum Invoice:** The minimum invoice allowed is \$100. A \$10 charge will be applied to any invoice below this amount.



# PEERLESS INDUSTRIAL GROUP Inc.

## Your Link to Quality, Strength & Service Since 1917

Established in 1917, Peerless Chain Company began as a small automotive tire chain manufacturer supplying local garage owners and has since evolved into the Peerless Industrial Group. Today, Peerless is the market leader in the design, manufacturing and supply of chain, overhead lifting, cargo control and traction products in North America.

Headquartered in Winona, Minnesota, Peerless operates three manufacturing locations and six distribution centers. The company offers best-in-class products, innovation and custom solutions to a diverse industrial and consumer customer base. The Peerless product offering is grouped into six categories: overhead lifting, below-the-hook and material handling, cargo control, hardware and industrial, marine and traction. Peerless is recognized around the world for the premium product brands of ACCO, Peerless, SCC and the patented products provided within each brand.

In August of 2014, Peerless became a wholly owned subsidiary and manufacturing site of KITO Corporation, which is the largest producer of chain and wire rope hoists in the world. The combination of Peerless, Harrington and KITO brands gives our combined customers access to a much wider variety of products in the markets we serve throughout KITO's global network.



[www.peerlesschain.com](http://www.peerlesschain.com)

**Our website features detailed product specifications, safety guidelines, component references and additional information in a downloadable format. Conveniently search by keywords or item number to learn more about a specific product to determine your exact needs. Information is neatly organized in categories to save you time when searching.**

Learn more about our company and products; download current literature and much more!

